

protocol for amidation of 4-aminocyclohexanecarboxylic acid

Author: BenchChem Technical Support Team. **Date:** May 2026

Compound of Interest

Compound Name: 4-Aminocyclohexane-1-carboxamide hydrochloride

CAS No.: 856563-23-0

Cat. No.: B1523020

[Get Quote](#)

An In-Depth Guide to the Amidation of 4-Aminocyclohexanecarboxylic Acid: Protocols and Mechanistic Insights

Introduction

4-Aminocyclohexanecarboxylic acid (ACCA) is a pivotal building block in modern drug discovery and development. Its rigid, saturated carbocyclic scaffold serves as a versatile bioisostere for aromatic rings, enabling chemists to fine-tune physicochemical properties such as solubility, metabolic stability, and lipophilicity. The trans-isomer, in particular, offers a well-defined spatial arrangement of its amino and carboxylic acid functionalities, making it an ideal scaffold for constructing constrained analogues of peptides and other bioactive molecules.^{[1][2]} The formation of an amide bond by derivatizing its carboxylic acid moiety is one of the most fundamental and frequently employed transformations in medicinal chemistry.^{[3][4]}

This application note provides a comprehensive guide for researchers, scientists, and drug development professionals on the successful amidation of 4-aminocyclohexanecarboxylic acid. It moves beyond simple step-by-step instructions to explain the underlying chemical principles,

the rationale behind reagent selection, and strategies for overcoming common challenges. We will detail two robust, field-proven protocols utilizing common coupling reagents and provide the necessary mechanistic context to empower users to adapt and troubleshoot these reactions effectively.

Part 1: Foundational Principles and Pre-Reaction Strategy

The direct coupling of a carboxylic acid and an amine is kinetically slow and requires the "activation" of the carboxylic acid to proceed at a reasonable rate.^[5] This is because the hydroxyl group of the carboxylic acid is a poor leaving group. Coupling reagents transform the hydroxyl into a better leaving group, making the carboxyl carbon highly electrophilic and susceptible to nucleophilic attack by an amine.

However, 4-aminocyclohexanecarboxylic acid is a bifunctional molecule. Attempting a direct coupling with an external amine without prior modification will lead to competitive self-polymerization, significantly reducing the yield of the desired product. Therefore, a protecting group strategy is not just recommended; it is essential.

The Critical Role of N-Protection

To ensure selective amidation at the carboxylic acid, the nucleophilicity of the amino group must be temporarily masked. The tert-butyloxycarbonyl (Boc) group is an ideal choice for this purpose due to its ease of installation, stability to a wide range of reaction conditions (including the basic conditions often used in coupling reactions), and straightforward removal under acidic conditions.^{[6][7]}

Protocol: N-Boc Protection of trans-4-Aminocyclohexanecarboxylic Acid

This protocol details the synthesis of trans-4-(tert-butoxycarbonylamino)cyclohexane-1-carboxylic acid, the key starting material for subsequent amidation reactions.^[8]

Materials:

- trans-4-Aminocyclohexanecarboxylic acid (1.0 equiv)

- Dioxane
- Water
- Sodium hydroxide (NaOH) (2.5 equiv)
- Di-tert-butyl dicarbonate (Boc)₂O (1.1 equiv)
- 1 M Hydrochloric acid (HCl)
- Ethyl acetate (EtOAc)

Procedure:

- Suspend trans-4-aminocyclohexanecarboxylic acid in a 1:1 mixture of dioxane and water.
- Cool the suspension to 0 °C in an ice bath.
- Add a solution of sodium hydroxide in water dropwise, ensuring the temperature remains below 10 °C.
- Add di-tert-butyl dicarbonate, either neat or as a solution in dioxane.
- Allow the reaction to warm to room temperature and stir overnight.
- Monitor the reaction by TLC or LC-MS until the starting material is consumed.
- Once complete, concentrate the mixture under reduced pressure to remove the dioxane.
- Cool the remaining aqueous solution to 0 °C and acidify to pH 2-3 with 1 M HCl. A white precipitate should form.
- Extract the product into ethyl acetate (3x).
- Wash the combined organic layers with brine, dry over anhydrous sodium sulfate (Na₂SO₄), filter, and concentrate in vacuo to yield the N-Boc protected acid, typically as a white solid.

Part 2: Core Amidation Methodologies and Protocols

With the N-protected ACCA in hand, the carboxylic acid can be activated and coupled with a desired amine. We present two widely used, reliable methods: one based on a carbodiimide reagent (EDC) and the other on a uronium salt (HATU).

Method 1: EDC/HOBt-Mediated Amide Coupling

This is a classic, cost-effective, and highly reliable method for amide bond formation.^{[3][9]}

- Principle of Operation: 1-Ethyl-3-(3-dimethylaminopropyl)carbodiimide (EDC) is a water-soluble carbodiimide that reacts with the carboxylic acid to form a highly reactive O-acylisourea intermediate.^{[5][10][11]} This intermediate is prone to rearranging into an unreactive N-acylurea byproduct.^[12] To mitigate this and reduce potential racemization, an additive like N-hydroxybenzotriazole (HOBt) is used. HOBt intercepts the O-acylisourea to form an HOBt-ester, which is more stable and reacts cleanly with the amine to form the desired amide.^{[5][12]} A non-nucleophilic base, such as N,N-diisopropylethylamine (DIPEA), is added to neutralize any acid salts and facilitate the reaction.

The reaction proceeds through a two-step activation and coupling pathway.

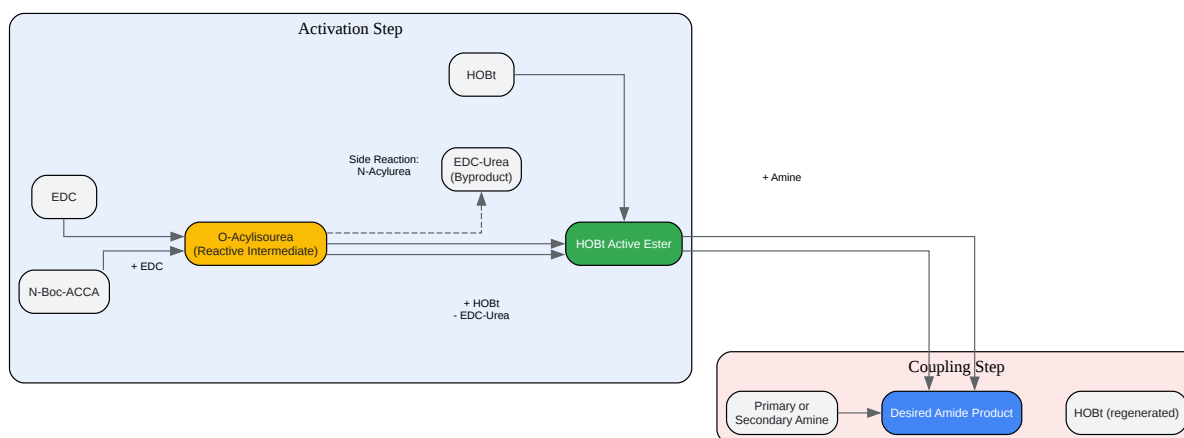

[Click to download full resolution via product page](#)

Mechanism of EDC/HOBt-mediated amidation.

Materials:

- trans-N-Boc-ACCA (1.0 equiv)
- Amine (primary or secondary) (1.1 - 1.2 equiv)
- EDC·HCl (1.2 - 1.5 equiv)
- HOBt (1.2 - 1.5 equiv)
- DIPEA (2.0 - 3.0 equiv)

- Anhydrous N,N-Dimethylformamide (DMF) or Dichloromethane (DCM)

Procedure:

- To a round-bottom flask under an inert atmosphere (N₂ or Ar), add trans-N-Boc-ACCA (1.0 equiv), HOBt (1.2 equiv), and the desired amine (1.1 equiv).[5]
- Dissolve the mixture in anhydrous DMF or DCM (to a concentration of ~0.1-0.5 M).
- Cool the solution to 0 °C in an ice bath with magnetic stirring.
- Add EDC·HCl (1.2 equiv) portion-wise to the reaction mixture.
- Add DIPEA (2.5 equiv) dropwise. The mixture may become thicker.
- Allow the reaction to slowly warm to room temperature and stir for 4-18 hours.
- Monitor the reaction progress by TLC or LC-MS.
- Workup: Upon completion, dilute the reaction mixture with an organic solvent like ethyl acetate. Wash successively with 5% aqueous citric acid, saturated aqueous sodium bicarbonate (NaHCO₃), and brine.[9] The aqueous washes remove the water-soluble urea byproduct and excess reagents.[9]
- Purification: Dry the organic layer over anhydrous Na₂SO₄, filter, and concentrate under reduced pressure. Purify the crude product by flash column chromatography on silica gel to yield the pure amide.[5]

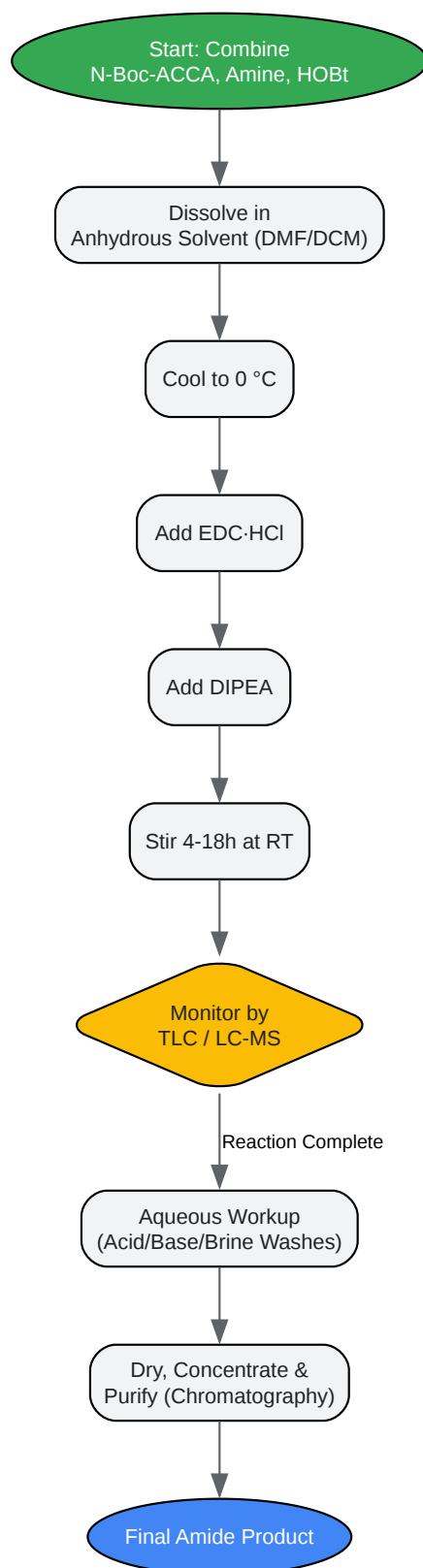

[Click to download full resolution via product page](#)

Workflow for EDC/HOBt mediated amidation.

Method 2: HATU-Mediated Amide Coupling

HATU is a third-generation uronium/aminium-type coupling reagent known for its high efficiency, fast reaction rates, and ability to couple even sterically hindered substrates with minimal racemization.[13][14][15] It is often the reagent of choice when EDC/HOBt fails or is too slow.

- Principle of Operation: In the presence of a base like DIPEA, the carboxylic acid is deprotonated. The resulting carboxylate attacks HATU to form a highly reactive OAt-active ester, releasing tetramethylurea.[5][15][16] The pyridine nitrogen in the HOAt leaving group is thought to facilitate the subsequent nucleophilic attack by the amine via a favorable transition state, accelerating the reaction.[15]

The HATU mechanism involves rapid formation of a potent activated ester.

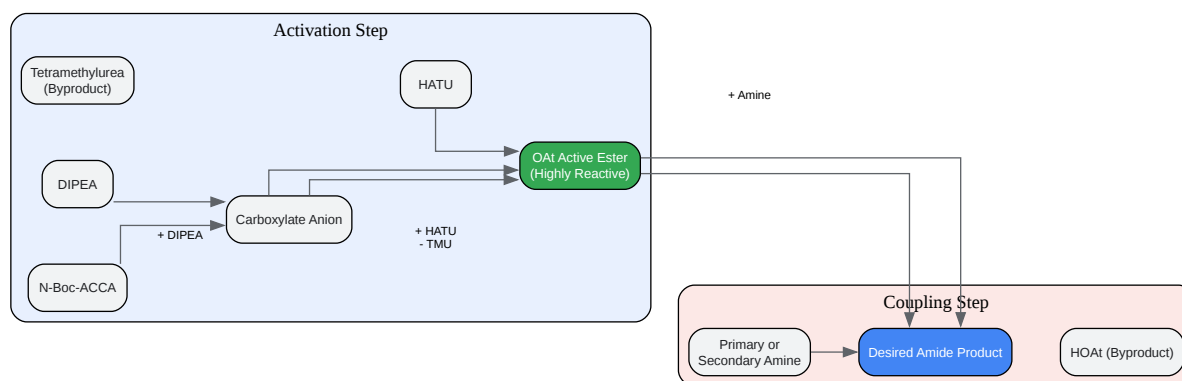

[Click to download full resolution via product page](#)

Mechanism of HATU-mediated amidation.

Materials:

- trans-N-Boc-ACCA (1.0 equiv)
- HATU (1.1 - 1.2 equiv)
- Amine (primary or secondary) (1.1 - 1.2 equiv)
- DIPEA (3.0 equiv)
- Anhydrous N,N-Dimethylformamide (DMF)

Procedure:

- In a round-bottom flask under an inert atmosphere, combine trans-N-Boc-ACCA (1.0 equiv) and HATU (1.1 equiv).
- Add anhydrous DMF to dissolve the solids (concentration typically 0.1-0.5 M).
- Cool the solution to 0 °C using an ice bath.
- Add DIPEA (3.0 equiv) dropwise to the stirred solution.
- Allow the mixture to stir at 0 °C for 15-30 minutes for pre-activation.^[5]
- Add the amine (1.1 equiv), either neat or as a solution in a small amount of anhydrous DMF.
- Allow the reaction to warm to room temperature and stir for 1 to 4 hours. HATU reactions are typically much faster than EDC couplings.
- Monitor the reaction progress by TLC or LC-MS.
- Workup: Upon completion, dilute the reaction mixture with ethyl acetate and wash with water or brine to remove DMF and byproducts. The workup is often simpler than for EDC reactions.
- Purification: Dry the organic layer over anhydrous Na₂SO₄, filter, and concentrate in vacuo. Purify the crude product by flash column chromatography.

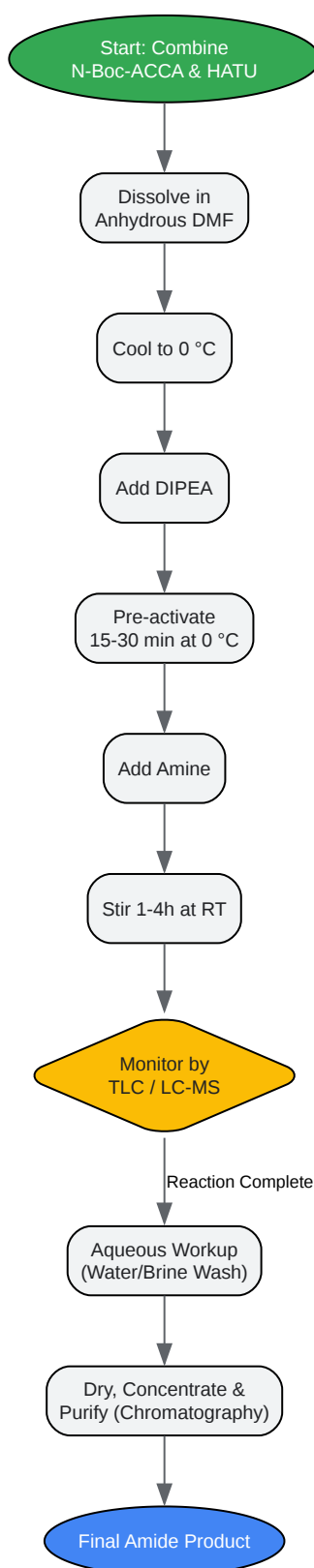

[Click to download full resolution via product page](#)

Workflow for HATU mediated amidation.

Part 3: Data Summary and Troubleshooting

Comparison of Coupling Reagents

Feature	EDC / HOBT	HATU
Activation Method	Carbodiimide	Uronium / Aminium Salt
Reaction Speed	Moderate to Slow (4-18 h)	Fast (1-4 h)
Efficiency	Good for most substrates	Excellent, especially for hindered amines
Byproducts	Water-soluble urea, HOBT	Water-soluble urea, HOAt
Cost	Lower	Higher
Side Reactions	N-acylurea formation (minimized by HOBT)	Minimal
Racemization	Low with HOBT additive	Very low

Troubleshooting Guide

Problem	Potential Cause(s)	Suggested Solution(s)
Low or No Yield	1. Inactive reagents (moisture contamination). 2. Insufficient activation time. 3. Poorly nucleophilic amine.	1. Use fresh, anhydrous solvents and reagents. 2. For HATU, ensure pre-activation step is performed. 3. Switch to a more powerful coupling reagent like HATU.
Incomplete Reaction	1. Insufficient equivalents of coupling reagent or base. 2. Steric hindrance.	1. Increase equivalents of coupling reagents and base to 1.5 and 3.0, respectively. 2. Increase reaction time and/or temperature (e.g., to 40 °C).
Formation of N-Acylurea	(EDC Protocol) The O-acylisourea intermediate rearranged before reacting with the amine or HOBT. [12] [17]	Ensure HOBT is added with the starting materials before EDC. Check the purity of EDC.
Difficulty in Purification	Byproducts (urea, HOAt) co-elute with the product.	Perform a thorough aqueous workup. For EDC, acidic and basic washes are crucial for removing the urea byproduct. [9]

Part 4: Post-Coupling Deprotection

If the final desired compound requires a free primary amine, the Boc group can be easily removed.

Protocol: Boc Deprotection

- Dissolve the N-Boc protected amide in a suitable solvent such as Dichloromethane (DCM) or Dioxane.
- Add an excess of a strong acid. A 20-50% solution of Trifluoroacetic Acid (TFA) in DCM is common. Alternatively, 4 M HCl in dioxane can be used.

- Stir the reaction at room temperature for 1-2 hours.
- Monitor the reaction by TLC or LC-MS.
- Upon completion, concentrate the reaction mixture in vacuo to remove the acid and solvent. The product is typically obtained as its corresponding salt (e.g., TFA or HCl salt).
- The salt can be used directly or neutralized with a base and purified further if necessary.

Conclusion

The amidation of 4-aminocyclohexanecarboxylic acid is a cornerstone transformation for generating valuable molecular scaffolds in pharmaceutical research. Success hinges on a logical strategy that begins with the crucial step of N-protection to prevent unwanted side reactions. By employing robust coupling protocols, such as the cost-effective EDC/HOBt method or the highly efficient HATU-based approach, researchers can reliably synthesize a diverse array of amide derivatives. Understanding the mechanisms behind these reagents, as detailed in this guide, allows for intelligent troubleshooting and optimization, ultimately accelerating the drug discovery process.

References

- Benchchem. (n.d.). Application Notes and Protocols for Amide Bond Formation using EDC and HATU. Benchchem.
- Suzhou Highfine Biotech. (2025, April 24). HATU: The Core Reagent for Peptide & Drug Synthesis. Suzhou Highfine Biotech.
- Wikipedia. (n.d.). Carbodiimide. Wikipedia.
- Park, K., et al. (2001). Mechanism of amide formation by carbodiimide for bioconjugation in aqueous media. PubMed.
- Common Organic Chemistry. (n.d.). Amine to Amide Mechanism - HATU. Common Organic Chemistry.
- Pottorf, R. S., et al. (n.d.). Synthesis of amide derivatives for electron deficient amines and functionalized carboxylic acids using EDC and DMAP and a catalytic amount of HOBt as the coupling reagents. PMC.
- ChemicalBook. (2024, July 3). HATU : a third-generation coupling reagent. ChemicalBook.
- Wikipedia. (n.d.). HATU. Wikipedia.
- Organic Synthesis. (n.d.). Acid-Amine Coupling using EDCI. Organic Synthesis.
- Aapptec Peptides. (2021, May 19). Carbodiimides and Additives. Aapptec Peptides.

- Common Organic Chemistry. (n.d.). Amine to Amide (EDC + HOBt). Common Organic Chemistry.
- Chemistry Steps. (2025, November 29). Amides from Carboxylic Acids-DCC and EDC Coupling. Chemistry Steps.
- Aapptec Peptides. (n.d.). Standard Coupling Procedures; DIC/HOBt; PyBOP; HBTU; PyBrOP. Aapptec Peptides.
- Taylor & Francis. (n.d.). Carbodiimide – Knowledge and References. Taylor & Francis.
- Siegfried AG. (2021, January 26). Process for preparing trans-4-amino-1-cyclohexanecarboxylic acids and derivatives thereof (CN108602758B). Google Patents.
- PrepChem.com. (n.d.). Preparation of 4-aminocyclohexanecarboxylic acid. PrepChem.com.
- SynArchive. (n.d.). Protecting Groups List. SynArchive.
- Shionogi & Co., Ltd. (2003, September 25). PROCESS FOR PREPARATION OF trans-4-AMINOCYCLOHEXANE- CARBOXYLIC ACIDS (WO2003078381A1). Google Patents.
- ResearchGate. (n.d.). Short and Efficient Process for the Synthesis of trans- 4- Aminocyclohexanecarboxylic Acid Derivatives | Request PDF. ResearchGate.
- Emcure Pharmaceuticals Limited. (n.d.). A Method Of Preparing Trans 4 Amino 1 Cyclohexane Carboxylic Acid Derivatives.
- HepatoChem. (n.d.). Amide coupling reaction in medicinal chemistry. Coupling reagents. HepatoChem.
- ACS Publications. (2009, October 14). Short and Efficient Process for the Synthesis of trans- 4-Aminocyclohexanecarboxylic Acid Derivatives. ACS Publications.

Need Custom Synthesis?

BenchChem offers custom synthesis for rare earth carbides and specific isotopic labeling.

Email: info@benchchem.com or [Request Quote Online](#).

Sources

- [1. researchgate.net \[researchgate.net\]](https://www.researchgate.net)
- [2. A Method Of Preparing Trans 4 Amino 1 Cyclohexane Carboxylic Acid \[quickcompany.in\]](https://www.quickcompany.in)
- [3. Synthesis of amide derivatives for electron deficient amines and functionalized carboxylic acids using EDC and DMAP and a catalytic amount of HOBt as the coupling reagents - PMC \[pmc.ncbi.nlm.nih.gov\]](https://pubmed.ncbi.nlm.nih.gov/19111111/)
- [4. hepatochem.com \[hepatochem.com\]](https://www.hepatochem.com)

- [5. pdf.benchchem.com \[pdf.benchchem.com\]](https://pdf.benchchem.com)
- [6. CN108602758B - Process for preparing trans-4-amino-1-cyclohexanecarboxylic acids and derivatives thereof - Google Patents \[patents.google.com\]](#)
- [7. synarchive.com \[synarchive.com\]](https://synarchive.com)
- [8. pubs.acs.org \[pubs.acs.org\]](https://pubs.acs.org)
- [9. organic-synthesis.com \[organic-synthesis.com\]](https://organic-synthesis.com)
- [10. Carbodiimide - Wikipedia \[en.wikipedia.org\]](https://en.wikipedia.org)
- [11. taylorandfrancis.com \[taylorandfrancis.com\]](https://taylorandfrancis.com)
- [12. peptide.com \[peptide.com\]](https://peptide.com)
- [13. HATU: The Core Reagent for Peptide & Drug Synthesis \[en.highfine.com\]](https://en.highfine.com)
- [14. HATU : a third-generation coupling reagent_Chemicalbook \[chemicalbook.com\]](https://chemicalbook.com)
- [15. HATU - Wikipedia \[en.wikipedia.org\]](https://en.wikipedia.org)
- [16. Amine to Amide Mechanism - HATU \[commonorganicchemistry.com\]](https://commonorganicchemistry.com)
- [17. Mechanism of amide formation by carbodiimide for bioconjugation in aqueous media - PubMed \[pubmed.ncbi.nlm.nih.gov\]](https://pubmed.ncbi.nlm.nih.gov)
- To cite this document: BenchChem. [protocol for amidation of 4-aminocyclohexanecarboxylic acid]. BenchChem, [2026]. [Online PDF]. Available at: [\[https://www.benchchem.com/product/b1523020/docs#protocol-for-amidation-of-4-aminocyclohexanecarboxylic-acid\]](https://www.benchchem.com/product/b1523020/docs#protocol-for-amidation-of-4-aminocyclohexanecarboxylic-acid)

Disclaimer & Data Validity:

The information provided in this document is for Research Use Only (RUO) and is strictly not intended for diagnostic or therapeutic procedures. While BenchChem strives to provide accurate protocols, we make no warranties, express or implied, regarding the fitness of this product for every specific experimental setup.

Technical Support: The protocols provided are for reference purposes. Unsure if this reagent suits your experiment?

Need Industrial/Bulk Grade? [Request Custom Synthesis Quote](#)

BenchChem

Our mission is to be the trusted global source of essential and advanced chemicals, empowering scientists and researchers to drive progress in science and industry.

Contact

Address: 3281 E Guasti Rd

Ontario, CA 91761, United States

Phone: (601) 213-4426

Email: info@benchchem.com

[Contact our Ph.D. Support Team for a compatibility check](#)