

# A Researcher's Guide to Differentiating C<sub>7</sub>H<sub>9</sub>N<sub>3</sub>O<sub>2</sub> Isomers by Mass Spectrometry Fragmentation

**Author:** BenchChem Technical Support Team. **Date:** April 2026

## Compound of Interest

Compound Name:	(3-Methyl-4-nitropyridin-2- YL)methanamine
CAS No.:	886372-17-4
Cat. No.:	B15227403

[Get Quote](#)

## Introduction

The molecular formula C<sub>7</sub>H<sub>9</sub>N<sub>3</sub>O<sub>2</sub> represents a variety of structural isomers, each with potentially unique chemical and biological properties. In fields ranging from pharmaceutical development to environmental analysis, the ability to unambiguously identify these isomers is paramount. Mass spectrometry (MS), particularly tandem mass spectrometry (MS/MS), stands as a cornerstone technique for this purpose. The fragmentation pattern of a molecule, its "mass spectral fingerprint," provides a wealth of structural information, allowing for the differentiation of compounds that are otherwise identical in mass and elemental composition[1][2].

This guide provides an in-depth comparison of the expected mass spectral fragmentation patterns of two key isomers of C<sub>7</sub>H<sub>9</sub>N<sub>3</sub>O<sub>2</sub>: 2,4-diamino-6-nitrotoluene and 2,6-diamino-4-nitrotoluene. As a comparative case study, we will also examine the well-documented fragmentation of Metronidazole, a related nitroimidazole compound, to highlight how distinct structural classes produce unique and identifiable fragmentation pathways. This document is

intended for researchers, scientists, and drug development professionals who utilize mass spectrometry for structural elucidation and isomer analysis.

## PART 1: Fragmentation Pathways of Diaminonitrotoluene Isomers

The diaminonitrotoluene isomers are characterized by a toluene backbone substituted with two amino groups (-NH<sub>2</sub>) and one nitro group (-NO<sub>2</sub>). Upon ionization, typically forming a protonated molecule [M+H]<sup>+</sup> in electrospray ionization (ESI), the subsequent fragmentation induced by collision-induced dissociation (CID) is dictated by the relative positions of these functional groups.

**Causality of Fragmentation:** The initial protonation site is likely one of the amino groups, as they are more basic than the nitro group. The fragmentation process is driven by the energetic instability of the ionized molecule after it collides with neutral gas molecules, converting kinetic energy into internal energy that leads to bond breakage<sup>[3][4]</sup>. The most probable fragmentation pathways involve the loss of small, stable neutral molecules from the nitro group and subsequent cleavages of the aromatic ring system.

Expected Fragmentation Pathways:

- **Loss of Hydroxyl Radical (-•OH):** A common initial fragmentation for aromatic nitro compounds involves the rearrangement and loss of a hydroxyl radical from the nitro group, resulting in an [M+H - 17]<sup>+</sup> ion.
- **Loss of Nitric Oxide (-•NO):** Subsequent to or in parallel with the loss of •OH, the loss of nitric oxide is another characteristic pathway, leading to an [M+H - 30]<sup>+</sup> fragment.
- **Loss of Nitro Group (-•NO<sub>2</sub>):** The direct cleavage of the C-NO<sub>2</sub> bond can lead to the loss of the entire nitro group, producing a significant [M+H - 46]<sup>+</sup> ion.
- **Sequential Losses:** Following the initial losses from the nitro group, further fragmentation can occur, such as the loss of ammonia (-NH<sub>3</sub>) or hydrogen cyanide (HCN) from the ring and amino groups.

The relative abundance of these fragment ions can help distinguish between isomers. For instance, steric hindrance between adjacent groups in one isomer might favor a particular rearrangement pathway over another.

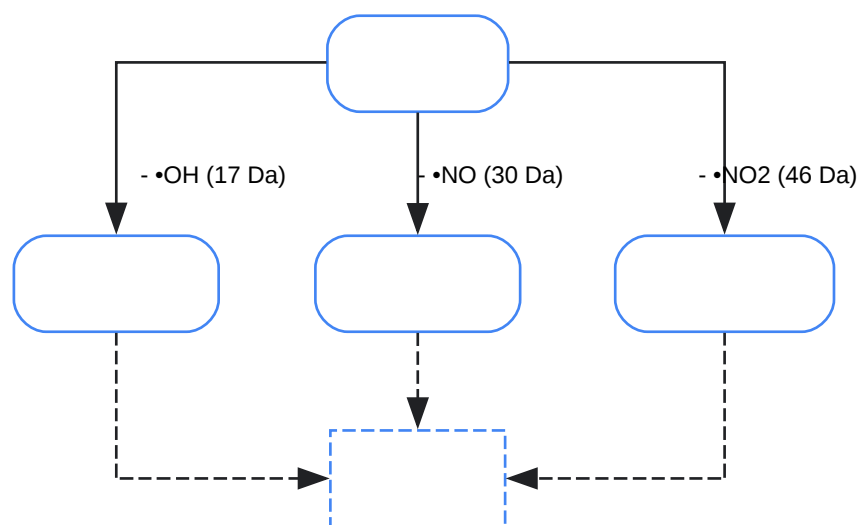

[Click to download full resolution via product page](#)

Caption: Predicted Fragmentation of Diaminonitrotoluene Isomers.

## PART 2: A Comparative Case Study: The Fragmentation of Nitroimidazoles

To illustrate how profoundly a change in the core chemical scaffold affects fragmentation, we will examine Metronidazole ( $C_6H_9N_3O_3$ ). While not a direct isomer, its status as a well-studied nitroaromatic compound provides an authoritative comparison point. The fragmentation of the metronidazole cation is known to have numerous pathways with strong energy dependence[5][6][7].

Key Fragmentation Pathways of Metronidazole:

Unlike the diaminonitrotoluenes, the fragmentation of the protonated metronidazole molecular ion is dominated by cleavages related to its imidazole ring and the attached side chain.

- Loss of NOOH: A highly characteristic fragmentation pathway for metronidazole is the ejection of nitrous acid (NOOH), a process that can occur even at low internal energies[5][6]. This results in a prominent fragment ion at  $m/z$  124.

- Loss of NO<sub>2</sub>: At higher collision energies, the loss of the nitro group (NO<sub>2</sub>) becomes a more rapid and favorable process[5][6].
- Side-Chain Fragmentation: Cleavage of the hydroxyethyl side chain is also common, leading to characteristic ions. For example, a fragment at m/z 128 is observed, corresponding to the loss of C<sub>2</sub>H<sub>3</sub>O, and a fragment at m/z 82 is also reported[8][9].

These pathways are fundamentally different from the simple neutral losses expected from diaminonitrotoluenes, providing a clear basis for differentiation.

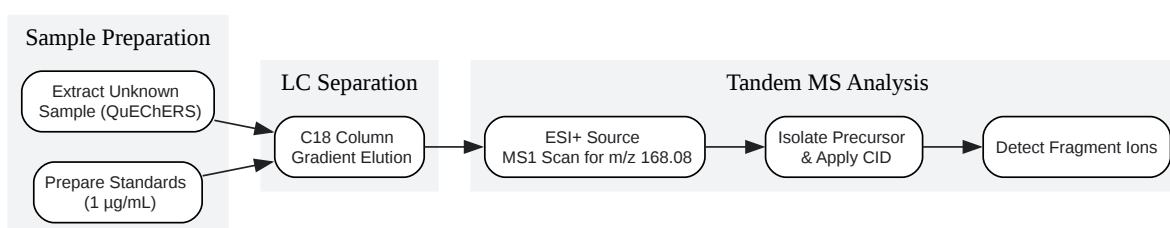
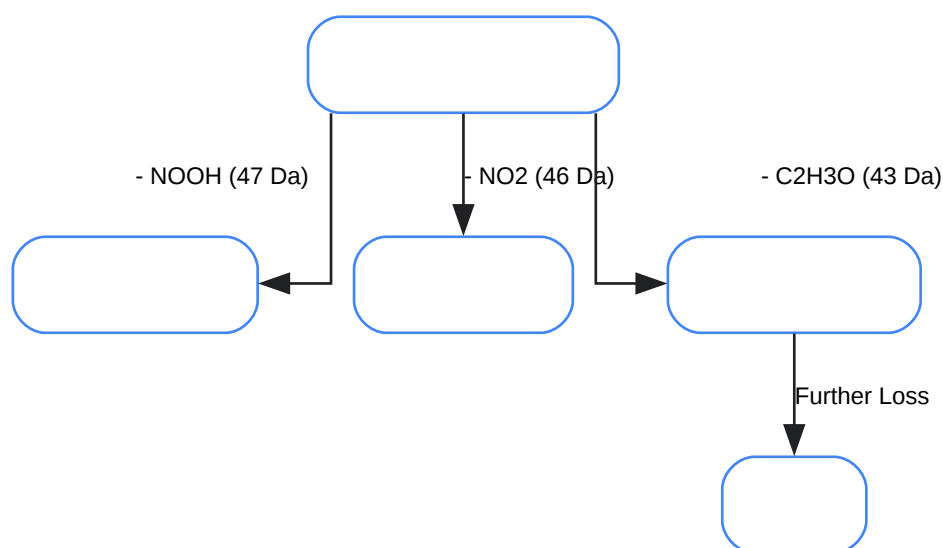

[Click to download full resolution via product page](#)

### Need Custom Synthesis?

BenchChem offers custom synthesis for rare earth carbides and specific isotopic labeling.

Email: [info@benchchem.com](mailto:info@benchchem.com) or [Request Quote Online](#).

## Sources

- [1. Fragmentation \(mass spectrometry\) - Wikipedia \[en.wikipedia.org\]](#)
- [2. studymind.co.uk \[studymind.co.uk\]](#)
- [3. Collision-induced dissociation - Wikipedia \[en.wikipedia.org\]](#)
- [4. longdom.org \[longdom.org\]](#)
- [5. utupub.fi \[utupub.fi\]](#)
- [6. pubs.acs.org \[pubs.acs.org\]](#)
- [7. Fragmentation Patterns of Radiosensitizers Metronidazole and Nimorazole upon Valence Ionization - PubMed \[pubmed.ncbi.nlm.nih.gov\]](#)
- [8. Simultaneous Determination of Nitroimidazoles and Quinolones in Honey by Modified QuEChERS and LC-MS/MS Analysis - PMC \[pmc.ncbi.nlm.nih.gov\]](#)
- [9. researchgate.net \[researchgate.net\]](#)
- To cite this document: BenchChem. [A Researcher's Guide to Differentiating C7H9N3O2 Isomers by Mass Spectrometry Fragmentation]. BenchChem, [2026]. [Online PDF]. Available at: [<https://www.benchchem.com/product/b15227403/docs#a-researcher-s-guide-to-differentiating-c7h9n3o2-isomers-by-mass-spectrometry-fragmentation>]

---

### Disclaimer & Data Validity:

The information provided in this document is for Research Use Only (RUO) and is strictly not intended for diagnostic or therapeutic procedures. While BenchChem strives to provide accurate protocols, we make no warranties, express or implied, regarding the fitness of this product for every specific experimental setup.

**Technical Support:** The protocols provided are for reference purposes. Unsure if this reagent suits your experiment?

**Need Industrial/Bulk Grade?** [Request Custom Synthesis Quote](#)

# BenchChem

Our mission is to be the trusted global source of essential and advanced chemicals, empowering scientists and researchers to drive progress in science and industry.

## Contact

Address: 3281 E Guasti Rd

Ontario, CA 91761, United States

Phone: (601) 213-4426

Email: [info@benchchem.com](mailto:info@benchchem.com)

[Contact our Ph.D. Support Team for a compatibility check](#)