

Technical Support Center: Troubleshooting Boc Deprotection of Complex Indoline Derivatives

Author: BenchChem Technical Support Team. **Date:** May 2026

Compound of Interest

Compound Name: *Tert-butyl 5-bromo-4-hydroxyindoline-1-carboxylate*

CAS No.: 1092460-53-1

Cat. No.: B1522209

[Get Quote](#)

Welcome to the technical support center for synthetic chemistry. This guide is designed for researchers, scientists, and drug development professionals who are navigating the complexities of N-Boc (tert-butyloxycarbonyl) deprotection, specifically for intricate indoline scaffolds. Indoline derivatives are privileged structures in medicinal chemistry, but their successful manipulation requires a nuanced understanding of their electronic properties and potential side reactions. This document provides in-depth, field-proven insights to help you troubleshoot common challenges and optimize your synthetic outcomes.

Section 1: Core Principles - The "Why" of Boc Deprotection Chemistry

The Boc group is a cornerstone of amine protection strategy due to its general stability under basic and nucleophilic conditions, and its clean removal under acidic conditions.^[1] The deprotection mechanism is an acid-catalyzed elimination. The process begins with the protonation of the carbamate oxygen, which weakens the C-O bond. This leads to the loss of a stable tert-butyl cation and the formation of an unstable carbamic acid intermediate, which rapidly decarboxylates to yield the free amine and carbon dioxide gas.^{[2][3]}

Understanding this mechanism is crucial for troubleshooting. The generation of the highly reactive tert-butyl cation is the primary source of many side reactions, particularly with electron-rich aromatic systems like indolines.[4][5]

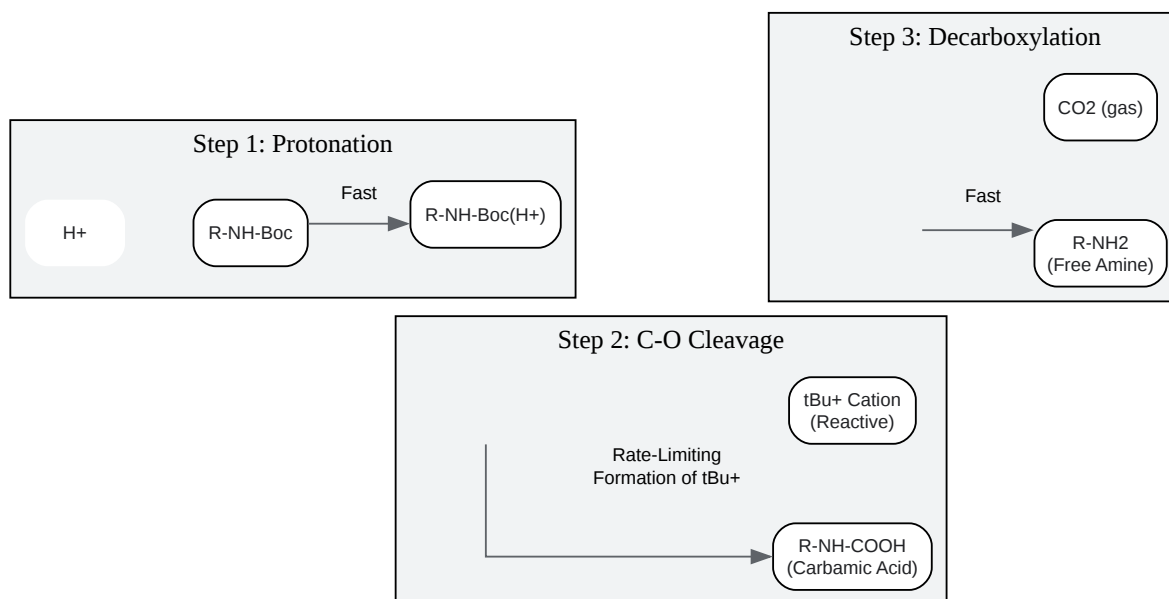

[Click to download full resolution via product page](#)

Caption: Acid-catalyzed Boc deprotection mechanism.

Section 2: Frequently Asked Questions & Troubleshooting Guide

This section addresses the most common issues encountered during the Boc deprotection of indoline derivatives in a practical, question-and-answer format.

Q1: My deprotection reaction is sluggish or incomplete. What should I do?

Answer: This is a frequent challenge, often stemming from insufficient acid strength, steric hindrance, or electronic effects within your specific indoline derivative.[6]

Causality & Troubleshooting Steps:

- Insufficient Acid: The indoline nitrogen itself, or other basic functional groups on your molecule, can consume the acid, reducing its effective concentration.[7]
 - Solution: Gradually increase the equivalents of acid (e.g., move from 20% TFA in DCM to 50%, or use a higher concentration of HCl in dioxane).[8] Monitor closely by TLC to avoid degradation.
- Steric Hindrance: Bulky substituents near the N-Boc group can physically block the acid from accessing the carbamate oxygen.[9][10]
 - Solution: If increasing acid concentration is ineffective or causes decomposition, gentle heating (e.g., 40-50 °C) can provide the necessary activation energy.[8] Always monitor carefully, as heat can accelerate side reactions.
- Electronic Effects: Electron-withdrawing groups on the indoline ring can destabilize the transition state, slowing the reaction.[6][9]
 - Solution: More forcing conditions, such as longer reaction times or a stronger acid system (e.g., neat TFA if the substrate can tolerate it), may be required.
- Reagent Quality: Trifluoroacetic acid (TFA) is hygroscopic. Water contamination can reduce its effective acidity and slow the reaction.[7]
 - Solution: Use a fresh, unopened bottle of TFA or an anhydrous grade of HCl in dioxane.

Q2: I'm observing significant side product formation. What are they and how can I prevent them?

Answer: The most common side reaction is the alkylation of your molecule by the tert-butyl cation generated during deprotection.[5] The electron-rich indoline ring, particularly at the C5 and C7 positions, is highly susceptible to this electrophilic attack.[4]

Mitigation Strategies: The Use of Scavengers

Scavengers are nucleophilic compounds added in excess to the reaction mixture to "trap" the tert-butyl cation before it can react with your product.^{[4][11]}

Scavenger	Application Notes	Typical Concentration
Triethylsilane (TES) or Triisopropylsilane (TIS)	Highly effective. Reduces the tert-butyl cation to isobutane. TIS is more sterically hindered and can be more selective.	5-10% (v/v)
Anisole or Thioanisole	Classical scavengers that act as cation traps via electrophilic aromatic substitution. Thioanisole is often more effective.	5-10% (v/v)
Water	Can act as a scavenger but may not be suitable for all substrates or reaction conditions. Can reduce the effective acidity.	1-5% (v/v)
1,2-Ethanedithiol (EDT)	Particularly useful for protecting tryptophan residues, which are structurally similar to indolines.	2-5% (v/v)

Recommendation: For complex indolines, starting with 5% triisopropylsilane (TIS) is a robust first choice to minimize side reactions.

Q3: My starting material is degrading. How can I deprotect the Boc group in the presence of other acid-sensitive functional groups?

Answer: This is a critical challenge in multi-step synthesis. Harsh acidic conditions (like 50% TFA) can cleave other protecting groups (e.g., t-butyl esters, silyl ethers) or damage sensitive

functionalities on the indoline core.[12]

Strategy: Milder Deprotection Methods

When standard TFA or HCl conditions are too harsh, several milder alternatives can be employed.

Method	Reagents & Conditions	Advantages & Considerations
HCl in Dioxane/MeOH	4M HCl in Dioxane or Methanol, RT.[13][14]	Generally milder than TFA. The product is often isolated as the HCl salt, which can aid in purification.[15]
Oxalyl Chloride in MeOH	3 eq. Oxalyl Chloride in Methanol, RT.[8][16]	Very mild and suitable for substrates with acid-sensitive groups. The mechanism is more complex than simple in-situ HCl generation.[9][17]
Lewis Acids (e.g., ZnBr ₂)	2-3 eq. ZnBr ₂ in DCM, RT.[18]	Offers good selectivity for N-Boc groups over other acid-labile groups. Reaction times can be longer (24-72h).
Thermal Deprotection	Reflux in a high-boiling solvent like TFE or a Dioxane/Water mixture.[12][18]	Avoids strong acids entirely. Only suitable for thermally stable molecules. Can be highly selective.[19]

Q4: How can I effectively monitor the reaction progress?

Answer: Thin-Layer Chromatography (TLC) is the most direct and efficient method.[7]

Expert Tip: The deprotected indoline product is a free amine and will be protonated in the acidic reaction mixture, which can cause streaking on the TLC plate. To get a clean spot, take a small aliquot of the reaction mixture, dilute it in a solvent like ethyl acetate, and add a drop of a mild base (like triethylamine or saturated NaHCO₃ solution) to neutralize the acid before spotting it

on the TLC plate.[20] The deprotected amine product will be significantly more polar (lower R_f) than the N-Boc starting material and should be ninhydrin-positive.

Q5: What are the best practices for work-up and purification?

Answer: A proper work-up is essential to remove acidic reagents and byproducts.

- **Neutralization:** After the reaction is complete (as determined by TLC), the mixture is typically concentrated to remove the bulk of the acid. The residue is then redissolved in an organic solvent (e.g., ethyl acetate or DCM) and carefully washed with a saturated aqueous solution of sodium bicarbonate (NaHCO₃) or a mild base until CO₂ evolution ceases.[8][14] This neutralizes any remaining acid.
- **Extraction:** Following the basic wash, wash the organic layer with brine to remove excess water. Dry the organic layer over anhydrous sodium sulfate (Na₂SO₄) or magnesium sulfate (MgSO₄), filter, and concentrate under reduced pressure.
- **Purification:** The crude product can then be purified.
 - **Column Chromatography:** Standard silica gel chromatography is most common. The increased polarity of the free amine product usually allows for good separation from less polar impurities.
 - **Acidic Resin Capture:** For difficult separations, the crude product can be passed through a strong cation exchange (SCX) resin. The basic amine product binds to the resin, allowing neutral impurities to be washed away. The product is then eluted by washing the resin with a solution of ammonia in methanol.[21]

Section 3: Experimental Protocols & Workflow

This section provides standardized, step-by-step protocols for common deprotection methods.

Protocol 1: Standard Deprotection with TFA/DCM

- Dissolve the N-Boc protected indoline (1.0 equiv.) in dichloromethane (DCM) to a concentration of approximately 0.1 M.

- If required, add a scavenger such as triisopropylsilane (TIS, 0.5-1.0 equiv., ~5% v/v).
- Cool the solution to 0 °C in an ice bath.
- Slowly add trifluoroacetic acid (TFA) to the desired concentration (typically 20-50% v/v).[8]
- Stir the reaction at 0 °C for 30 minutes, then allow it to warm to room temperature.
- Monitor the reaction progress by TLC every 30-60 minutes.[20]
- Upon completion, concentrate the reaction mixture under reduced pressure.
- Proceed with the standard neutralization and extraction work-up as described in Q5.

Protocol 2: Milder Deprotection with HCl in Dioxane

- Dissolve the N-Boc protected indoline (1.0 equiv.) in a minimal amount of a co-solvent like methanol or DCM if solubility is an issue.
- Add a 4M solution of HCl in dioxane (5-10 equiv.) at room temperature.[14]
- Stir the reaction for 2-16 hours, monitoring by TLC.[13]
- Upon completion, the product may precipitate as the hydrochloride salt, which can be collected by filtration.
- Alternatively, the solvent can be removed under reduced pressure to yield the crude salt.
- To obtain the free base, dissolve the salt in an organic solvent and perform the neutralization wash as described in Q5.

Protocol 3: Alternative Deprotection with Oxalyl Chloride

- Dissolve the N-Boc protected indoline (1.0 equiv.) in anhydrous methanol to a concentration of approximately 0.1 M.
- At room temperature, add oxalyl chloride (3.0 equiv.) dropwise to the solution.[8]
- Stir the reaction for 1-4 hours, monitoring by TLC.

- Upon completion, concentrate the reaction mixture under reduced pressure.
- Redissolve the residue in an organic solvent (e.g., ethyl acetate) and perform the standard neutralization wash with saturated NaHCO_3 solution as described in Q5.[8]

Troubleshooting Workflow

Use the following diagram to guide your experimental decisions when encountering issues.

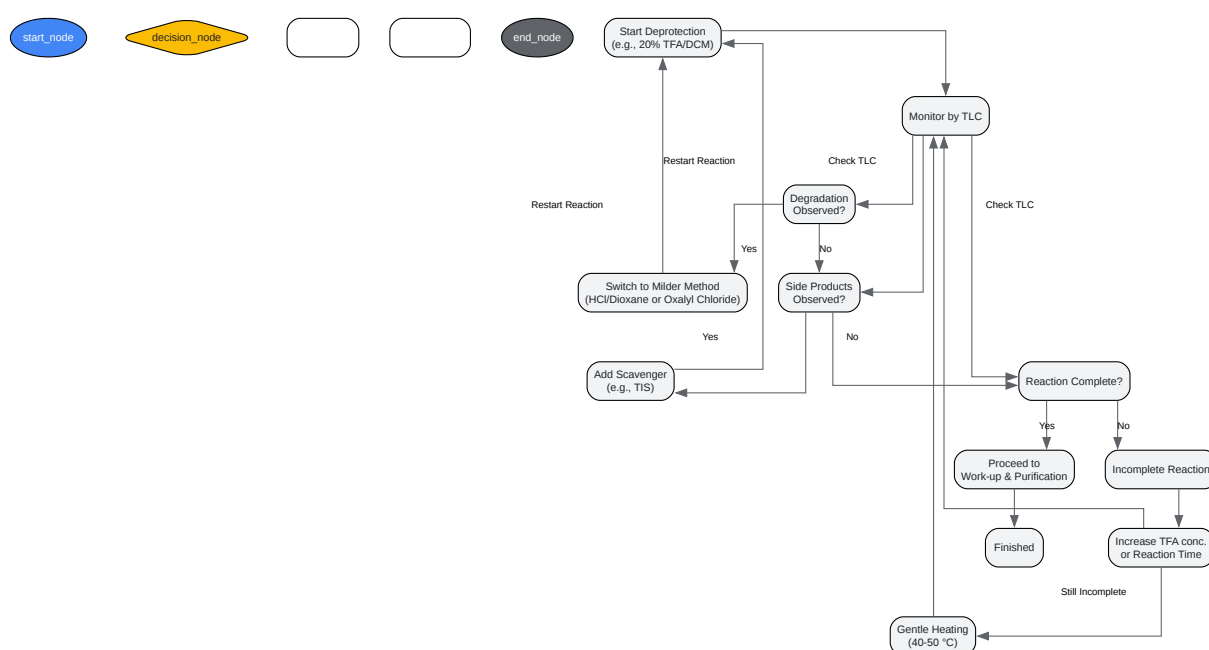

[Click to download full resolution via product page](#)

Caption: Decision workflow for troubleshooting Boc deprotection.

References

- Indole N-Boc deprotection method development. (n.d.). ResearchGate. Retrieved January 20, 2026, from [\[Link\]](#)
- Boc Deprotection Mechanism - TFA. (n.d.). Common Organic Chemistry. Retrieved January 20, 2026, from [\[Link\]](#)
- Simple and Selective Removal of the t-Butyloxycarbonyl (Boc) Protecting Group on Indoles, Pyrroles, Indazoles, and Carbolines. (2006). ResearchGate. Retrieved January 20, 2026, from [\[Link\]](#)
- Boc Deprotection - HCl. (n.d.). Common Organic Chemistry. Retrieved January 20, 2026, from [\[Link\]](#)
- George, N., Ofori, S., Parkin, S., & Awuah, S. G. (2020). Mild deprotection of the N-tert-butyloxycarbonyl (N-Boc) group using oxalyl chloride. *RSC Advances*, 10(41), 24551–24558. [\[Link\]](#)
- George, N., Ofori, S., Parkin, S., & Awuah, S. G. (2020). Mild deprotection of the N-tert-butyloxycarbonyl (N-Boc) group using oxalyl chloride. National Institutes of Health. Retrieved January 20, 2026, from [\[Link\]](#)
- Advice on N-boc deprotection in the presence of acid sensitive groups. (2022). Reddit. Retrieved January 20, 2026, from [\[Link\]](#)
- Deprotection of N-tert-Butoxycarbonyl (Boc) Protected Functionalized Heteroarenes via Addition–Elimination with 3-Methoxypropylamine. (2023). ResearchGate. Retrieved January 20, 2026, from [\[Link\]](#)
- The deprotection of the N-Ts and N-Boc group. (n.d.). ResearchGate. Retrieved January 20, 2026, from [\[Link\]](#)
- Amine Protection and Deprotection. (n.d.). Master Organic Chemistry. Retrieved January 20, 2026, from [\[Link\]](#)

- BOC Deprotection. (n.d.). ACS GCI Pharmaceutical Roundtable Reagent Guides. Retrieved January 20, 2026, from [\[Link\]](#)
- Indole. (n.d.). Wikipedia. Retrieved January 20, 2026, from [\[Link\]](#)
- Fast, efficient and selective deprotection of the tert-butoxycarbonyl (Boc) group using HCl/dioxane (4 m). (2001). Journal of Peptide Research, 58(4), 338-341. [\[Link\]](#)
- Mild deprotection of the N-tert-butyloxycarbonyl (N-Boc) group using oxalyl chloride. (2020). Semantic Scholar. Retrieved January 20, 2026, from [\[Link\]](#)
- Boc Deprotection Mechanism - HCl. (n.d.). Common Organic Chemistry. Retrieved January 20, 2026, from [\[Link\]](#)
- Boc Deprotection Mechanism | Organic Chemistry. (2022). YouTube. Retrieved January 20, 2026, from [\[Link\]](#)
- Mild deprotection of the N-tert-butyloxycarbonyl (N-Boc) group using oxalyl chloride. (2020). RSC Advances. Retrieved January 20, 2026, from [\[Link\]](#)
- BOC Protection and Deprotection. (n.d.). Hebei Boze Chemical Co., Ltd. Retrieved January 20, 2026, from [\[Link\]](#)
- Facile Synthesis and Altered Ionization Efficiency of Diverse N ϵ -Alkyllysine Containing Peptides. (n.d.). The Royal Society of Chemistry. Retrieved January 20, 2026, from [\[Link\]](#)
- Simultaneous Deprotection and Purification of BOC-amines Based on Ionic Resin Capture. (1998). Journal of Organic Chemistry. Retrieved January 20, 2026, from [\[Link\]](#)
- Selective Thermal Deprotection of N-Boc Protected Amines in Continuous Flow. (2021). Organic Process Research & Development. Retrieved January 20, 2026, from [\[Link\]](#)
- Synthesis of indoles. (n.d.). Organic Chemistry Portal. Retrieved January 20, 2026, from [\[Link\]](#)
- Functional Group Characteristics and Roles. (n.d.). ASHP. Retrieved January 20, 2026, from [\[Link\]](#)

- Carbonylative synthesis and functionalization of indoles. (2022). Beilstein Journal of Organic Chemistry. Retrieved January 20, 2026, from [[Link](#)]
- Indolizinoquinolinedione Metal Complexes: Structural Characterization, In Vitro Antibacterial, and In Silico Studies. (2023). MDPI. Retrieved January 20, 2026, from [[Link](#)]
- Steric hindrance classified: treatment of isothiocyanatoallene with secondary amines bearing bulky substituents to generate 2-aminothiazoles. (2019). Organic Chemistry Frontiers. Retrieved January 20, 2026, from [[Link](#)]

Need Custom Synthesis?

BenchChem offers custom synthesis for rare earth carbides and specific isotopic labeling.

Email: info@benchchem.com or [Request Quote Online](#).

Sources

- [1. masterorganicchemistry.com](https://www.masterorganicchemistry.com) [[masterorganicchemistry.com](https://www.masterorganicchemistry.com)]
- [2. Boc Deprotection Mechanism - TFA](https://www.commonorganicchemistry.com) [[commonorganicchemistry.com](https://www.commonorganicchemistry.com)]
- [3. Boc Deprotection Mechanism - HCl](https://www.commonorganicchemistry.com) [[commonorganicchemistry.com](https://www.commonorganicchemistry.com)]
- [4. pdf.benchchem.com](https://pdf.benchchem.com) [pdf.benchchem.com]
- [5. BOC Deprotection - Wordpress](https://reagents.acsgcipr.org) [reagents.acsgcipr.org]
- [6. pdf.benchchem.com](https://pdf.benchchem.com) [pdf.benchchem.com]
- [7. pdf.benchchem.com](https://pdf.benchchem.com) [pdf.benchchem.com]
- [8. pdf.benchchem.com](https://pdf.benchchem.com) [pdf.benchchem.com]
- [9. Mild deprotection of the N-tert-butyloxycarbonyl \(N-Boc\) group using oxalyl chloride - PMC](https://pubmed.ncbi.nlm.nih.gov) [[pmc.ncbi.nlm.nih.gov](https://pubmed.ncbi.nlm.nih.gov)]
- [10. pdf.benchchem.com](https://pdf.benchchem.com) [pdf.benchchem.com]
- [11. pdf.benchchem.com](https://pdf.benchchem.com) [pdf.benchchem.com]
- [12. reddit.com](https://www.reddit.com) [[reddit.com](https://www.reddit.com)]
- [13. Boc Deprotection - HCl](https://www.commonorganicchemistry.com) [[commonorganicchemistry.com](https://www.commonorganicchemistry.com)]
- [14. pdf.benchchem.com](https://pdf.benchchem.com) [pdf.benchchem.com]

- 15. Fast, efficient and selective deprotection of the tert-butoxycarbonyl (Boc) group using HCl/dioxane (4 m) - PubMed [pubmed.ncbi.nlm.nih.gov]
- 16. Mild deprotection of the N-tert -butyloxycarbonyl (N -Boc) group using oxalyl chloride - RSC Advances (RSC Publishing) DOI:10.1039/D0RA04110F [pubs.rsc.org]
- 17. Mild deprotection of the N-tert-butyloxycarbonyl (N-Boc) group using oxalyl chloride - RSC Advances (RSC Publishing) [pubs.rsc.org]
- 18. pdf.benchchem.com [pdf.benchchem.com]
- 19. pubs.acs.org [pubs.acs.org]
- 20. pdf.benchchem.com [pdf.benchchem.com]
- 21. semanticscholar.org [semanticscholar.org]
- To cite this document: BenchChem. [Technical Support Center: Troubleshooting Boc Deprotection of Complex Indoline Derivatives]. BenchChem, [2026]. [Online PDF]. Available at: [https://www.benchchem.com/product/b1522209/docs#technical-support-center-troubleshooting-boc-deprotection-of-complex-indoline-derivatives]

Disclaimer & Data Validity:

The information provided in this document is for Research Use Only (RUO) and is strictly not intended for diagnostic or therapeutic procedures. While BenchChem strives to provide accurate protocols, we make no warranties, express or implied, regarding the fitness of this product for every specific experimental setup.

Technical Support: The protocols provided are for reference purposes. Unsure if this reagent suits your experiment?

Need Industrial/Bulk Grade? [Request Custom Synthesis Quote](#)

BenchChem

Our mission is to be the trusted global source of essential and advanced chemicals, empowering scientists and researchers to drive progress in science and industry.

Contact

Address: 3281 E Guasti Rd
Ontario, CA 91761, United States
Phone: (601) 213-4426
Email: info@benchchem.com

Contact our Ph.D. Support Team for a compatibility check