

Technical Support Center: Alternative Reagents for the Oxidative Cyclization of Hydrazones

Author: BenchChem Technical Support Team. **Date:** May 2026

Compound of Interest

Compound Name: 5-(4-Methylthiophen-2-yl)-1,3,4-oxadiazol-2-amine

CAS No.: 1219827-55-0

Cat. No.: B1521035

[Get Quote](#)

Welcome to the technical support center dedicated to the oxidative cyclization of hydrazones. This guide is designed for researchers, scientists, and drug development professionals seeking to explore alternative reagents and troubleshoot common experimental challenges. In this comprehensive resource, we will delve into the nuances of various modern oxidative methods, moving beyond classical approaches to provide you with a robust understanding of the underlying chemistry and practical solutions to perfect your synthetic strategies.

Introduction

The oxidative cyclization of hydrazones is a cornerstone transformation in heterocyclic chemistry, providing access to a diverse array of valuable scaffolds such as pyrazoles, pyrazolines, 1,3,4-oxadiazoles, and indazoles. While traditional methods often rely on heavy metal oxidants with inherent toxicity and disposal issues, the field has evolved towards more sustainable and efficient alternatives. This guide will focus on four key classes of modern reagents: Hypervalent Iodine Reagents, Quinone-Based Oxidants, Oxone®, and Electrochemical Synthesis. For each, we will explore the mechanistic underpinnings, provide

detailed experimental protocols, and, most importantly, address the common pitfalls you may encounter in the laboratory.

Frequently Asked Questions (FAQs)

Q1: My oxidative cyclization is not proceeding to completion, and I'm recovering starting hydrazone. What are the first things I should check?

A: This is a common issue that can often be resolved by systematically evaluating several factors:

- **Reagent Quality:** Ensure your oxidizing agent is fresh and has been stored correctly. Hypervalent iodine reagents can be sensitive to moisture, and the potency of Oxone® can degrade over time.
- **Solvent Purity:** Anhydrous conditions are crucial for many of these reactions. Ensure your solvents are thoroughly dried, as water can interfere with the oxidant or lead to unwanted side reactions.^[1]
- **Reaction Temperature:** Some oxidative cyclizations require specific temperature control. If the reaction is sluggish at room temperature, a modest increase in temperature may be necessary. Conversely, for highly reactive substrates, cooling the reaction might prevent decomposition.
- **Stoichiometry:** Double-check the stoichiometry of your reagents. An insufficient amount of oxidant is a primary reason for incomplete conversion.

Q2: I'm observing the formation of multiple products in my reaction. How can I improve the selectivity?

A: Product selectivity is a nuanced challenge influenced by both the substrate and the reaction conditions.

- **Choice of Oxidant:** The choice of oxidizing agent can dramatically influence the reaction outcome. For instance, in the synthesis of pyrazolines from β,γ -unsaturated hydrazones, controlling the reaction atmosphere can lead to divergent outcomes.^[2]

- **Reaction Time:** Over-oxidation can lead to the formation of undesired byproducts. Monitor your reaction closely by TLC and quench it as soon as the starting material is consumed.
- **Additives:** The presence of acids or bases can significantly impact selectivity. For example, in some PIDA-mediated cyclizations, the addition of a mild acid can promote the desired pathway.[3]

Q3: Are there any "green" or more sustainable alternatives for oxidative cyclization?

A: Absolutely. The field is increasingly moving towards environmentally benign methods.

- **Electrochemical Synthesis:** This method replaces chemical oxidants with an electric current, minimizing waste.[4][5][6] It offers high levels of control and can often be performed under mild conditions.
- **Iodine-Catalyzed Systems:** While stoichiometric iodine is used, catalytic systems with a co-oxidant like hydrogen peroxide are being developed, reducing the overall iodine waste.[7]
- **Oxone®:** This reagent is an inexpensive and environmentally friendly oxidant, with its primary byproduct being potassium sulfate.[8][9]

Troubleshooting Guides & Experimental Protocols

Hypervalent Iodine Reagents: Phenyliodine(III) Diacetate (PIDA)

Hypervalent iodine reagents like Phenyliodine(III) Diacetate (PIDA) are favored for their mild reaction conditions and broad functional group tolerance.[10][11] They are particularly effective in the synthesis of various nitrogen-containing heterocycles.[3]

Problem	Potential Cause	Troubleshooting Steps & Solutions
Low or No Yield	1. Degraded PIDA: PIDA is sensitive to moisture and light.	1. Use freshly opened PIDA or store it in a desiccator, protected from light.
2. Sub-optimal Solvent: The polarity of the solvent can significantly affect the reaction rate.	2. Screen a range of solvents. Dichloromethane (DCM) or acetonitrile are common starting points. For less reactive substrates, more polar solvents might be beneficial.[3]	
3. Presence of Water: Water can hydrolyze PIDA and the reaction intermediates.	3. Ensure all glassware is oven-dried and use anhydrous solvents.	
Formation of Side Products (e.g., Acetoxylation)	1. Reaction Temperature Too High: Elevated temperatures can lead to non-selective reactions.	1. Run the reaction at room temperature or even 0 °C to improve selectivity.
2. Incorrect Stoichiometry: An excess of PIDA can lead to over-oxidation or side reactions.	2. Use a stoichiometric amount of PIDA (typically 1.1-1.5 equivalents).	
Reaction Stalls	1. Inadequate Acid Catalyst: Some PIDA-mediated cyclizations require an acid co-catalyst to proceed efficiently.	1. Add a catalytic amount of a Brønsted or Lewis acid (e.g., TFA, BF ₃ ·OEt ₂) to activate the PIDA.[3]

- To a solution of the α -indolylhydrazone (0.2 mmol) in CH₂Cl₂ (2 mL), add iodylbenzene (PhIO₂) (2.3 equivalents).
- Add trifluoroacetic acid (TFA) (30 mol %).
- Stir the reaction mixture at room temperature for 5 hours.

- Monitor the reaction progress by Thin Layer Chromatography (TLC).
- Upon completion, quench the reaction with a saturated aqueous solution of $\text{Na}_2\text{S}_2\text{O}_3$.
- Extract the product with CH_2Cl_2 (3 x 10 mL).
- Combine the organic layers, dry over anhydrous Na_2SO_4 , filter, and concentrate under reduced pressure.
- Purify the crude product by column chromatography on silica gel.

Workflow for PIDA-Mediated Oxidative Cyclization

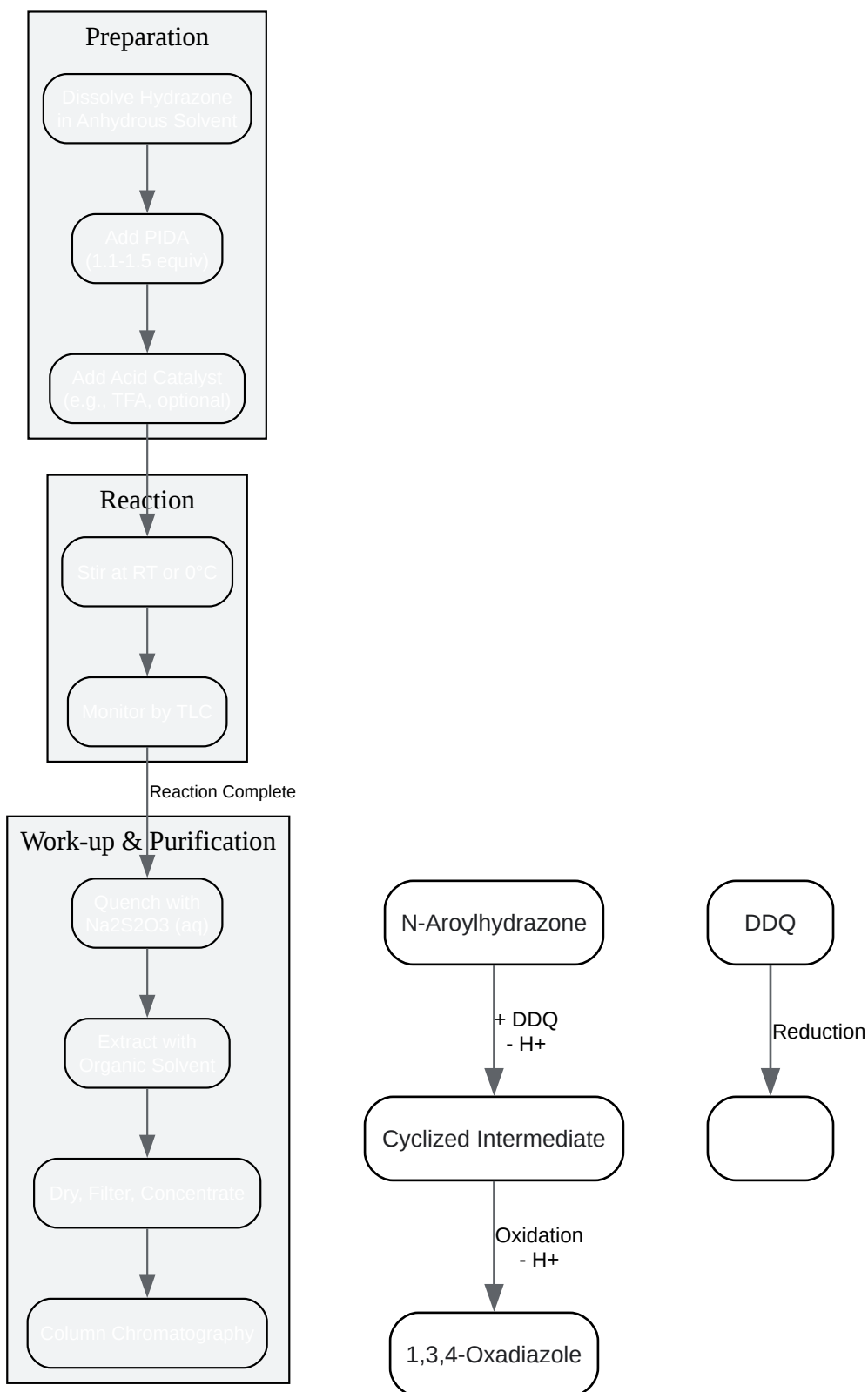

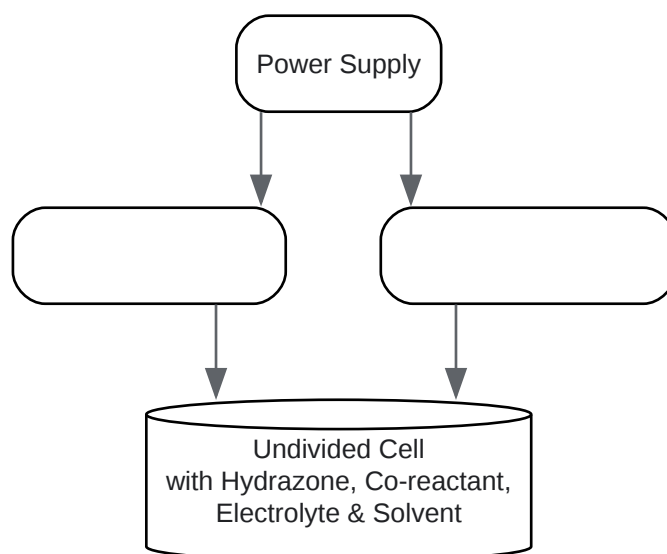

[Click to download full resolution via product page](#)

Need Custom Synthesis?

BenchChem offers custom synthesis for rare earth carbides and specific isotopic labeling.

Email: info@benchchem.com or [Request Quote Online](#).

Sources

- [1. Hydrazone iodination - Wikipedia \[en.wikipedia.org\]](#)
- [2. Pyrazoline synthesis \[organic-chemistry.org\]](#)
- [3. pubs.acs.org \[pubs.acs.org\]](#)
- [4. Harnessing the versatility of hydrazones through electrochemical oxidative transformations - PMC \[pmc.ncbi.nlm.nih.gov\]](#)
- [5. researchgate.net \[researchgate.net\]](#)
- [6. Electrochemical cycloaddition of hydrazones with cyanamide for the synthesis of substituted 5-amine-1,2,4-triazoles - Chemical Communications \(RSC Publishing\) \[pubs.rsc.org\]](#)
- [7. researchgate.net \[researchgate.net\]](#)
- [8. Recent Advances in the Oxone-Mediated Synthesis of Heterocyclic Compounds - PMC \[pmc.ncbi.nlm.nih.gov\]](#)

- [9. researchgate.net \[researchgate.net\]](#)
- [10. researchgate.net \[researchgate.net\]](#)
- [11. Iodosobenzene Diacetate \[organic-chemistry.org\]](#)
- To cite this document: BenchChem. [Technical Support Center: Alternative Reagents for the Oxidative Cyclization of Hydrazones]. BenchChem, [2026]. [Online PDF]. Available at: [\[https://www.benchchem.com/product/b1521035/docs#technical-support-center-alternative-reagents-for-the-oxidative-cyclization-of-hydrazones\]](https://www.benchchem.com/product/b1521035/docs#technical-support-center-alternative-reagents-for-the-oxidative-cyclization-of-hydrazones)

Disclaimer & Data Validity:

The information provided in this document is for Research Use Only (RUO) and is strictly not intended for diagnostic or therapeutic procedures. While BenchChem strives to provide accurate protocols, we make no warranties, express or implied, regarding the fitness of this product for every specific experimental setup.

Technical Support: The protocols provided are for reference purposes. Unsure if this reagent suits your experiment?

Need Industrial/Bulk Grade? [Request Custom Synthesis Quote](#)

BenchChem

Our mission is to be the trusted global source of essential and advanced chemicals, empowering scientists and researchers to drive progress in science and industry.

Contact

Address: 3281 E Guasti Rd
Ontario, CA 91761, United States
Phone: (601) 213-4426
Email: info@benchchem.com

[Contact our Ph.D. Support Team for a compatibility check](#)

