

Navigating the Combes Quinoline Synthesis: A Technical Guide to Overcoming Poor Regioselectivity

Author: BenchChem Technical Support Team. **Date:** May 2026

Compound of Interest

Compound Name:	7-Bromo-2,8-dimethylquinoline-3-carboxylic acid
CAS No.:	1189106-92-0
Cat. No.:	B1520180

[Get Quote](#)

Welcome to the Technical Support Center for the Combes Quinoline Synthesis. This guide is designed for researchers, scientists, and drug development professionals who are utilizing the Combes reaction for the synthesis of substituted quinolines and are encountering challenges with regioselectivity. As a Senior Application Scientist, my goal is to provide you with in-depth technical guidance, field-proven insights, and practical troubleshooting strategies to help you achieve your desired synthetic outcomes.

The Combes synthesis, a powerful acid-catalyzed condensation of anilines and β -diketones, is a cornerstone in the construction of the quinoline scaffold, a privileged core in medicinal chemistry.^{[1][2]} However, the use of unsymmetrical β -diketones often leads to the formation of a mixture of regioisomers, complicating purification and reducing the yield of the desired product. This guide will dissect the factors governing this regioselectivity and provide actionable protocols to steer the reaction towards your target molecule.

Understanding the Challenge: The Root of Poor Regioselectivity

The regiochemical outcome of the Combes synthesis is determined during the intramolecular electrophilic aromatic substitution (annulation) step, which is often the rate-determining step of the reaction.^[1] When an unsymmetrical β -diketone is used, two different enamine intermediates can form, leading to two potential cyclization pathways and, consequently, two regioisomeric quinoline products.

The preferred pathway is a delicate balance of steric and electronic effects of the substituents on both the aniline and the β -diketone.^[1]

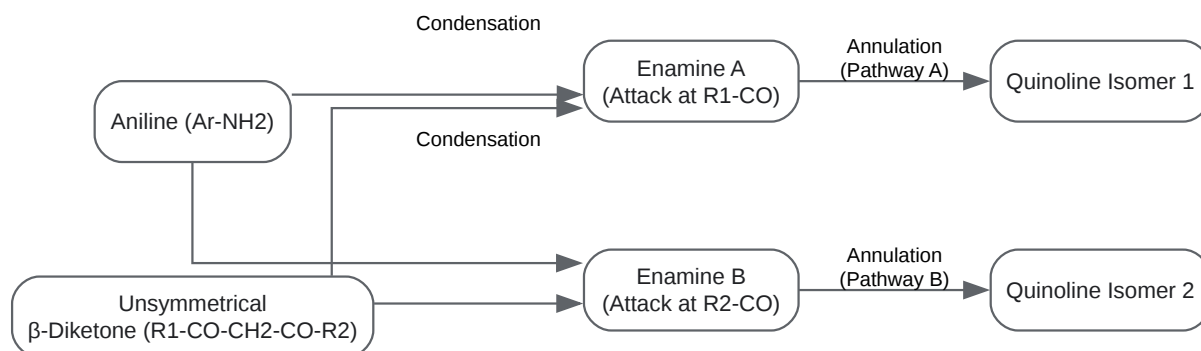

[Click to download full resolution via product page](#)

Caption: Competing pathways in the Combes synthesis leading to regioisomers.

Frequently Asked Questions (FAQs)

Q1: I'm getting a nearly 1:1 mixture of regioisomers. How can I improve the selectivity?

A1: A 1:1 mixture suggests that the electronic and steric factors governing the cyclization are not significantly different for the two competing pathways. To improve selectivity, you need to amplify these differences. Consider the following strategies:

- Modify the β -Diketone: Introduce a substituent with a significant steric bulk on one side of the diketone. The cyclization will preferentially occur at the less sterically hindered carbonyl

group.

- **Modify the Aniline:** The electronic nature of the substituents on the aniline ring plays a crucial role. Electron-donating groups (EDGs) on the aniline can enhance the nucleophilicity of the aromatic ring and potentially favor one cyclization pathway over the other. Conversely, electron-withdrawing groups (EWGs) can also influence the regioselectivity.^[1]
- **Change the Catalyst:** Traditional strong acids like sulfuric acid can be aggressive and may not offer the best selectivity. Switching to a milder and bulkier catalyst system like Polyphosphoric Acid (PPA) or Polyphosphoric Ester (PPE) can significantly improve regioselectivity.^[1]

Q2: I'm observing the formation of an unexpected major regioisomer. What could be the reason?

A2: This indicates that your initial assumptions about the directing effects of your substituents may be incorrect or that other factors are at play. Here's what to consider:

- **Re-evaluate Electronic Effects:** The interplay of inductive and resonance effects can be complex. For instance, in the synthesis of trifluoromethylquinolines, methoxy-substituted anilines tend to yield 2-CF₃-quinolines, while chloro- or fluoro-substituted anilines favor the formation of the 4-CF₃ regioisomer.^[1]
- **Consider Reaction Temperature:** In some cases, regioselectivity can be temperature-dependent. A higher temperature might provide enough energy to overcome the activation barrier for the formation of the thermodynamically less favorable product. Try running the reaction at a lower temperature for a longer duration.
- **Intermediate Stability:** The relative stability of the two possible enamine intermediates can also influence the product ratio. A more stable intermediate may not necessarily lead to the major product if the subsequent cyclization step has a higher activation energy.

Q3: My reaction is sluggish and gives low yields, in addition to poor regioselectivity. What should I do?

A3: Low yields and poor selectivity often go hand-in-hand. Addressing the yield issue can sometimes resolve the selectivity problem.

- **Catalyst Efficacy:** Ensure your acid catalyst is active and present in a sufficient amount. If using sulfuric acid, ensure it is concentrated. For PPA, ensure it is fresh and has not absorbed atmospheric moisture.
- **Dehydration:** The Combes synthesis involves the removal of water. If water is not effectively removed, the reaction equilibrium may not favor product formation. Using a more effective dehydrating agent like PPE can be beneficial.[1]
- **Reaction Time and Temperature:** Monitor your reaction by TLC to determine the optimal reaction time. Pushing the reaction for too long at high temperatures can lead to decomposition and side product formation.

Troubleshooting Guide

Symptom	Potential Cause	Suggested Solution
Poor regioselectivity (near 1:1 ratio)	- Similar steric and electronic environment at both carbonyls of the β -diketone. - Ineffective catalyst in differentiating between the two transition states.	- Modify Substrates: Introduce a bulky group on one side of the β -diketone or an electronically directing group on the aniline. - Change Catalyst: Switch from H_2SO_4 to Polyphosphoric Acid (PPA) or Polyphosphoric Ester (PPE).
Unexpected major regioisomer	- Misinterpretation of electronic directing effects. - Kinetic vs. thermodynamic control.	- Analyze Substituent Effects: Carefully consider the combined inductive and resonance effects of your substituents. - Optimize Temperature: Run the reaction at a lower temperature to favor the kinetically controlled product.
Low yield and formation of tar-like byproducts	- Harsh reaction conditions (e.g., high concentration of strong acid, high temperature). - Incomplete reaction or decomposition of starting materials/products.	- Milder Catalyst: Use PPE, which often allows for lower reaction temperatures. - Optimize Reaction Time: Monitor the reaction by TLC to avoid prolonged heating. - Slow Addition: Add the acid catalyst slowly to control the initial exotherm.
Reaction does not go to completion	- Insufficient catalyst activity. - Presence of water in the reaction mixture.	- Fresh Catalyst: Use freshly opened or properly stored acid catalysts. - Efficient Dehydration: Employ a more effective dehydrating agent like PPE.

Experimental Protocols

Protocol 1: General Combes Synthesis using Sulfuric Acid

- **Reactant Mixture:** In a round-bottom flask, combine the aniline (1.0 equiv.) and the β -diketone (1.0-1.2 equiv.).
- **Acid Addition:** Cool the mixture in an ice bath and slowly add concentrated sulfuric acid (2-4 equiv.) with vigorous stirring.
- **Reaction:** Heat the reaction mixture to the desired temperature (typically 80-120 °C) and monitor the progress by TLC.
- **Work-up:** After the reaction is complete, carefully pour the cooled reaction mixture onto crushed ice.
- **Neutralization and Isolation:** Neutralize the acidic solution with a suitable base (e.g., concentrated ammonia or sodium hydroxide solution) until the product precipitates. Collect the solid by filtration, wash with water, and dry. If the product is an oil, extract with a suitable organic solvent.
- **Purification:** Purify the crude product by recrystallization or column chromatography.

Protocol 2: High-Regioselectivity Combes Synthesis using Polyphosphoric Acid (PPA)

- **Reactant Mixture:** In a round-bottom flask equipped with a mechanical stirrer, combine the aniline (1.0 equiv.) and the β -diketone (1.0 equiv.).
- **PPA Addition:** Gently heat the polyphosphoric acid (PPA) to reduce its viscosity and add it to the reaction mixture (typically 10-20 times the weight of the aniline).
- **Reaction:** Heat the mixture with efficient stirring to the desired temperature (often in the range of 100-160 °C). Monitor the reaction progress by TLC.

- **Work-up:** After completion, cool the reaction mixture to about 80 °C and carefully pour it onto a stirred mixture of ice and water.
- **Neutralization and Isolation:** Neutralize the aqueous solution with a strong base (e.g., 50% NaOH solution) while cooling in an ice bath. The product will either precipitate and can be filtered, or it can be extracted with an organic solvent.
- **Purification:** Purify the crude product as described in Protocol 1.

Protocol 3: Preparation and Use of Polyphosphoric Ester (PPE) for Enhanced Regioselectivity

This protocol describes the in-situ preparation of PPE, which is often more effective than pre-prepared PPE.

- **PPE Preparation:** In a three-necked flask equipped with a mechanical stirrer, a thermometer, and a condenser, add polyphosphoric acid (PPA). Heat the PPA to approximately 70-80 °C and slowly add the desired alcohol (e.g., ethanol, 1-2 equiv. relative to the aniline) with vigorous stirring. Continue stirring at this temperature for 30-60 minutes to ensure the formation of the polyphosphoric ester.
- **Reactant Addition:** Cool the freshly prepared PPE to the desired reaction temperature (often lower than with PPA, e.g., 80-120 °C) and add the aniline (1.0 equiv.) followed by the β -diketone (1.0 equiv.).
- **Reaction:** Stir the mixture at the set temperature and monitor its progress by TLC.
- **Work-up and Purification:** Follow the work-up and purification steps as outlined in Protocol 2.

Mechanistic Insights: Visualizing the Regiochemical Fork

The regioselectivity in the Combes synthesis is determined by the relative stability of the transition states leading to the two possible regioisomers during the electrophilic aromatic substitution step. The following diagram illustrates the two competing cyclization pathways originating from the enamine intermediate.

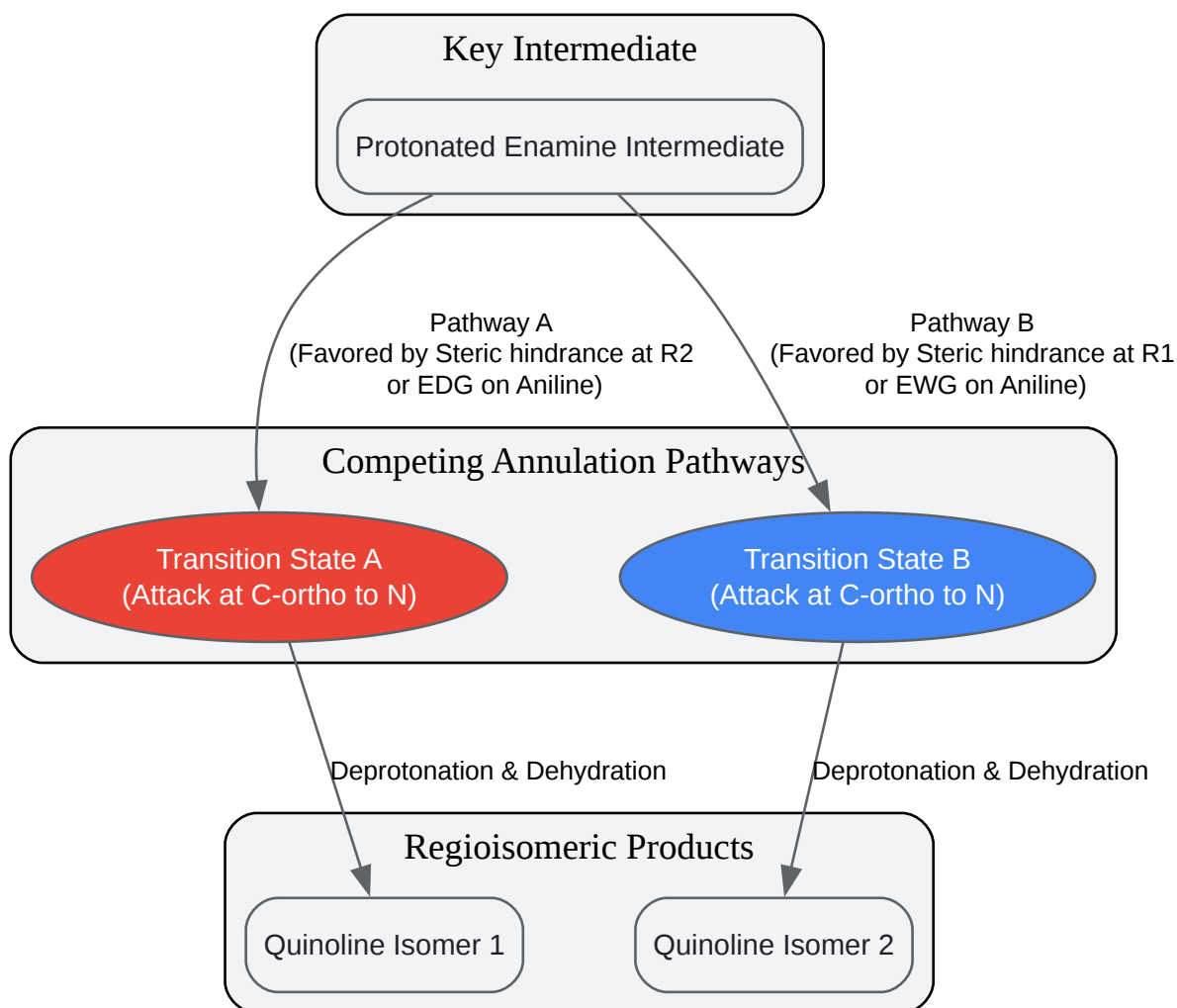

[Click to download full resolution via product page](#)

Need Custom Synthesis?

BenchChem offers custom synthesis for rare earth carbides and specific isotopic labeling.

Email: info@benchchem.com or [Request Quote Online](#).

Sources

- 1. [Combes quinoline synthesis - Wikipedia \[en.wikipedia.org\]](#)
- 2. [Combes Quinoline Synthesis \(Chapter 16\) - Name Reactions in Organic Synthesis \[cambridge.org\]](#)

- To cite this document: BenchChem. [Navigating the Combes Quinoline Synthesis: A Technical Guide to Overcoming Poor Regioselectivity]. BenchChem, [2026]. [Online PDF]. Available at: [<https://www.benchchem.com/product/b1520180/docs#navigating-the-combes-quinoline-synthesis-a-technical-guide-to-overcoming-poor-regioselectivity>]

Disclaimer & Data Validity:

The information provided in this document is for Research Use Only (RUO) and is strictly not intended for diagnostic or therapeutic procedures. While BenchChem strives to provide accurate protocols, we make no warranties, express or implied, regarding the fitness of this product for every specific experimental setup.

Technical Support: The protocols provided are for reference purposes. Unsure if this reagent suits your experiment?

Need Industrial/Bulk Grade? [Request Custom Synthesis Quote](#)

BenchChem

Our mission is to be the trusted global source of essential and advanced chemicals, empowering scientists and researchers to drive progress in science and industry.

Contact

Address: 3281 E Guasti Rd

Ontario, CA 91761, United States

Phone: (601) 213-4426

Email: info@benchchem.com

[Contact our Ph.D. Support Team for a compatibility check](#)