

Comparative Mass Spectrometry Guide: 4,6-Dimethyl-2-mercaptopyrimidine (DMMP)

Author: BenchChem Technical Support Team. **Date:** May 2026

Compound of Interest

Compound Name:	4,6-Dimethyl-2-mercaptopyrimidine
CAS No.:	131321-42-1
Cat. No.:	B152782

[Get Quote](#)

Executive Summary

4,6-Dimethyl-2-mercaptopyrimidine (DMMP) (CAS: 7686-20-6) is a critical heterocyclic building block in the synthesis of antiviral agents, antithyroid drugs, and functionalized ligands. For researchers in drug development, accurate structural characterization of DMMP—and distinguishing it from metabolic byproducts or impurities—is paramount.

This guide provides an in-depth technical analysis of the mass spectrometric (MS) behavior of DMMP. Unlike generic spectral lists, we compare its fragmentation mechanics against key structural analogs (2-Mercaptopyrimidine) and isosteres (4,6-Dimethyl-2-hydroxypyrimidine) to establish definitive identification criteria. We further evaluate the performance of Electron Impact (EI) versus Electrospray Ionization (ESI) for this specific compound.

Structural Context: The Thione-Thiol Tautomerism

Before analyzing fragmentation, one must understand the precursor state. DMMP exists in a tautomeric equilibrium between the thiol (mercapto) and thione forms.

- Solid/Solution State: Predominantly exists as the thione (4,6-dimethylpyrimidine-2(1H)-thione) due to the stability of the thioamide resonance.
- Gas Phase (MS): The ionization process can access both tautomers, but the thiol form often drives specific fragmentation pathways (e.g., loss of SH radical).

“

Critical Insight: In ESI-MS, the thione form favors protonation at the sulfur or ring nitrogen, yielding

. In EI-MS, the high energy (70 eV) accesses hard fragmentation channels independent of the initial solution equilibrium.

Fragmentation Analysis: The Product (DMMP)

Electron Impact (EI) Fingerprint

Under standard 70 eV EI conditions, DMMP exhibits a robust molecular ion, characteristic of aromatic heterocycles stabilized by methyl groups.

Key Spectral Peaks (Normalized):

m/z	Identity	Relative Intensity	Mechanism
140		100% (Base)	Stable molecular ion (C H N S).
142		~4.5%	Diagnostic S isotope peak.
141		~7.8%	C isotope contribution.
82		~60-80%	Diagnostic Fragment. Loss of isothiocyanate moiety.
67		~20-30%	Ring contraction/loss of methyl nitrile.
39		~40%	Cyclopropenyl cation (aromatic breakdown).

Mechanistic Pathway (The "NCS" Rule)

The most distinctive feature of DMMP fragmentation is the expulsion of a neutral NCS fragment (Mass 58). This pathway is energetically favored over simple methyl loss (

) due to the stability of the expelled neutral species and the resulting ring-contracted cation.

Diagram 1: Fragmentation Pathway of DMMP

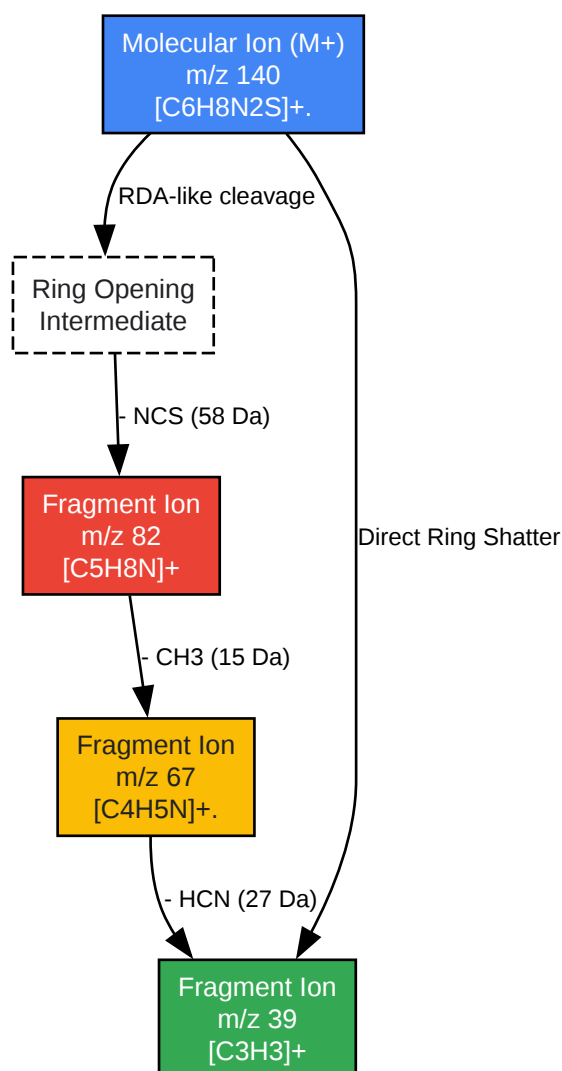

[Click to download full resolution via product page](#)

Caption: Proposed fragmentation tree for DMMP illustrating the dominant NCS loss pathway characteristic of 2-mercaptopyrimidines.

Comparative Analysis: DMMP vs. Alternatives

To validate the identity of DMMP, we compare its performance against its unmethylated parent and its oxygenated isostere.

DMMP vs. 2-Mercaptopyrimidine (2-MP)

Alternative: 2-Mercaptopyrimidine (CAS: 1450-85-7, MW 112). Comparison Logic: Assessing the stabilizing effect of methyl groups.

Feature	DMMP (Product)	2-MP (Alternative)	Analysis
Molecular Ion	m/z 140 (Very Stable)	m/z 112 (Stable)	Methyl groups in DMMP donate electron density, stabilizing the aromatic ring against total fragmentation.
Primary Loss	-58 (NCS) m/z 82	-27 (HCN) m/z 85	2-MP favors HCN loss because it lacks the steric bulk of methyls that promote the RDA-driven NCS expulsion seen in DMMP.
Base Peak	m/z 140	m/z 112	Both exhibit high stability, but DMMP's fragment ions are more structurally specific.

DMMP vs. 4,6-Dimethyl-2-hydroxypyrimidine (DMHP)

Alternative: 4,6-Dimethyl-2-hydroxypyrimidine (CAS: 108-79-2, MW 124). Comparison Logic: Differentiating Sulfur vs. Oxygen isosteres (common metabolic switch).

Feature	DMMP (Sulfur)	DMHP (Oxygen)	Analysis
Isotope Pattern	Distinct M+2 (~4.4%)	Negligible M+2	The S isotope is a definitive marker for DMMP. DMHP lacks this, making DMMP easier to identify in complex mixtures.
Fragmentation	Loss of NCS (58 Da)	Loss of HNCO (43 Da)	The C=S bond is weaker than C=O. DMHP loses the isocyanate moiety (43 Da) to form m/z 81, whereas DMMP loses isothiocyanate (58 Da) to form m/z 82.

Technique Comparison: EI vs. ESI

For drug development workflows, choosing the right ionization mode is critical.

Parameter	Electron Impact (EI)	Electrospray Ionization (ESI)	Recommendation
Ion Type	Radical Cation ()	Protonated Pseudomolecular Ion ()	Use ESI for pharmacokinetic (PK) quantification; use EI for impurity identification.
Fragmentation	Hard, reproducible, library-searchable.	Soft, minimal fragmentation without CID (Collision Induced Dissociation).	EI is superior for structural confirmation.
Sensitivity	Moderate (nanogram range).	High (picogram range).	ESI is required for trace metabolite detection in plasma.
Solvent Compatibility	Requires volatile solvents (GC).	Compatible with MeOH/Water/ACN (LC).	DMMP is soluble in polar organic solvents, favoring LC-MS (ESI) for bioanalysis.

Experimental Protocols

Sample Preparation (Self-Validating)

- Solvent: Methanol (HPLC Grade). Reason: DMMP has poor solubility in non-polar solvents; Methanol ensures complete dissolution of the thione form.
- Concentration: 10 µg/mL for direct infusion (ESI); 100 µg/mL for GC-MS (EI).
- Validation Step: Check for the presence of the dimer peak (

at m/z 281 in ESI). If the dimer >50% of the monomer, dilute the sample to prevent source saturation.

Instrumental Workflow

Diagram 2: Analytical Workflow

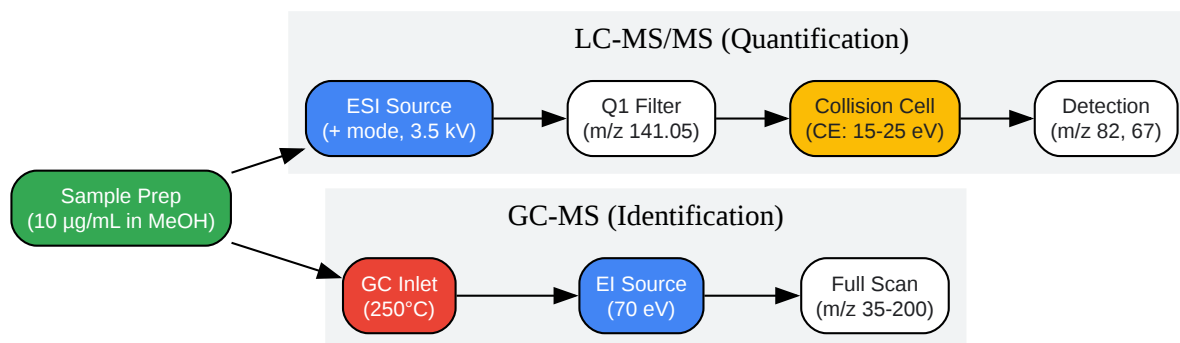

[Click to download full resolution via product page](#)

Caption: Dual-stream workflow for DMMP analysis. ESI path for sensitivity/quantification; EI path for structural confirmation.

References

- National Institute of Standards and Technology (NIST). **4,6-Dimethyl-2-mercaptopyrimidine** Mass Spectrum (EI). NIST Mass Spectrometry Data Center.[1]
- PubChem. **4,6-Dimethyl-2-mercaptopyrimidine** (Compound Summary). National Library of Medicine.
- Salem, M. A., et al. (2014). "Mass Spectral Fragmentation Modes of Some New Pyrimidinethiones." International Journal of Materials and Chemistry. (Discussion of NCS loss mechanism in mercaptopyrimidines).
- Creative Proteomics. Electrospray Ionization (ESI) vs Electron Impact (EI) in Heterocycle Analysis.

Need Custom Synthesis?

BenchChem offers custom synthesis for rare earth carbides and specific isotopic labeling.

Email: info@benchchem.com or [Request Quote Online](#).

Sources

- [1. 4,6-Dimethyl-2-mercaptopyrimidine | C6H8N2S | CID 673664 - PubChem \[pubchem.ncbi.nlm.nih.gov\]](#)
- To cite this document: BenchChem. [Comparative Mass Spectrometry Guide: 4,6-Dimethyl-2-mercaptopyrimidine (DMMP)]. BenchChem, [2026]. [Online PDF]. Available at: [\[https://www.benchchem.com/product/b152782/docs#comparative-mass-spectrometry-guide-4-6-dimethyl-2-mercaptopyrimidine-dmmp\]](https://www.benchchem.com/product/b152782/docs#comparative-mass-spectrometry-guide-4-6-dimethyl-2-mercaptopyrimidine-dmmp)

Disclaimer & Data Validity:

The information provided in this document is for Research Use Only (RUO) and is strictly not intended for diagnostic or therapeutic procedures. While BenchChem strives to provide accurate protocols, we make no warranties, express or implied, regarding the fitness of this product for every specific experimental setup.

Technical Support: The protocols provided are for reference purposes. Unsure if this reagent suits your experiment?

Need Industrial/Bulk Grade? [Request Custom Synthesis Quote](#)

BenchChem

Our mission is to be the trusted global source of essential and advanced chemicals, empowering scientists and researchers to drive progress in science and industry.

Contact

Address: 3281 E Guasti Rd
Ontario, CA 91761, United States
Phone: (601) 213-4426
Email: info@benchchem.com

[Contact our Ph.D. Support Team for a compatibility check](#)

