

Application Note: Grignard Formation from (2-Bromo-6-chlorophenyl)trimethylsilane

Author: BenchChem Technical Support Team. **Date:** May 2026

Compound of Interest

Compound Name: (2-Bromo-6-chlorophenyl)trimethylsilane

Cat. No.: B15198908

[Get Quote](#)

Executive Summary

The formation of Grignard reagents from **(2-Bromo-6-chlorophenyl)trimethylsilane** presents a unique synthetic challenge due to the extreme steric congestion imposed by the ortho-trimethylsilyl (TMS) group and the requirement for chemoselectivity (Br vs. Cl).

Traditional direct insertion (Mg metal) is strongly discouraged for this substrate due to:

- **Kinetic Inhibition:** The bulky TMS group effectively shields the C-Br bond, preventing the close contact with the magnesium lattice required for oxidative addition.
- **Thermal Instability:** Forcing conditions (reflux) required to overcome this barrier often lead to Wurtz coupling or desilylation.
- **Chemoselectivity Risks:** High temperatures compromise the selectivity between the C-Br and C-Cl bonds.

Recommended Approach: This protocol utilizes Magnesium-Halogen Exchange using the "Turbo Grignard" reagent (iPrMgCl·LiCl).[1] This method proceeds under mild conditions (-15

°C to 0 °C), ensuring complete conversion, exclusive regioselectivity for the bromide, and preservation of the silyl group.

Mechanistic Insight & Reaction Design

The Steric Challenge

The substrate features a 1,2,3-substitution pattern (if TMS=1, Br=2, Cl=6, the Br is flanked by TMS and H; actually, C2-Br is ortho to C1-TMS). The Van der Waals radius of the TMS group creates a "steric wall," making the C-Br bond difficult for heterogeneous solid-liquid reactions (Mg turnings) to access.

The Solution: Turbo Grignard Exchange

The Knochel-Hauser Turbo Grignard (iPrMgCl·LiCl) overcomes these limitations via a homogeneous mechanism:

- Solubility: The LiCl additive breaks up polymeric Grignard aggregates, creating highly reactive monomeric species.
- Thermodynamics: The exchange is driven by the formation of a more stable sp²-hybridized aryl Grignard from a less stable sp³-hybridized alkyl Grignard (isopropyl).
- Selectivity: The exchange rate for Aryl-Br is orders of magnitude faster than Aryl-Cl at temperatures below 0 °C, ensuring the chloride remains intact.

Reaction Pathway Diagram (DOT)

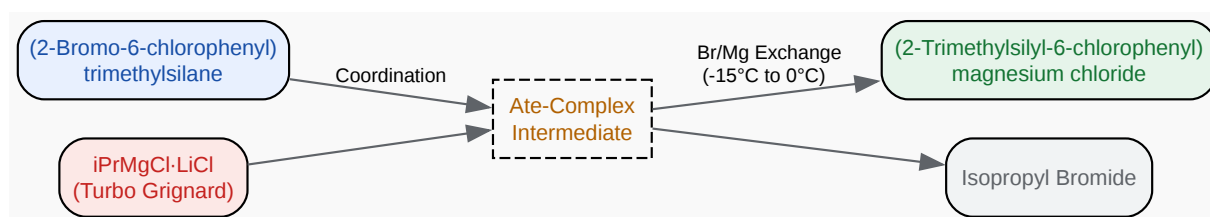

[Click to download full resolution via product page](#)

Figure 1: Mechanistic pathway for the Mg-Halogen exchange. The LiCl additive facilitates the formation of a reactive magnesiate intermediate, driving the equilibrium toward the stabilized

aryl Grignard.

Experimental Protocol

Materials & Equipment

- Substrate: **(2-Bromo-6-chlorophenyl)trimethylsilane** (High purity, >98%).
- Reagent: **iPrMgCl·LiCl** complex solution (approx. 1.3 M in THF). Note: Titrate before use.
- Solvent: Anhydrous THF (distilled over Na/Benzophenone or from SPS).
- Glassware: Flame-dried Schlenk flask (25 mL or 50 mL), magnetic stir bar, rubber septa, Ar/N₂ balloon or manifold.

Step-by-Step Procedure

Phase 1: Setup and Dehydration

- Flame Dry: Flame-dry a 2-neck round bottom flask equipped with a magnetic stir bar under vacuum. Backfill with dry Argon. Repeat 3 times.
- Charge Substrate: Add **(2-Bromo-6-chlorophenyl)trimethylsilane** (1.0 equiv, e.g., 500 mg) to the flask.
- Solvation: Add anhydrous THF to achieve a concentration of 0.5 M (approx. 3.8 mL for 500 mg). Stir until fully dissolved.
- Temperature Control: Cool the solution to -15 °C using an ice/salt bath or cryocooler. Crucial: Do not cool to -78 °C; the exchange kinetics are too slow for this sterically hindered substrate.

Phase 2: The Exchange Reaction

- Dropwise Addition: Slowly add **iPrMgCl·LiCl** (1.1 equiv) dropwise via syringe over 5-10 minutes.
 - Observation: No significant exotherm should be observed due to the scale and rate, but color change (light yellow to amber) is common.

- Incubation: Allow the reaction to stir at $-15\text{ }^{\circ}\text{C}$ for 30 minutes, then slowly warm to $0\text{ }^{\circ}\text{C}$ and stir for an additional 1-2 hours.
 - Why: The steric bulk of the TMS group imposes a high activation energy barrier. Warming to $0\text{ }^{\circ}\text{C}$ ensures conversion without risking benzyne elimination (which is unlikely here due to the meta-chloro position relative to the Mg, but general caution applies).

Phase 3: Monitoring & Titration

- GC/MS Aliquot: Withdraw $50\text{ }\mu\text{L}$ of reaction mixture and quench into a vial containing saturated $\text{NH}_4\text{Cl}/\text{EtOAc}$.
 - Success Criteria: GC-MS should show the disappearance of the starting bromide and the appearance of the des-bromo product (2-chlorophenyltrimethylsilane).
 - Note: If starting material remains ($>5\%$), stir for an additional hour at $0\text{ }^{\circ}\text{C}$.

Phase 4: Utilization

- Use: The resulting Grignard solution is stable at $0\text{ }^{\circ}\text{C}$ for several hours. Use immediately for subsequent electrophilic trapping (e.g., addition to aldehydes, ketones, or cross-coupling).

Experimental Workflow Diagram (DOT)

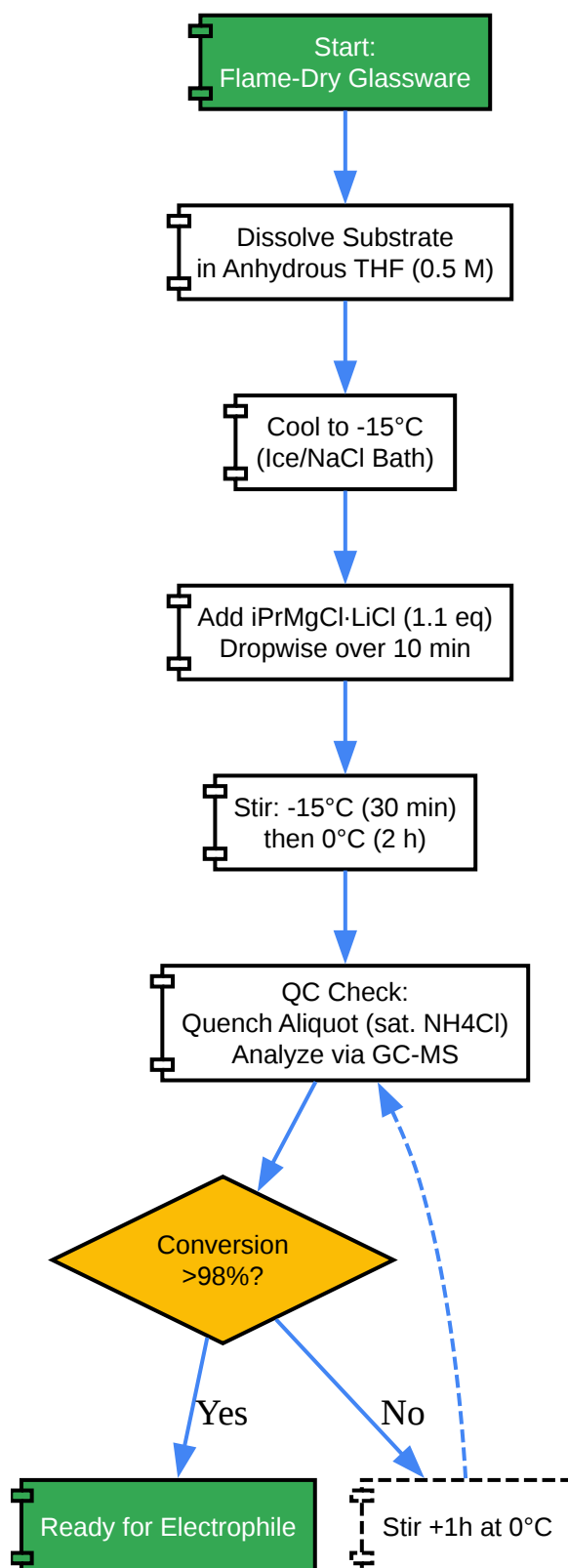

[Click to download full resolution via product page](#)

Figure 2: Operational workflow for the preparation of the Grignard reagent.

Data Specifications & Troubleshooting

Quantitative Parameters

Parameter	Specification	Rationale
Concentration	0.5 M - 0.8 M	High dilution slows exchange; too concentrated risks precipitation.
Temperature	-15 °C to 0 °C	Balances exchange rate (slow due to sterics) vs. stability.
Stoichiometry	1.05 - 1.10 equiv (iPrMgCl)	Slight excess ensures full consumption of the bromide.
Time	2 - 4 Hours	Steric hindrance of TMS group significantly slows kinetics.

Troubleshooting Guide

- Problem: GC-MS shows only starting material.
 - Cause: Water in THF or degraded Turbo Grignard reagent.
 - Fix: Titrate iPrMgCl·LiCl using Iodine or Menthol/Phenanthroline method before use. Ensure THF is <50 ppm water.
- Problem: Formation of "Wurtz-type" homocoupling dimers.
 - Cause: Temperature too high during addition.
 - Fix: Strictly maintain -15 °C during the initial addition of the exchange reagent.
- Problem: Loss of TMS group.
 - Cause: Not observed under these conditions. If seen, check for presence of Fluoride contamination or extreme basicity (unlikely with Mg).

References

- Knochel, P., et al. "Functionalized Grignard Reagents via Magnesium-Halogen Exchange." *Angewandte Chemie International Edition*, vol. 42, no. 36, 2003, pp. 4302-4320.
- Krasovskiy, A., & Knochel, P. "A LiCl-Mediated Br/Mg Exchange Reaction for the Preparation of Functionalized Aryl- and Heteroarylmagnesium Compounds." *Angewandte Chemie International Edition*, vol. 43, no. 25, 2004, pp. 3333-3336.
- Bao, R. L.-Y., et al. "Scope and Mechanism of the Magnesium-Halogen Exchange." *Journal of the American Chemical Society*, vol. 136, no. 2, 2014. (Context on steric effects in exchange reactions).

Need Custom Synthesis?

BenchChem offers custom synthesis for rare earth carbides and specific isotopic labeling.

Email: info@benchchem.com or [Request Quote Online](#).

Sources

- [1. rsc.org \[rsc.org\]](https://www.rsc.org)
- To cite this document: BenchChem. [Application Note: Grignard Formation from (2-Bromo-6-chlorophenyl)trimethylsilane]. BenchChem, [2026]. [Online PDF]. Available at: [\[https://www.benchchem.com/product/b15198908/docs#application-note-grignard-formation-from-2-bromo-6-chlorophenyl-trimethylsilane\]](https://www.benchchem.com/product/b15198908/docs#application-note-grignard-formation-from-2-bromo-6-chlorophenyl-trimethylsilane)

Disclaimer & Data Validity:

The information provided in this document is for Research Use Only (RUO) and is strictly not intended for diagnostic or therapeutic procedures. While BenchChem strives to provide accurate protocols, we make no warranties, express or implied, regarding the fitness of this product for every specific experimental setup.

Technical Support: The protocols provided are for reference purposes. Unsure if this reagent suits your experiment?

Need Industrial/Bulk Grade? [Request Custom Synthesis Quote](#)

BenchChem

Our mission is to be the trusted global source of essential and advanced chemicals, empowering scientists and researchers to drive progress in science and industry.

Contact

Address: 3281 E Guasti Rd

Ontario, CA 91761, United States

Phone: (601) 213-4426

Email: info@benchchem.com

[Contact our Ph.D. Support Team for a compatibility check](#)