

A Comparative Guide to the Herbicidal Activity of Pyrazole Carboxamides

Author: BenchChem Technical Support Team. **Date:** May 2026

Compound of Interest

Compound Name: *Ethyl 1-(3-bromobenzyl)-1H-pyrazole-4-carboxylate*

CAS No.: 1197233-82-1

Cat. No.: B1519367

[Get Quote](#)

For Researchers, Scientists, and Agrochemical Development Professionals

Introduction: The Rise of Pyrazole Carboxamides in Weed Management

In the continuous effort to develop more effective and selective herbicides, the pyrazole carboxamide class of compounds has emerged as a significant and potent tool in modern agriculture. Initially recognized for their fungicidal properties, their herbicidal potential has been increasingly explored and commercialized. These compounds offer a distinct mode of action, providing an essential resource for managing weed resistance to other established herbicide classes. This guide provides an in-depth comparison of the herbicidal activity of pyrazole carboxamides, delving into their mechanism of action, structure-activity relationships, and performance against other herbicide alternatives, supported by experimental data and detailed protocols.

Mechanism of Action: Targeting the Powerhouse of the Cell

The primary herbicidal mode of action for the majority of pyrazole carboxamides is the inhibition of the enzyme succinate dehydrogenase (SDH), also known as Complex II, in the mitochondrial electron transport chain.^{[1][2]} This enzyme is a crucial component of cellular respiration, responsible for the oxidation of succinate to fumarate. By binding to the ubiquinone-binding site of the SDH enzyme, pyrazole carboxamide herbicides effectively block the electron flow, leading to a cascade of detrimental effects.^{[1][3]} This disruption of cellular energy production ultimately results in the cessation of growth and death of susceptible plants.

The inhibition of SDH is a well-established mechanism, and the specificity of different pyrazole carboxamide structures for the enzyme's binding pocket is a key determinant of their herbicidal potency and selectivity.^[3]

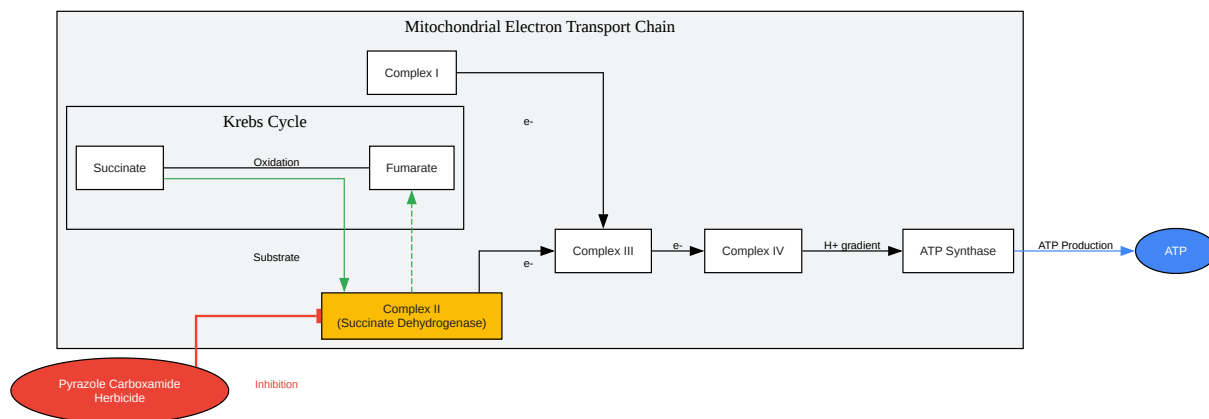

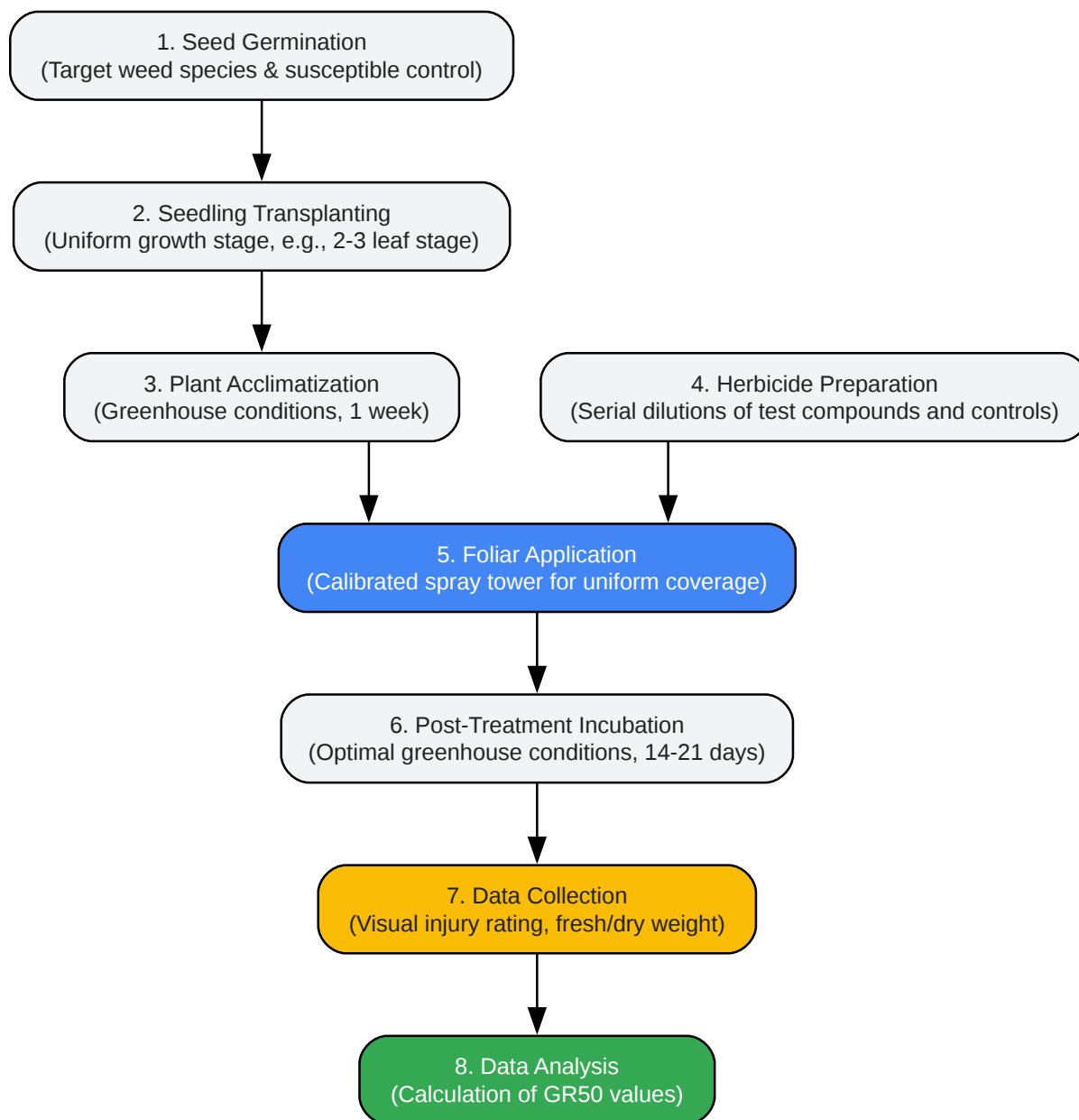

[Click to download full resolution via product page](#)

Workflow of a Whole-Plant Post-Emergence Greenhouse Bioassay.

Detailed Steps:

- Plant Material and Growth Conditions:
 - Seed Selection: Utilize certified seeds of the target weed species (e.g., *Amaranthus retroflexus*, *Setaria viridis*) and a known susceptible control population.

- Germination: Germinate seeds in petri dishes on moist filter paper or in trays with a sterile potting mix.
- Transplanting: Once seedlings reach a uniform growth stage (e.g., 2-3 true leaves), transplant them into individual pots (e.g., 10 cm diameter) filled with a standardized greenhouse potting medium. [4][5] * Acclimatization: Allow the transplanted seedlings to acclimatize in the greenhouse for approximately one week under controlled conditions (e.g., 25/18°C day/night temperature, 16-hour photoperiod) before herbicide application. Ensure plants are well-watered but not waterlogged. [5]
- Herbicide Preparation and Application:
 - Stock Solutions: Prepare stock solutions of the pyrazole carboxamide test compounds and reference herbicides (e.g., a commercial ALS inhibitor) in an appropriate solvent (e.g., acetone with a surfactant like Tween 20).
 - Serial Dilutions: Perform serial dilutions of the stock solutions with distilled water to create a range of at least six concentrations to generate a dose-response curve. Include a negative control (solvent and water only).
 - Application: Use a calibrated laboratory spray tower equipped with a flat-fan nozzle to apply the herbicide solutions uniformly to the plant foliage. The application volume should be consistent across all treatments (e.g., 200 L/ha). [5]
- Post-Treatment Evaluation and Data Analysis:
 - Incubation: After treatment, return the plants to the greenhouse and arrange them in a randomized complete block design. Maintain optimal growing conditions for 14 to 21 days. [5] * Data Collection:
 - Visual Injury Rating: At 7, 14, and 21 days after treatment (DAT), visually assess each plant for phytotoxicity symptoms (e.g., chlorosis, necrosis, stunting) on a scale of 0% (no effect) to 100% (complete death).
 - Biomass Measurement: At 21 DAT, harvest the above-ground biomass of each plant. Record the fresh weight, and then dry the biomass in an oven at 70°C for 72 hours to determine the dry weight. [5] * Data Analysis:

- Calculate the percent growth reduction relative to the negative control for both fresh and dry weight data.
- Use a statistical software package to perform a non-linear regression analysis (e.g., a four-parameter log-logistic model) to fit the dose-response data and calculate the GR50 value for each herbicide.

Conclusion and Future Outlook

Pyrazole carboxamide herbicides represent a valuable class of active ingredients in modern weed management strategies, primarily due to their effective inhibition of succinate dehydrogenase. Their unique mode of action makes them particularly useful for controlling weeds that have developed resistance to other herbicide classes. The structure-activity relationship studies continue to guide the synthesis of new derivatives with improved efficacy and selectivity.

Future research will likely focus on the development of novel pyrazole carboxamides with a broader weed control spectrum, enhanced crop safety, and a lower environmental impact. Furthermore, understanding and managing the potential for weed resistance to SDHI herbicides will be critical for their long-term sustainability in agriculture. The integration of these compounds into comprehensive integrated weed management programs will be key to maximizing their benefits while minimizing the risks of resistance development.

References

- BenchChem. (2025).
- Ishikawa, T., et al. (n.d.).
- Li, C., et al. (2024). Design, Synthesis, and Herbicidal Activity Study of Novel Pyrazole-Carboxamides as Potential Transketolase Inhibitors. *Journal of Agricultural and Food Chemistry*.
- BenchChem. (2025). Application Notes and Protocols for Greenhouse Bioassay of Siduron Herbicide Activity. BenchChem.
- Koike, J., et al. (n.d.).
- Li, Y., et al. (2025). Advances in Pyrazole as an Active Fragment for Herbicide Discovery. *Journal of Agricultural and Food Chemistry*.
- Li, C., et al. (2024). Design, Synthesis, and Herbicidal Activity Study of Novel Pyrazole-Carboxamides as Potential Transketolase Inhibitors. Semantic Scholar.
- NC State Extension. (2016). Conducting a Bioassay For Herbicide Residues.

- Joe Gardener. (2021). How to Conduct a Bioassay Test | Check for Herbicides. joegardener.com.
- Paule, J., et al. (2023). Inhibition of Succinate Dehydrogenase by Pesticides (SDHIs) and Energy Metabolism.
- Avenot, H. F., & Michailides, T. J. (2010). 24 SDH-Inhibitors: History, Biological Performance and Molecular Mode of Action.
- Burgos, N. R., & Tranel, P. J. (2014). Whole-Plant and Seed Bioassays for Resistance Confirmation. Cambridge University Press & Assessment.
- Paule, J., et al. (2023). Inhibition of Succinate Dehydrogenase by Pesticides (SDHIs) and Energy Metabolism.
- Paule, J., et al. (2023). Inhibition of Succinate Dehydrogenase by Pesticides (SDHIs) and Energy Metabolism. MDPI.
- Avenot, H. F., & Michailides, T. J. (2015). Succinate dehydrogenase inhibitor fungicides and the modifications on the bridge.
- BenchChem. (2025). A Comparative Analysis of Foramsulfuron and Other ALS Inhibitors in Weed Management. BenchChem.
- Le Corre, V., et al. (2019). Dose response experiment of the *Amaranthus retroflexus* Quebec biotype...
- Gazolla, A., et al. (2015). Dose-response curve to soil applied herbicides and susceptibility evaluation of different amaranthus species using model identity. SciELO.
- Mikulka, J., et al. (2021). Fitted logarithmic dose–response curves for *A. retroflexus* (a) with terbuthylazine and (b) with metamilon. S: susceptible biotype.
- Kumar, V., et al. (2020). Differential sensitivity of Kansas Palmer amaranth populations to multiple herbicides. Wiley Online Library.
- Woznica, Z., & Stankiewicz-Kosyl, M. (2024). Impact of novel herbicide based on synthetic auxins and ALS inhibitor on weed control. Scientific Reports.
- Principles of Weed Control. (n.d.). 16.
- Chauhan, B. S., & Johnson, D. E. (2009). Efficacy Comparison of Some New Natural-Product Herbicides for Weed Control at Two Growth Stages.
- Boe, J. (2020). Establishing the Value of ALS-Inhibiting Herbicides in Fields with Con. University of Nebraska - Lincoln.
- Gazolla, A., et al. (2011). Dose-response curves of biotypes of redroot pigweed (*A. retroflexus*)...

Need Custom Synthesis?

BenchChem offers custom synthesis for rare earth carbides and specific isotopic labeling.

Email: info@benchchem.com or [Request Quote Online](#).

Sources

- [1. Inhibition of Succinate Dehydrogenase by Pesticides \(SDHIs\) and Energy Metabolism - PMC \[pmc.ncbi.nlm.nih.gov\]](#)
- [2. Inhibition of Succinate Dehydrogenase by Pesticides \(SDHIs\) and Energy Metabolism - PubMed \[pubmed.ncbi.nlm.nih.gov\]](#)
- [3. cabidigitallibrary.org \[cabidigitallibrary.org\]](#)
- [4. Step-By-Step Guide for Conducting a Bioassay to Assess Herbicide Carryover Risk | Wheat & Small Grains | Washington State University \[smallgrains.wsu.edu\]](#)
- [5. pdf.benchchem.com \[pdf.benchchem.com\]](#)
- To cite this document: BenchChem. [A Comparative Guide to the Herbicidal Activity of Pyrazole Carboxamides]. BenchChem, [2026]. [Online PDF]. Available at: [\[https://www.benchchem.com/product/b1519367/docs#a-comparative-guide-to-the-herbicidal-activity-of-pyrazole-carboxamides\]](https://www.benchchem.com/product/b1519367/docs#a-comparative-guide-to-the-herbicidal-activity-of-pyrazole-carboxamides)

Disclaimer & Data Validity:

The information provided in this document is for Research Use Only (RUO) and is strictly not intended for diagnostic or therapeutic procedures. While BenchChem strives to provide accurate protocols, we make no warranties, express or implied, regarding the fitness of this product for every specific experimental setup.

Technical Support: The protocols provided are for reference purposes. Unsure if this reagent suits your experiment?

Need Industrial/Bulk Grade? [Request Custom Synthesis Quote](#)

BenchChem

Our mission is to be the trusted global source of essential and advanced chemicals, empowering scientists and researchers to drive progress in science and industry.

Contact

Address: 3281 E Guasti Rd
Ontario, CA 91761, United States
Phone: (601) 213-4426
Email: info@benchchem.com

Contact our Ph.D. Support Team for a compatibility check