

Technical Support Center: Resolving Ambiguous NMR Spectra of Polysubstituted Benzofurans

Author: BenchChem Technical Support Team. **Date:** May 2026

Compound of Interest

Compound Name: 5-Benzofuranol, 2,4,6,7-tetramethyl-

CAS No.: 85979-45-9

Cat. No.: B15186068

[Get Quote](#)

Welcome to the technical support center dedicated to assisting researchers, scientists, and drug development professionals in navigating the complexities of Nuclear Magnetic Resonance (NMR) spectroscopy for the structural elucidation of polysubstituted benzofurans. The inherent structural diversity and electronic complexity of these scaffolds often lead to ambiguous NMR spectra, characterized by signal overlap and challenging peak assignments. This guide provides practical, in-depth troubleshooting strategies and frequently asked questions (FAQs) to empower you to confidently resolve these ambiguities and accelerate your research.

I. Understanding the Challenge: Why are Polysubstituted Benzofuran NMR Spectra Often Ambiguous?

The core challenge in interpreting the NMR spectra of polysubstituted benzofurans stems from the electronic nature of the heterocyclic ring system and the influence of various substituents. Protons on the benzene ring typically resonate in a narrow chemical shift range (approximately 6.5-8.0 ppm), leading to significant signal overlap, especially with increasing substitution.[1]

This overlap can obscure crucial coupling information, making it difficult to definitively assign the substitution pattern. Furthermore, the electronic effects of substituents can perturb the chemical shifts of both proton and carbon atoms in unpredictable ways, further complicating spectral interpretation.

II. Troubleshooting Guide & FAQs

This section is structured in a question-and-answer format to directly address common issues encountered during the NMR analysis of polysubstituted benzofurans.

FAQ 1: My ^1H NMR spectrum shows a complex, overlapping multiplet in the aromatic region. How can I begin to deconvolute these signals?

Answer:

This is the most common challenge. A standard ^1H NMR is often insufficient for complete assignment. The first and most crucial step is to employ two-dimensional (2D) NMR techniques to disperse the signals into a second dimension, revealing correlations that are hidden in the 1D spectrum.

Recommended Workflow:

- ^1H - ^1H COSY (Correlation Spectroscopy): This experiment is the workhorse for identifying proton-proton coupling networks.^[2] It will allow you to trace the connectivity of adjacent protons on the aromatic ring. For example, in a disubstituted benzene ring, you can "walk" around the ring from one proton to its neighbor.
- Data Interpretation: In the COSY spectrum, cross-peaks indicate that two protons are coupled. By identifying these correlations, you can piece together the fragments of your spin system.

Experimental Protocol: Acquiring a Standard ^1H - ^1H COSY Spectrum

A typical pulse program for a COSY experiment is `cosygpqf`. The following are general acquisition parameters that can be adapted to your specific instrument and sample:

Parameter	Value	Rationale
Pulse Program	cosygppqf	Standard gradient-selected COSY for clean spectra.
Spectral Width (F2 & F1)	~12 ppm	Should encompass all proton signals.
Number of Points (F2)	2048 (2K)	Provides adequate digital resolution in the direct dimension.
Number of Increments (F1)	256-512	Determines the resolution in the indirect dimension. More increments lead to better resolution but longer experiment times.
Number of Scans (ns)	4-16	Depends on sample concentration.
Relaxation Delay (d1)	1-2 s	Allows for relaxation of the spins between scans.

Logical Workflow for COSY Analysis:



[Click to download full resolution via product page](#)

Caption: Workflow for initial deconvolution of overlapping proton signals using ^1H - ^1H COSY.

FAQ 2: I have identified the proton spin systems using COSY, but I still cannot determine the substitution pattern. What is the next step?

Answer:

Once you have established the proton connectivity, the next step is to link these proton fragments to the carbon skeleton of the molecule. This is achieved through heteronuclear correlation experiments that reveal one-bond and multiple-bond correlations between protons and carbons.

Recommended Experiments:

- ^1H - ^{13}C HSQC (Heteronuclear Single Quantum Coherence): This experiment correlates each proton with the carbon atom to which it is directly attached (one-bond ^1JCH coupling).^{[3][4]} This is invaluable for assigning the chemical shifts of protonated carbons. An edited HSQC can further distinguish between CH, CH₂, and CH₃ groups by their phase.^[5]
- ^1H - ^{13}C HMBC (Heteronuclear Multiple Bond Correlation): This is arguably the most powerful experiment for determining the overall carbon framework and substitution pattern.^{[3][5]} It reveals correlations between protons and carbons that are two or three bonds away (^2JCH and ^3JCH). These long-range correlations act as bridges, connecting different spin fragments and linking them to quaternary (non-protonated) carbons.

Experimental Protocol: Acquiring ^1H - ^{13}C HSQC and HMBC Spectra

Parameter	HSQC (hsqcedetgpsisp2.2)	HMBC (hmbcgp1pndqf)	Rationale
¹ H Spectral Width (F2)	~12 ppm	~12 ppm	Encompass all proton signals.
¹³ C Spectral Width (F1)	~200 ppm	~200 ppm	Cover the full range of carbon chemical shifts.
¹ JCH (for HSQC)	~145 Hz	N/A	Average one-bond C-H coupling constant.
nJCH (for HMBC)	N/A	8 Hz	Optimized for long-range couplings. An additional experiment with 4 Hz can be beneficial.
Number of Increments (F1)	256	512	HMBC often requires higher resolution in the indirect dimension.
Number of Scans (ns)	2-8	8-32	HMBC is less sensitive and typically requires more scans.

Logical Workflow for Structure Elucidation using 2D NMR:

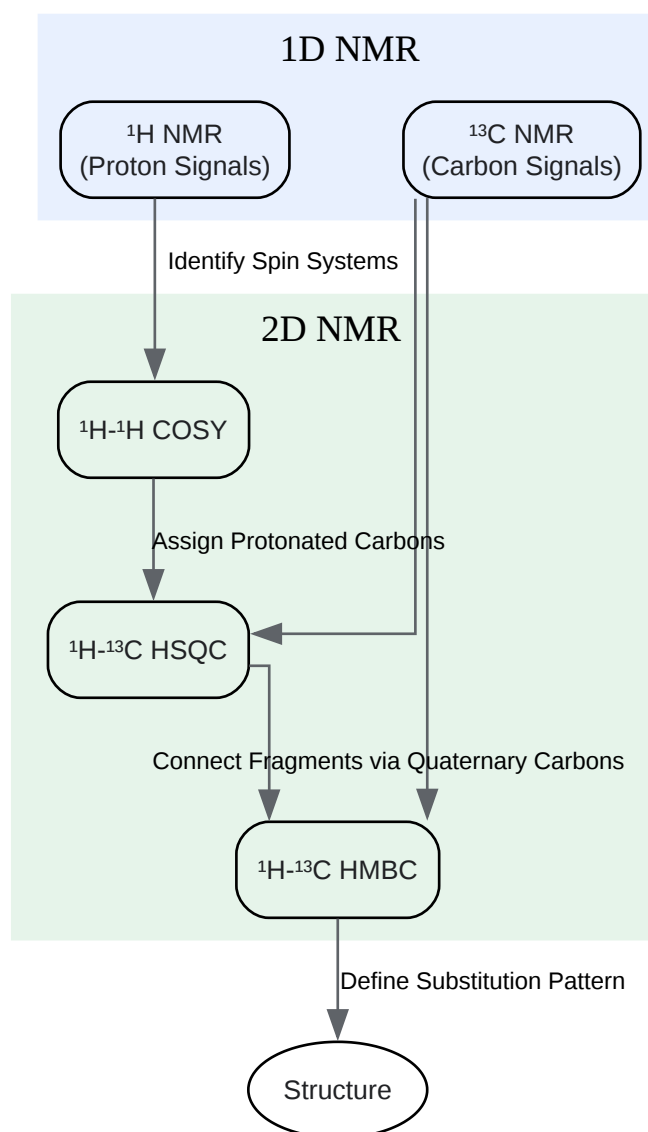

[Click to download full resolution via product page](#)

Caption: Integrated workflow for structure elucidation using 1D and 2D NMR experiments.

FAQ 3: Even with 2D NMR data, I have two possible regioisomers that are consistent with the COSY, HSQC, and HMBC data. How can I differentiate between them?

Answer:

This is a common scenario where through-bond correlations are insufficient to distinguish between isomers. In such cases, you need to probe through-space proximity using the Nuclear

Overhauser Effect (NOE).

Recommended Experiment:

- 1D NOE Difference or 2D NOESY (Nuclear Overhauser Effect Spectroscopy): The NOE is a phenomenon where saturating one proton with a radiofrequency pulse leads to an intensity change in the signals of other protons that are close in space (typically $< 5 \text{ \AA}$), regardless of whether they are directly bonded.^{[6][7]} By selectively irradiating a specific proton (e.g., a substituent methyl group or a specific aromatic proton) and observing which other protons show an enhancement, you can determine the spatial arrangement of the substituents. A 2D NOESY experiment provides all NOE correlations in a single spectrum.^{[7][8]}

Example Application:

Consider a benzofuran with a methyl group and a bromine atom on the benzene ring. If irradiation of the methyl protons results in an NOE enhancement of a specific aromatic proton, it confirms that this proton is spatially close to the methyl group, thus defining the substitution pattern.

FAQ 4: I have exhausted all experimental NMR techniques and still face ambiguity. Are there any other approaches?

Answer:

Yes. When experimental data is insufficient, computational chemistry can be a powerful tool to resolve ambiguities.^[9]

Recommended Approach:

- Density Functional Theory (DFT) Calculations: You can perform DFT calculations to predict the ^1H and ^{13}C NMR chemical shifts for all your proposed isomeric structures.^{[10][11]} The calculated chemical shifts are then compared to the experimental values. The isomer whose calculated spectrum most closely matches the experimental spectrum is the most likely correct structure. Several studies have demonstrated the utility of this approach for complex organic molecules.^[12]

Key Considerations for DFT Calculations:

- **Choice of Functional and Basis Set:** The accuracy of the calculated chemical shifts is highly dependent on the level of theory used. Common combinations like B3LYP/6-311+G(2d,p) or ω B97XD/aug-cc-pVDZ often provide a good balance of accuracy and computational cost.[9] [13]
- **Solvent Effects:** It is crucial to include a solvent model in the calculations (e.g., IEFPCM) that matches the solvent used for your NMR experiments, as solvent can significantly influence chemical shifts.[11]
- **Conformational Searching:** For flexible molecules, it is important to perform a conformational search and calculate the NMR parameters for the lowest energy conformers, then average them based on their Boltzmann populations.

Quantitative Comparison:

The agreement between calculated and experimental chemical shifts can be quantified using the Mean Absolute Error (MAE). The isomer with the lowest MAE is the most probable structure.

Isomer	Calculated ^{13}C MAE (ppm)	Calculated ^1H MAE (ppm)	Conclusion
Isomer A	5.8	0.45	Poor Agreement
Isomer B	1.9	0.15	Excellent Agreement - Likely Correct Structure

III. Summary of Troubleshooting Strategies

Issue	Recommended Action	Rationale
Overlapping Aromatic Signals	Run a ^1H - ^1H COSY experiment.	To identify proton-proton coupling networks and define spin systems.
Unknown Substitution Pattern	Acquire ^1H - ^{13}C HSQC and ^1H - ^{13}C HMBC spectra.	To correlate protons to their directly attached carbons and to connect spin fragments through long-range couplings to quaternary carbons.
Regioisomer Ambiguity	Perform a 1D NOE or 2D NOESY experiment.	To establish through-space proximities between protons and determine the spatial arrangement of substituents.
Persistent Ambiguity	Use DFT calculations to predict NMR chemical shifts for all possible isomers.	To identify the isomer whose calculated spectrum best matches the experimental data.

IV. References

- Characterization of novel isobenzofuranones by DFT calculations and 2D NMR analysis. (2016). Magnetic Resonance in Chemistry. [\[Link\]](#)
- HMBC and HSQC data for compounds 2 and 3. ResearchGate. [\[Link\]](#)
- A Quest for Effective ^{19}F NMR Spectra Modeling: What Brings a Good Balance Between Accuracy and Computational Cost in Fluorine Chemical Shift Calculations? (2025). MDPI. [\[Link\]](#)
- Advanced NMR techniques for structural characterization of heterocyclic structures. (2012). Current Organic Chemistry. [\[Link\]](#)
- A Step-By-Step Guide to 1D and 2D NMR Interpretation. (2018). Emery Pharma. [\[Link\]](#)

- Advanced NMR techniques for structural characterization of heterocyclic structures. ESA-IPB. [\[Link\]](#)
- Signal Overlap in NMR Spectroscopy. (2018). YouTube. [\[Link\]](#)
- Band-selective NMR experiments for suppression of unwanted signals in complex mixtures. (2006). Magnetic Resonance in Chemistry. [\[Link\]](#)
- Nuclear Overhauser effect. Wikipedia. [\[Link\]](#)
- Basic 2D NMR experiments. University of Granada. [\[Link\]](#)
- Two-dimensional Experiments: Inverse Heteronuclear Correlation. Oxford Instruments. [\[Link\]](#)
- Synthesis, Characterization, Crystal structure and DFT calculations of 1-benzofuran-2-carboxylic acid. ResearchGate. [\[Link\]](#)
- 2D NMR FOR THE CHEMIST. University of Missouri-St. Louis. [\[Link\]](#)
- Advanced NMR techniques for structural characterization of heterocyclic structures. ESA-IPB. [\[Link\]](#)
- Predicting ^{19}F NMR Chemical Shifts: A Combined Computational and Experimental Study of a Trypanosomal Oxidoreductase–Inhibitor Complex. (2020). Angewandte Chemie International Edition. [\[Link\]](#)
- HSQC and HMBC. Columbia University. [\[Link\]](#)
- Comparison of ^1H NMR spectra in the dihydrobenzofuran (2-H and 3-H)... ResearchGate. [\[Link\]](#)
- Computational Prediction of Paramagnetic NMR Chemical Shifts in f-Element Complexes. University of Manchester. [\[Link\]](#)
- Benzofuranyl Esters: Synthesis, Crystal Structure Determination, Antimicrobial and Antioxidant Activities. (2022). Molecules. [\[Link\]](#)
- Short Summary of ^1H -NMR Interpretation. Minnesota State University Moorhead. [\[Link\]](#)

- Resolving ambiguities in two-dimensional NMR spectra: the 'TILT' experiment. (2005). Journal of Magnetic Resonance. [\[Link\]](#)
- A computational tool to accurately and quickly predict ^{19}F NMR chemical shifts of molecules with fluorine-carbon and fluorine-boron bonds. ChemRxiv. [\[Link\]](#)
- A computational tool to accurately and quickly predict ^{19}F NMR chemical shifts of molecules with fluorine-carbon and fluorine-boron bonds. (2022). Physical Chemistry Chemical Physics. [\[Link\]](#)
- Advanced NMR techniques for structural elucidation in medicinal chemistry. (2021). Diva-portal.org. [\[Link\]](#)
- Overlapping effect in a ^1H NMR spectrum of multiple metabolites. It... ResearchGate. [\[Link\]](#)
- 2D NMR Spectroscopy: COSY, HSQC (HMQC) and HMBC. (2020). YouTube. [\[Link\]](#)
- 22: Nuclear Overhauser Effect (NOE). Chemistry LibreTexts. [\[Link\]](#)
- Application of DFT Calculations in NMR Spectroscopy. (2024). YouTube. [\[Link\]](#)
- DFT- and Multiwfn-driven investigation of 1-benzofuran: Structural, topological, natural bond orbital, Hirshfeld surface, and interaction energy analyses, coupled with molecular docking of pyrazole and chalcone for anti-breast cancer exploration. (2025). AIP Publishing. [\[Link\]](#)
- Ultrabroadband 1D and 2D NMR Spectroscopy. (2025). Angewandte Chemie International Edition. [\[Link\]](#)
- 15.7: Spectroscopy of Aromatic Compounds. Chemistry LibreTexts. [\[Link\]](#)
- A review on nuclear Overhauser enhancement (NOE) and rotating-frame Overhauser effect (ROE) NMR techniques in food science. CORE. [\[Link\]](#)
- Main nuclear Overhauser effect (NOE) correlations observed in... ResearchGate. [\[Link\]](#)
- Introduction to 1D and 2D NMR Spectroscopy. NMR Wiki. [\[Link\]](#)
- Guide to Solving NMR Questions. The OChem Whisperer. [\[Link\]](#)

- Common HNMR Patterns. Organic Chemistry Tutor. [[Link](#)]
- Diversity-oriented synthesis of poly-substituted benzofuran derivatives bearing amino groups at 2- or 3-positions: Rh- or Ni-catalyzed cycloisomerization between ynamides and enol ethers. (2022). Organic Chemistry Frontiers. [[Link](#)]
- ¹H and ¹³C NMR spectral assignments of the benzodifuran core. ResearchGate. [[Link](#)]
- Three-Step Synthesis of an Array of Substituted Benzofurans Using Polymer-Supported Reagents. ResearchGate. [[Link](#)]
- Last Decade of Unconventional Methodologies for the Synthesis of Substituted Benzofurans. (2020). Molecules. [[Link](#)]
- NMR Spectroscopy of Aromatic Compounds (#1e). ResearchGate. [[Link](#)]
- Synthesis of polysubstituted benzofuran derivatives as novel inhibitors of parasitic growth. (2013). Bioorganic & Medicinal Chemistry. [[Link](#)]

Need Custom Synthesis?

BenchChem offers custom synthesis for rare earth carbides and specific isotopic labeling.

Email: info@benchchem.com or [Request Quote Online](#).

Sources

- 1. chem.libretexts.org [chem.libretexts.org]
- 2. emerypharma.com [emerypharma.com]
- 3. nmr.chem.columbia.edu [nmr.chem.columbia.edu]
- 4. m.youtube.com [m.youtube.com]
- 5. nmr.oxinst.com [nmr.oxinst.com]
- 6. Nuclear Overhauser effect - Wikipedia [en.wikipedia.org]
- 7. chem.libretexts.org [chem.libretexts.org]
- 8. fileserv-az.core.ac.uk [fileserv-az.core.ac.uk]

- [9. Characterization of novel isobenzofuranones by DFT calculations and 2D NMR analysis - PubMed \[pubmed.ncbi.nlm.nih.gov\]](#)
- [10. researchgate.net \[researchgate.net\]](#)
- [11. pubs.aip.org \[pubs.aip.org\]](#)
- [12. m.youtube.com \[m.youtube.com\]](#)
- [13. A computational tool to accurately and quickly predict ¹⁹F NMR chemical shifts of molecules with fluorine–carbon and fluorine–boron bonds - Physical Chemistry Chemical Physics \(RSC Publishing\) \[pubs.rsc.org\]](#)
- To cite this document: BenchChem. [Technical Support Center: Resolving Ambiguous NMR Spectra of Polysubstituted Benzofurans]. BenchChem, [2026]. [Online PDF]. Available at: [\[https://www.benchchem.com/product/b15186068/docs#technical-support-center-resolving-ambiguous-nmr-spectra-of-polysubstituted-benzofurans\]](https://www.benchchem.com/product/b15186068/docs#technical-support-center-resolving-ambiguous-nmr-spectra-of-polysubstituted-benzofurans)

Disclaimer & Data Validity:

The information provided in this document is for Research Use Only (RUO) and is strictly not intended for diagnostic or therapeutic procedures. While BenchChem strives to provide accurate protocols, we make no warranties, express or implied, regarding the fitness of this product for every specific experimental setup.

Technical Support: The protocols provided are for reference purposes. Unsure if this reagent suits your experiment?

Need Industrial/Bulk Grade? [Request Custom Synthesis Quote](#)

BenchChem

Our mission is to be the trusted global source of essential and advanced chemicals, empowering scientists and researchers to drive progress in science and industry.

Contact

Address: 3281 E Guasti Rd
Ontario, CA 91761, United States
Phone: (601) 213-4426
Email: info@benchchem.com

Contact our Ph.D. Support Team for a compatibility check