

# Technical Support Center: Avoiding Acid-Catalyzed Polymerization During Indole Nitration

**Author:** BenchChem Technical Support Team. **Date:** May 2026

## Compound of Interest

Compound Name: *tert-Butyl 3-(hydroxymethyl)-7-nitro-1H-indole-1-carboxylate*

CAS No.: 914349-15-8

Cat. No.: B1518813

[Get Quote](#)

Welcome to the technical support center for advanced organic synthesis. This guide is designed for researchers, scientists, and drug development professionals facing challenges with the nitration of indoles. Specifically, it addresses the prevalent issue of acid-catalyzed polymerization, a common pitfall that leads to low yields and complex purification challenges. Here, you will find in-depth troubleshooting advice, frequently asked questions (FAQs), and detailed experimental protocols to help you navigate the complexities of this essential transformation.

The indole nucleus is a cornerstone of many pharmaceuticals and bioactive molecules. Its functionalization through nitration is a key synthetic step, but the electron-rich and acid-sensitive nature of the indole ring makes this process non-trivial. This guide provides the technical insights and practical solutions to achieve successful and reproducible indole nitrations.

## Frequently Asked Questions (FAQs) & Troubleshooting

This section addresses common issues encountered during indole nitration in a direct question-and-answer format.

Q1: My indole nitration reaction turned into a dark, insoluble tar. What's happening and how can I prevent it?

A: The formation of a dark, tar-like substance is a classic sign of acid-catalyzed polymerization. [1][2] The electron-rich indole ring is highly susceptible to attack by strong acids, which are often used in traditional nitrating mixtures (e.g.,  $\text{HNO}_3/\text{H}_2\text{SO}_4$ ).

- Mechanism of Polymerization: The underlying issue is the protonation of the indole ring at the C-3 position by a strong acid. This generates a reactive indoleninium cation. This cation is a potent electrophile that can then attack the electron-rich pyrrole ring of another neutral indole molecule. This initiates a chain reaction, leading to the formation of high molecular weight polymers, which present as an intractable tar. [1][2][3]
- Prevention Strategies:
  - Avoid Strong Acids: The most effective way to prevent polymerization is to avoid strong, non-nucleophilic acids like sulfuric acid.
  - Use Milder Nitrating Agents: Opt for nitrating agents that do not require strongly acidic conditions. [1][4] Examples include benzoyl nitrate or the in situ generation of trifluoroacetyl nitrate. [5][6][7]
  - Low Temperatures: Conducting the reaction at low temperatures (e.g.,  $-20\text{ }^\circ\text{C}$  to  $0\text{ }^\circ\text{C}$ ) can help to minimize the rate of polymerization. [1]

Q2: What are the most common side products in indole nitration, besides polymers?

A: Besides polymerization, several other side products can form, complicating your purification process.

- Dinitrated Indoles: The formation of dinitroindoles is a common issue, especially when using potent nitrating agents or longer reaction times. The 3,5- and 3,6-dinitroindoles are frequently observed isomers. [1]

- Other Regioisomers: While the C-3 position is the most electron-rich and the primary site of electrophilic attack, nitration can also occur on the benzene ring, most notably at the C-6 position.[1]
- N-Nitrosoindoles: If nitrous acid is present (which can form from nitrite impurities), it can react with the indole to form N-nitrosoindoles.[1]

Q3: How can I control the regioselectivity of my indole nitration?

A: The regioselectivity of indole nitration is highly dependent on the reaction conditions.

- For C-3 Nitration: To favor nitration at the C-3 position, use milder, non-acidic conditions. Reagents like benzoyl nitrate or ethyl nitrate are effective for this purpose.[4][8][9]
- For Benzene Ring Nitration (e.g., C-5): Under strongly acidic conditions, the pyrrole nitrogen can be protonated, which deactivates the heterocyclic ring towards electrophilic attack. In such cases, nitration tends to occur on the benzene ring, often at the C-5 position.[2] However, these conditions also favor polymerization.
- N-Protecting Groups: The use of a protecting group on the indole nitrogen can influence the position of nitration.[1]

Q4: My indole has acid-sensitive functional groups. What are my options for nitration?

A: For acid-sensitive substrates, it is crucial to use non-acidic nitration methods.

- Trifluoroacetyl Nitrate (in situ): A highly effective method involves the in situ generation of trifluoroacetyl nitrate from tetramethylammonium nitrate and trifluoroacetic anhydride.[5][6][7] This protocol is mild, non-acidic, and non-metallic.[5][6][7]
- Ethyl Nitrate with a Base: Ethyl nitrate in the presence of a base like sodium ethoxide can be used to nitrate indole at low temperatures, yielding 3-nitroindole.[8]

Q5: I've already formed a polymeric mess. Is there any way to salvage my desired product?

A: While challenging, it may be possible to isolate your product from the polymeric byproduct.

- Solvent Precipitation: Try dissolving the crude mixture in a minimal amount of a moderately polar solvent (like dichloromethane or ethyl acetate) and then adding a non-polar solvent such as hexane. The polymer may precipitate, leaving your desired product in the solution.[2]
- Advanced Chromatographic Techniques: Instead of isocratic elution, use a solvent gradient in your column chromatography. Starting with a non-polar solvent and gradually increasing the polarity can improve the separation of your product from closely eluting impurities.[2]

## Visualizing the Problem: The Mechanism of Acid-Catalyzed Polymerization

To better understand the core issue, the following diagram illustrates the chain reaction that leads to indole polymerization in the presence of a strong acid.

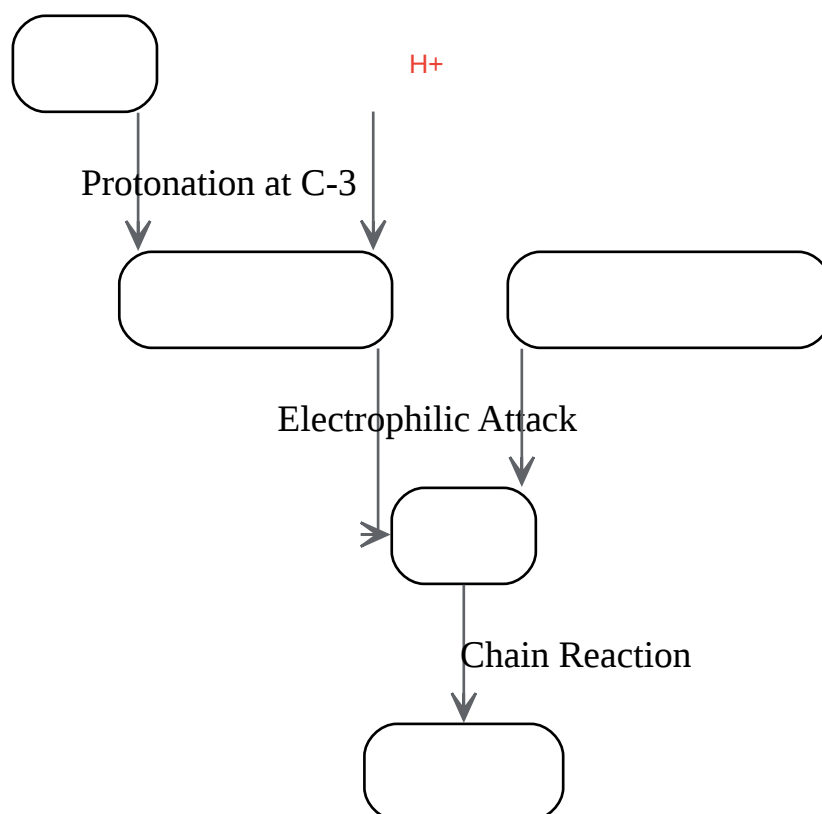

[Click to download full resolution via product page](#)

Caption: Acid-catalyzed polymerization of indole.

## Recommended Protocols for Avoiding Polymerization

Here are detailed, step-by-step methodologies for key nitration experiments that minimize or eliminate acid-catalyzed polymerization.

### Protocol 1: C-3 Nitration of Indole using in situ Generated Trifluoroacetyl Nitrate

This is a highly recommended method for the regioselective C-3 nitration of indoles under non-acidic and non-metallic conditions.<sup>[2][5]</sup>

Materials:

- Indole substrate
- Tetramethylammonium nitrate
- Acetonitrile
- Trifluoroacetic anhydride
- Saturated aqueous sodium bicarbonate solution

Procedure:

- To a reaction tube, add the indole substrate (1.0 mmol) and tetramethylammonium nitrate (1.1 mmol).
- Dissolve the mixture in acetonitrile (5 mL).
- Cool the reaction mixture to 0 °C in an ice bath.
- Slowly add a solution of trifluoroacetic anhydride (1.2 mmol) in acetonitrile (2 mL) to the cooled mixture.
- Stir the reaction at 0 °C and monitor its progress by thin-layer chromatography (TLC).

- Upon completion, quench the reaction by adding a saturated aqueous solution of sodium bicarbonate.
- Proceed with a standard aqueous work-up and purification by column chromatography.

## Protocol 2: Nitration using Benzoyl Nitrate

Benzoyl nitrate is a milder nitrating agent that can provide better control and avoid the harsh conditions of mixed acids.<sup>[1]</sup>

Materials:

- Indole substrate
- Benzoyl nitrate
- Appropriate solvent (e.g., acetonitrile or dichloromethane)

Procedure:

- Dissolve the indole substrate in the chosen solvent in a round-bottom flask.
- Cool the solution to a low temperature (e.g., -10 °C to 0 °C).
- Add a solution of benzoyl nitrate in the same solvent dropwise, maintaining the low temperature.
- Monitor the reaction by TLC.
- Upon completion, quench the reaction and proceed with work-up and purification.

## Comparative Data: Nitrating Agents for Indole

The choice of nitrating agent is critical for a successful reaction. The following table summarizes the performance of various agents.

Nitrating Agent	Conditions	Typical Regioselectivity	Advantages	Disadvantages
HNO <sub>3</sub> /H <sub>2</sub> SO <sub>4</sub>	Strongly acidic, low temp.	C-5, C-6	Inexpensive	High risk of polymerization, poor regioselectivity
Benzoyl Nitrate	Non-acidic, low temp.	C-3	Milder, better control	Can be less reactive for some substrates
Ethyl Nitrate	Basic (NaOEt), low temp.	C-3	Avoids acidic conditions	Requires careful handling of sodium ethoxide
Trifluoroacetyl Nitrate (in situ)	Non-acidic, non-metallic, 0 °C	C-3	High regioselectivity, mild	Requires in situ preparation

## The Role of Protecting Groups

For particularly sensitive indole substrates, or when a high degree of control is required, using a protecting group on the indole nitrogen is a valuable strategy.

- Mechanism of Action: An electron-withdrawing protecting group (e.g., Boc, Ts) reduces the electron density of the pyrrole ring, making it less susceptible to both electrophilic attack and acid-catalyzed polymerization.<sup>[1]</sup> This can also influence the regioselectivity of the nitration.
- Common Protecting Groups:
  - Boc (tert-butyloxycarbonyl): Easily introduced and removed under mild conditions.<sup>[1]</sup>
  - Ts (Tosyl): A robust protecting group, often used in multi-step syntheses.<sup>[1]</sup>

The following diagram illustrates the decision-making process for choosing a nitration strategy.

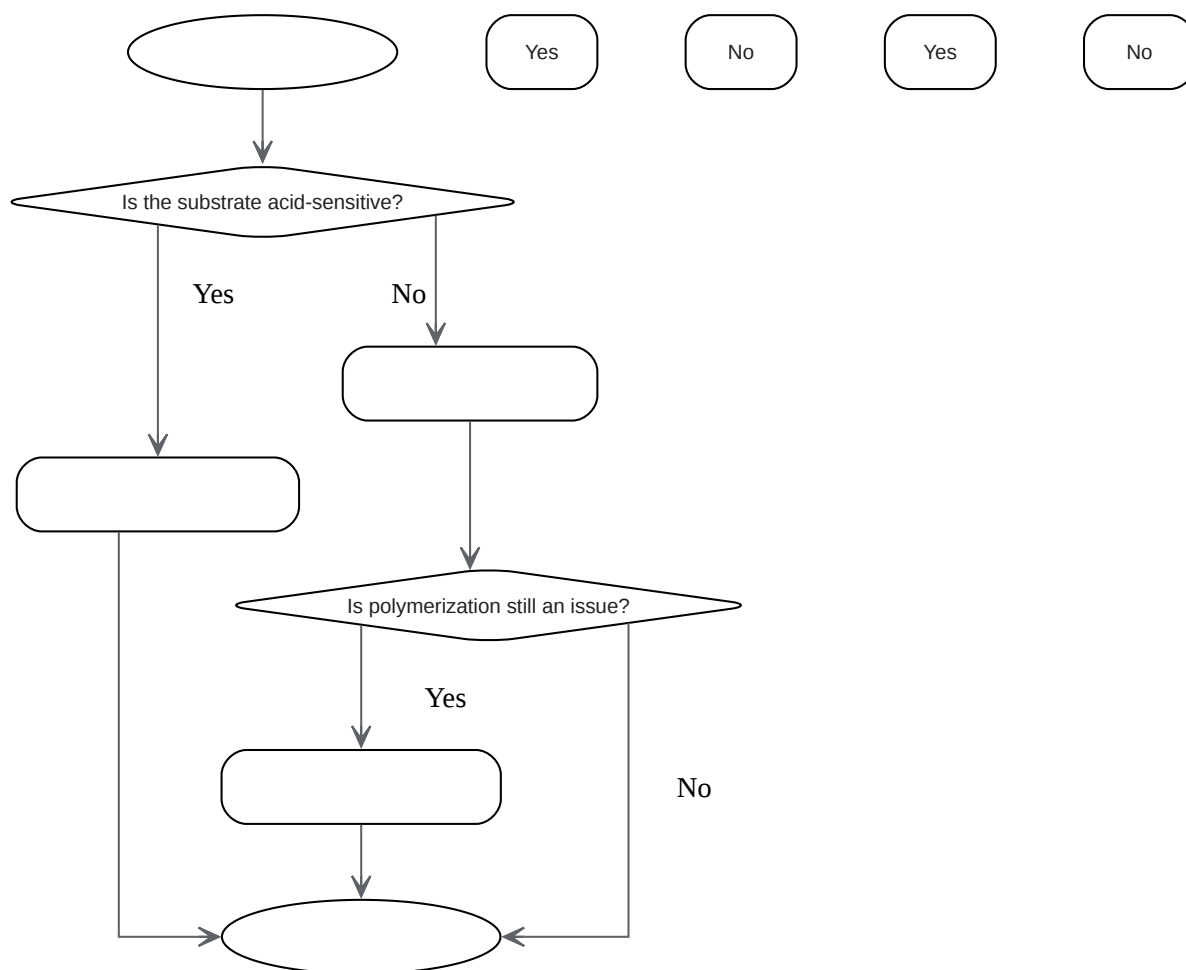

[Click to download full resolution via product page](#)

Caption: Decision workflow for indole nitration.

By carefully considering the nature of your indole substrate and selecting the appropriate reagents and conditions, you can successfully navigate the challenges of indole nitration and avoid the pitfalls of acid-catalyzed polymerization.

### Need Custom Synthesis?

BenchChem offers custom synthesis for rare earth carbides and specific isotopic labeling.

Email: [info@benchchem.com](mailto:info@benchchem.com) or [Request Quote Online](#).

## References

- [1. benchchem.com \[benchchem.com\]](#)
- [2. benchchem.com \[benchchem.com\]](#)
- [3. researchgate.net \[researchgate.net\]](#)
- [4. bhu.ac.in \[bhu.ac.in\]](#)
- [5. Regioselective synthesis of 3-nitroindoles under non-acidic and non-metallic conditions - RSC Advances \(RSC Publishing\) DOI:10.1039/D3RA03193D \[pubs.rsc.org\]](#)
- [6. pubs.rsc.org \[pubs.rsc.org\]](#)
- [7. Regioselective synthesis of 3-nitroindoles under non-acidic and non-metallic conditions - PMC \[pmc.ncbi.nlm.nih.gov\]](#)
- [8. uop.edu.pk \[uop.edu.pk\]](#)
- [9. scribd.com \[scribd.com\]](#)
- To cite this document: BenchChem. [Technical Support Center: Avoiding Acid-Catalyzed Polymerization During Indole Nitration]. BenchChem, [2026]. [Online PDF]. Available at: [\[https://www.benchchem.com/product/b1518813/docs#technical-support-center-avoiding-acid-catalyzed-polymerization-during-indole-nitration\]](https://www.benchchem.com/product/b1518813/docs#technical-support-center-avoiding-acid-catalyzed-polymerization-during-indole-nitration)

---

### Disclaimer & Data Validity:

The information provided in this document is for Research Use Only (RUO) and is strictly not intended for diagnostic or therapeutic procedures. While BenchChem strives to provide accurate protocols, we make no warranties, express or implied, regarding the fitness of this product for every specific experimental setup.

**Technical Support:** The protocols provided are for reference purposes. Unsure if this reagent suits your experiment?

**Need Industrial/Bulk Grade?** [Request Custom Synthesis Quote](#)

## BenchChem

Our mission is to be the trusted global source of essential and advanced chemicals, empowering scientists and researchers to drive progress in science and industry.

### Contact

Address: 3281 E Guasti Rd  
Ontario, CA 91761, United States  
Phone: (601) 213-4426  
Email: [info@benchchem.com](mailto:info@benchchem.com)

[Contact our Ph.D. Support Team for a compatibility check](#)