

# Application Notes and Protocols for NEO-823 in Optical Modulators

**Author:** BenchChem Technical Support Team. **Date:** April 2026

## Compound of Interest

Compound Name:	NEO-823
CAS No.:	1267603-73-5
Cat. No.:	B1518082

[Get Quote](#)

For Researchers, Scientists, and Drug Development Professionals

## Introduction to NEO-823

**NEO-823** is an organic non-linear optical (NLO) material characterized by a high electro-optic (EO) effect.[1] Such materials are pivotal for the advancement of optical communication networks, where they are used in electro-optic modulators to convert electrical signals into optical signals.[1] Organic NLO materials, like **NEO-823**, are gaining significant attention as they have the potential to surpass the speed limitations of conventional inorganic dielectric materials used in optical devices.[1]

**NEO-823** is typically utilized as a "guest" chromophore within a "host" polymer matrix. A common and effective approach involves blending **NEO-823** into polymethylmethacrylate (PMMA) to create a guest-host EO polymer.[1] This resulting polymer film can then be integrated into optical modulator architectures, such as Mach-Zehnder interferometers, to enable high-speed data transmission for applications like 5G networks, cloud computing, and advanced photonics research.[2]

## Principle of Operation: The Electro-Optic Effect in NEO-823 Polymer Blends

The functionality of **NEO-823** in an optical modulator is based on the Pockels effect, a linear electro-optic phenomenon where the refractive index of a material changes in proportion to an applied external electric field. To exhibit the Pockels effect, the NLO chromophores (**NEO-823**) within the polymer matrix must be arranged in a non-centrosymmetric manner. This is achieved through a critical process called electric-field poling.

During poling, the polymer blend is heated above its glass transition temperature ( $T_g$ ), and a strong DC electric field is applied. This allows the **NEO-823** chromophores, which possess a large dipole moment, to align with the electric field. The material is then cooled back to room temperature with the field still applied, locking the chromophores in their aligned, non-centrosymmetric orientation. Once poled, applying a modulating electrical signal (RF signal) to the material will alter its refractive index, thereby modulating the phase of light passing through it.

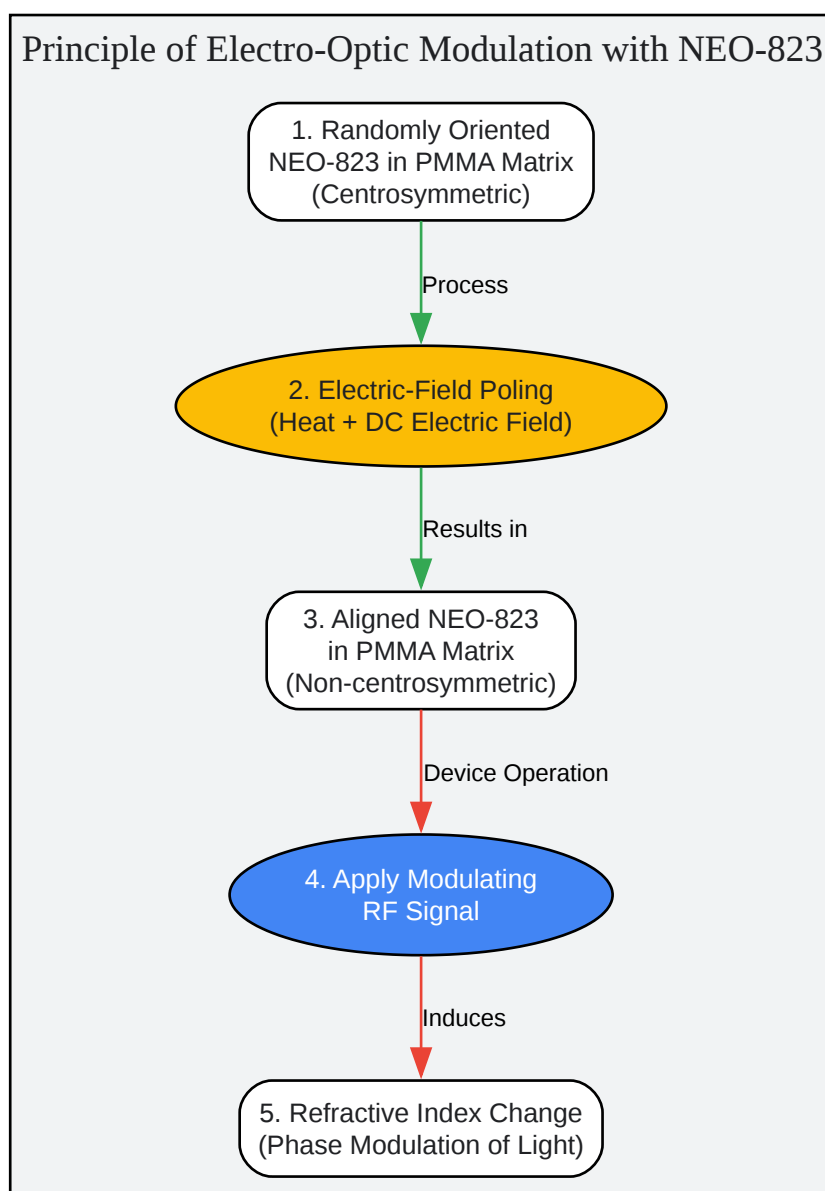

[Click to download full resolution via product page](#)

**Figure 1:** Principle of inducing and utilizing the electro-optic effect in a **NEO-823** guest-host polymer.

## Applications in High-Speed Optical Modulators

The primary application of **NEO-823** is as the active material in high-performance electro-optic modulators. By integrating the **NEO-823/PMMA** polymer into a silicon-organic hybrid (SOH) Mach-Zehnder modulator (MZM), it is possible to create devices with several key advantages:

- **High Bandwidth:** Organic EO polymers facilitate ultra-high-speed operation, potentially exceeding 100 GHz.
- **Low Power Consumption:** SOH devices can achieve a low half-wave voltage-length product ( $V\pi L$ ), leading to reduced power requirements.
- **Compact Footprint:** The silicon photonics platform allows for the fabrication of highly compact modulators.

These characteristics make **NEO-823**-based modulators suitable for next-generation optical interconnects in data centers, telecommunication systems, and sensing applications.

## Quantitative Data Summary

While specific performance data for **NEO-823** is not extensively available in public literature, the following table summarizes typical performance metrics for high-performance organic NLO guest-host polymers in SOH modulators. These values serve as a benchmark for what may be achievable with an optimized **NEO-823** based device.

Parameter	Symbol	Typical Value Range	Unit	Significance
Electro-Optic Coefficient	$r_{33}$	70 - 150	pm/V	Measures the strength of the material's electro-optic effect.
Half-Wave Voltage-Length Product	$V_{\pi}L$	0.3 - 1.0	V·cm	A key figure of merit for modulator efficiency; lower is better.
Optical Insertion Loss	IL	1.0 - 2.5	dB/cm	Represents the optical power lost as light propagates through the device.
Modulation Bandwidth	$f_{3dB}$	> 100	GHz	The maximum frequency at which the modulator can effectively operate.
Extinction Ratio	ER	> 20	dB	The ratio of maximum to minimum optical power at the output.
Glass Transition Temperature	$T_g$	150 - 200	°C	Indicates the thermal stability of the poled chromophore alignment.

## Experimental Protocols

The following sections provide detailed protocols for the preparation and characterization of a **NEO-823** based electro-optic modulator. These are based on established procedures for similar organic NLO materials.

### Protocol 1: Preparation of NEO-823/PMMA Electro-Optic Polymer Film

This protocol describes the creation of a guest-host polymer solution and its deposition as a thin film.

Materials and Equipment:

- **NEO-823** chromophore powder
- Polymethylmethacrylate (PMMA)
- Anisole (or other suitable solvent)
- 0.2  $\mu\text{m}$  syringe filters
- Glass substrates or silicon wafers
- Magnetic stirrer and hotplate
- Spin coater
- Vacuum oven

Procedure:

- Solution Preparation:
  1. In a clean glass vial, dissolve PMMA in anisole to a concentration of approximately 10-15% by weight. Stir overnight on a magnetic stirrer to ensure complete dissolution.

2. Add **NEO-823** powder to the PMMA solution to achieve a final chromophore loading of 15-25% by weight relative to the PMMA.
  3. Stir the mixture in a sealed vial at 40-50 °C for 2-4 hours until the **NEO-823** is fully dissolved.
  4. Cool the solution to room temperature and filter it through a 0.2 µm syringe filter to remove any particulate matter.
- Thin Film Deposition:
    1. Clean the desired substrates (e.g., silicon wafer with a bottom cladding layer) using a standard cleaning procedure (e.g., piranha etch or sonication in acetone and isopropanol).
    2. Dispense the filtered **NEO-823**/PMMA solution onto the center of the substrate.
    3. Spin coat the solution at a speed of 1000-3000 RPM for 30-60 seconds to achieve the desired film thickness.
    4. Transfer the coated substrate to a hotplate and soft bake at 80-100 °C for 5-10 minutes to remove the bulk of the solvent.
    5. Hard bake the film in a vacuum oven at a temperature slightly below the T<sub>g</sub> of the blend for several hours to remove residual solvent.

## Protocol 2: Fabrication and Poling of a Silicon-Organic Hybrid (SOH) Modulator

This protocol outlines the integration of the EO polymer with a silicon photonic chip and the critical poling process.

**Figure 2:** Workflow for the fabrication and poling of a **NEO-823** based SOH modulator.

Materials and Equipment:

- Pre-fabricated silicon photonic chip with slot-waveguide MZM structure and integrated electrodes.

- **NEO-823/PMMA** coated substrate (from Protocol 5.1).
- Poling setup: high-voltage source, temperature-controlled stage, and electrical probes.
- Nitrogen-purged environment or vacuum chamber.

#### Procedure:

- **Device Preparation:** The process starts with a silicon chip that has a pre-patterned MZM, typically with a narrow slot (~100-200 nm) in the waveguide arms. This slot will be filled by the EO polymer.
- **EO Polymer Application:** Apply the **NEO-823/PMMA** film as described in Protocol 5.1, ensuring the polymer solution completely fills the slot waveguides.
- **Poling:**
  1. Place the device on the temperature-controlled stage within a nitrogen-purged chamber.
  2. Connect the integrated electrodes to the high-voltage source using microprobes.
  3. Heat the device to a temperature approximately 5-10 °C above the glass transition temperature ( $T_g$ ) of the polymer blend.
  4. Apply a DC poling voltage across the slot waveguide. The required electric field is typically in the range of 100-150 V/ $\mu\text{m}$ .
  5. Maintain the temperature and voltage for 5-10 minutes to allow for chromophore alignment.
  6. While maintaining the poling voltage, cool the device slowly back to room temperature.
  7. Once at room temperature, the poling voltage can be switched off. The chromophore alignment is now locked in.

## Protocol 3: Electro-Optic Characterization

This protocol describes how to measure the key performance metric,  $V_{\pi L}$ , of the fabricated modulator.

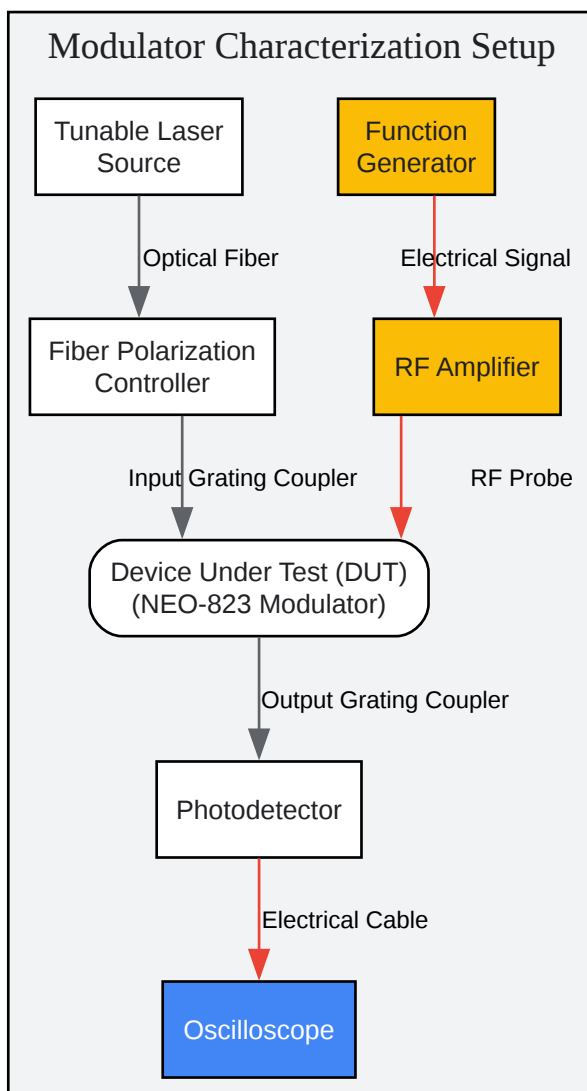

[Click to download full resolution via product page](#)

**Figure 3:** Schematic of the experimental setup for characterizing an EO modulator.

Materials and Equipment:

- Poled **NEO-823** SOH modulator chip.
- Tunable laser source (C-band).

- Fiber polarization controller.
- Input and output fiber optic grating couplers/probes.
- Function generator (for low-frequency testing).
- Vector network analyzer (VNA, for high-frequency testing).
- Photodetector.
- Oscilloscope.

#### Procedure for $V\pi$ Measurement:

- Setup: Assemble the characterization setup as shown in Figure 3.
- Optical Alignment:
  1. Set the laser to a specific wavelength (e.g., 1550 nm).
  2. Couple light into the SOH modulator chip using an input grating coupler.
  3. Optimize the polarization with the fiber polarization controller to maximize coupling to the TE mode of the silicon waveguide.
  4. Align the output fiber to the output grating coupler and connect it to the photodetector.
- Modulation Test:
  1. Apply a low-frequency (e.g., 1 kHz) triangular wave voltage from the function generator to the modulator's electrodes.
  2. Observe the modulated optical signal on the oscilloscope, which should be a sinusoidal-like intensity waveform.
  3. Slowly increase the peak-to-peak voltage ( $V_{pp}$ ) of the triangular wave until the optical output signal goes through one full cycle (from a minimum, through a maximum, to the next minimum).

4. The voltage required to shift the phase by  $\pi$  (from maximum to minimum output) is the half-wave voltage,  $V\pi$ .
5. The  $V\pi L$  product can be calculated by multiplying the measured  $V\pi$  by the known length (L) of the phase shifter in the MZM arm.

## Conclusion

**NEO-823** represents a promising organic NLO material for the development of next-generation electro-optic modulators. By employing the protocols outlined in this document, researchers can prepare **NEO-823**/PMMA films, fabricate high-performance SOH devices, and characterize their electro-optic properties. The combination of high electro-optic activity with the mature silicon photonics platform paves the way for compact, high-bandwidth, and energy-efficient modulators for a wide array of applications in science and technology.

### Need Custom Synthesis?

BenchChem offers custom synthesis for rare earth carbides and specific isotopic labeling.

Email: [info@benchchem.com](mailto:info@benchchem.com) or [Request Quote Online](#).

## References

- [1. WO2016154764A3 - Electrooptic modulator - Google Patents \[patents.google.com\]](#)
- [2. nlmphotonics.com \[nlmphotonics.com\]](#)
- To cite this document: BenchChem. [Application Notes and Protocols for NEO-823 in Optical Modulators]. BenchChem, [2026]. [Online PDF]. Available at: [\[https://www.benchchem.com/product/b1518082/docs#application-notes-and-protocols-for-neo-823-in-optical-modulators\]](https://www.benchchem.com/product/b1518082/docs#application-notes-and-protocols-for-neo-823-in-optical-modulators)

### Disclaimer & Data Validity:

The information provided in this document is for Research Use Only (RUO) and is strictly not intended for diagnostic or therapeutic procedures. While BenchChem strives to provide accurate protocols, we make no warranties, express or implied, regarding the fitness of this product for every specific experimental setup.

**Technical Support:** The protocols provided are for reference purposes. Unsure if this reagent suits your experiment?

**Need Industrial/Bulk Grade?** [Request Custom Synthesis Quote](#)

## BenchChem

Our mission is to be the trusted global source of essential and advanced chemicals, empowering scientists and researchers to drive progress in science and industry.

### Contact

Address: 3281 E Guasti Rd  
Ontario, CA 91761, United States  
Phone: (601) 213-4426  
Email: [info@benchchem.com](mailto:info@benchchem.com)

[Contact our Ph.D. Support Team for a compatibility check](#)