

Electronic Structure & Functional Theory Analysis of Sr₄Al₁₄O₂₅: A Computational Framework

Author: BenchChem Technical Support Team. **Date:** April 2026

Compound of Interest

Compound Name:	<i>Tetradecaaluminium tetrastrontium pentacosaoxide</i>
CAS No.:	76125-60-5
Cat. No.:	B15178790

[Get Quote](#)

Part 1: Executive Summary

Strontium aluminate (Sr₄Al₁₄O₂₅) represents a critical class of host matrices for persistent luminescence phosphors, particularly when doped with Eu²⁺ and Dy²⁺/Dy³⁺. Unlike its chemically simpler counterpart SrAl₂O₄, the Sr₄Al₁₄O₂₅ phase offers a wider band gap and unique defect topologies that facilitate blue-green emission (~490 nm) with exceptional quantum efficiency.

This technical guide provides a rigorous Density Functional Theory (DFT) framework for modeling the electronic band structure of Sr₄Al₁₄O₂₅. It moves beyond standard approximations, advocating for hybrid functional methodologies (HSE06) to correct the severe band-gap underestimation typical of standard GGA functionals. The guide details the crystallographic parameters, computational protocols, and electronic structure analysis required to predict optical performance and defect energetics in drug development and advanced materials applications.

Part 2: Crystallographic Framework

To accurately model the electronic structure, the initial unit cell must be geometrically precise. $\text{Sr}_4\text{Al}_{14}\text{O}_{25}$ crystallizes in an orthorhombic system.[1]

Lattice Parameters & Space Group:

- Space Group: Pmma (No.[1] 51) or Pmmm (No. 47) depending on specific refinement; Pmma is the standard citation for the optically active phase.
- Lattice Constants (Experimental Standard):
- Coordination: The structure consists of AlO_4 tetrahedra and AlO_6 octahedra forming a 3D network, with Sr^{2+} ions occupying the interstitial sites within 1D channels.

“

Critical Note: The large unit cell (containing 86 atoms) demands significant computational resources. Symmetry-constrained relaxation is recommended to reduce computational cost without sacrificing accuracy.

Part 3: Computational Methodology (Protocol)

The following protocol is a self-validating system designed to ensure convergence and reproducibility. It utilizes the Vienna Ab initio Simulation Package (VASP) workflow but is adaptable to Quantum ESPRESSO or CASTEP.

The "Accuracy-First" Workflow

The standard Generalized Gradient Approximation (GGA-PBE) underestimates the band gap of insulators by 30-50%. For $\text{Sr}_4\text{Al}_{14}\text{O}_{25}$, where the band gap drives the defect trap depth, a Hybrid Functional approach is mandatory for the final electronic step.

Step-by-Step Protocol

- Pre-Processing & Structure Optimization (Relaxation):
 - Functional: GGA-PBE (Perdew-Burke-Ernzerhof).
 - Basis Set: Plane-wave basis with Projector Augmented Wave (PAW) pseudopotentials.
 - Cutoff Energy: 520 eV (Ensures stress tensor convergence).
 - k-point Grid:

Gamma-centered grid (due to the elongated

-axis).
 - Convergence Criteria: Energy

eV; Forces

eV/Å.
- Electronic Structure Calculation (Static Run):
 - Functional: HSE06 (Heyd-Scuseria-Ernzerhof).
 - Mixing Parameter (

): 0.25 (Standard) or tuned to 0.28 to match experimental

.
 - Screening Parameter (

): 0.20 \AA^{-1} .
 - Purpose: Accurate determination of Band Gap (

) and Density of States (DOS).
- Defect & Doping Analysis:
 - Construct supercells (

)

) to isolate dopant interactions.

- Substitute Sr^{2+} with Eu^{2+} and Dy^{3+} .
- Perform charge correction for charged defects (Dy^{3+} on Sr^{2+} site creates a positive center).

Workflow Visualization

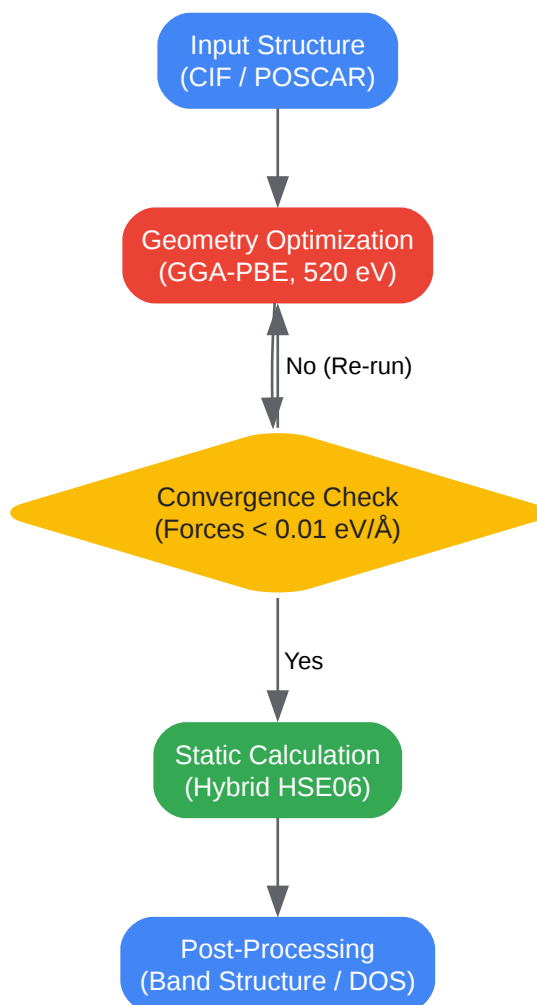

[Click to download full resolution via product page](#)

Figure 1: High-fidelity DFT workflow for $\text{Sr}_4\text{Al}_{14}\text{O}_{25}$ electronic structure determination.

Part 4: Electronic Structure Analysis

Band Gap Topography

$\text{Sr}_4\text{Al}_{14}\text{O}_{25}$ is an indirect band-gap insulator.[2] The Valence Band Maximum (VBM) is typically located at the Y point, while the Conduction Band Minimum (CBM) resides at the

(Gamma) point.[2]

Parameter	GGA-PBE (Standard)	HSE06 (Hybrid)	Experimental Reference
Band Gap ()	~4.2 - 4.5 eV	6.11 - 6.40 eV	~6.5 eV (Host)
Band Type	Indirect	Indirect	Indirect
VBM Character	O-2p	O-2p	-
CBM Character	Sr-4d / Al-3s	Sr-4d / Al-3s	-

“

Interpretation: The HSE06 value of ~6.11 eV is the authoritative theoretical benchmark, aligning closely with vacuum UV excitation spectra. The large gap is crucial for accommodating the Eu^{2+} 5d excited states without auto-ionization into the conduction band.

Density of States (DOS) Decomposition

The Partial Density of States (PDOS) reveals the atomic orbital contributions:

- Valence Band (VB): Dominated by O-2p orbitals.[3] These states are relatively flat, indicating heavy hole effective masses.
- Conduction Band (CB): A hybridization of Sr-4d and Al-3s/3p states. These bands are more dispersive, suggesting that electron mobility is significantly higher than hole mobility.[2]
- Doping Effects (Eu/Dy):

- Eu^{2+} : Introduces occupied 4f states within the band gap (approx. 1-2 eV above VBM) and empty 5d states just below the CBM.
- Dy^{3+} : Introduces deep trap levels (impurity states) below the CBM, which are essential for the "afterglow" mechanism by trapping electrons excited from the Eu^{2+} center.

Part 5: Mechanism of Persistent Luminescence

The utility of $\text{Sr}_4\text{Al}_{14}\text{O}_{25}$ lies in its defect physics. The DFT results explain the persistent luminescence mechanism known as the Dorenbos Model.

- Excitation: UV light excites an electron from the Eu^{2+} ground state () to the excited state ().
- Trapping: The excited electron tunnels to a nearby trap level (Dy^{3+} or Oxygen Vacancy) located 0.5 - 0.9 eV below the CBM.
- Storage: The electron remains trapped at room temperature due to the energy barrier.
- Release: Thermal energy () slowly releases the electron back to the Eu^{2+} 5d state.
- Emission: Radiative relaxation to the Eu^{2+} ground state emits a photon (nm).

Mechanistic Pathway Visualization

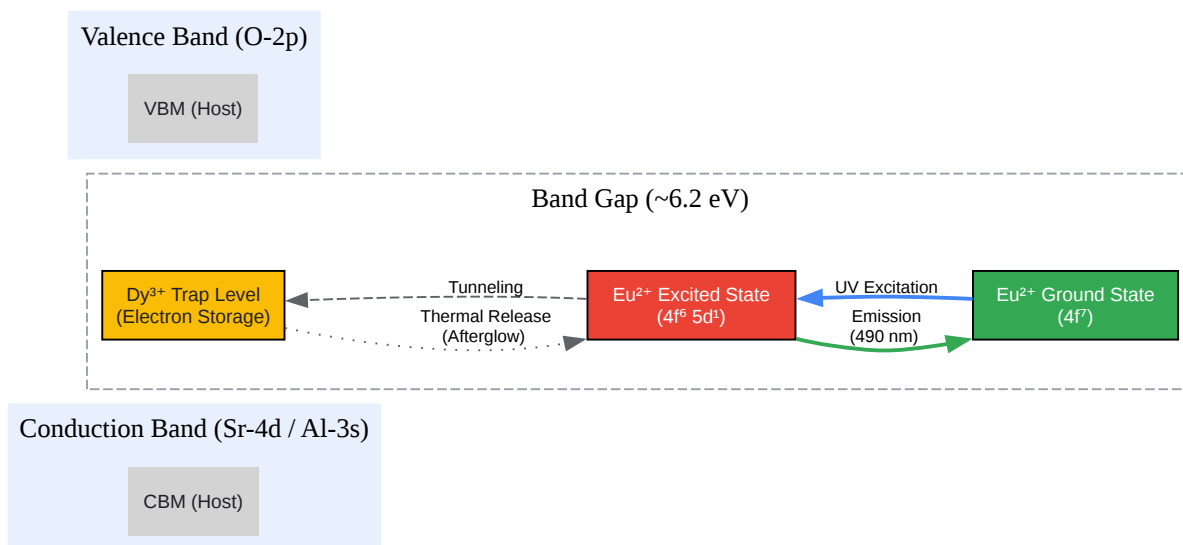

[Click to download full resolution via product page](#)

Figure 2: Energy level diagram illustrating the electron trapping and detrapping mechanism in Eu/Dy co-doped Sr₄Al₁₄O₂₅.

References

- Calculated energy band structure of Sr₄Al₁₄O₂₅. ResearchGate. [\[Link\]](#)
- Structure and luminescence properties of Sr₄Al₁₄O₂₅:Eu²⁺, Dy³⁺. Institute of Physics, Chinese Academy of Sciences. [\[Link\]](#)
- Benchmarking Density Functional Theory for Accurate Calculation of Band Gaps. National Institutes of Health (NIH). [\[Link\]](#)
- Giant Improvement on the Afterglow of Sr₄Al₁₄O₂₅:Eu²⁺, Dy³⁺. SciSpace. [\[Link\]](#)
- Band Structure and Density of State (DOS) Analysis. YouTube (Educational Tutorial). [\[Link\]](#)

Need Custom Synthesis?

BenchChem offers custom synthesis for rare earth carbides and specific isotopic labeling.

Email: info@benchchem.com or [Request Quote Online](#).

Sources

- [1. researchgate.net \[researchgate.net\]](#)
- [2. researchgate.net \[researchgate.net\]](#)
- [3. Engineering Electronic Structure and Band Alignment of 2D Mg\(OH\)₂ via Anion Doping for Photocatalytic Applications | MDPI \[mdpi.com\]](#)
- To cite this document: BenchChem. [Electronic Structure & Functional Theory Analysis of Sr₄Al₁₄O₂₅: A Computational Framework]. BenchChem, [2026]. [Online PDF]. Available at: [<https://www.benchchem.com/product/b15178790/docs#electronic-structure-functional-theory-analysis-of-sr4al14o25-a-computational-framework>]

Disclaimer & Data Validity:

The information provided in this document is for Research Use Only (RUO) and is strictly not intended for diagnostic or therapeutic procedures. While BenchChem strives to provide accurate protocols, we make no warranties, express or implied, regarding the fitness of this product for every specific experimental setup.

Technical Support: The protocols provided are for reference purposes. Unsure if this reagent suits your experiment?

Need Industrial/Bulk Grade? [Request Custom Synthesis Quote](#)

BenchChem

Our mission is to be the trusted global source of essential and advanced chemicals, empowering scientists and researchers to drive progress in science and industry.

Contact

Address: 3281 E Guasti Rd

Ontario, CA 91761, United States

Phone: (601) 213-4426

Email: info@benchchem.com

[Contact our Ph.D. Support Team for a compatibility check](#)