

GC-MS Profiling of Phosphite Antioxidant Degradation: A Comparative Guide

Author: BenchChem Technical Support Team. **Date:** May 2026

Compound of Interest

Compound Name: *2-Butoxyethyl didecyl phosphite*

CAS No.: 94006-31-2

Cat. No.: B15175034

[Get Quote](#)

Executive Summary: The Analytical Paradox

Phosphite antioxidants, particularly Tris(2,4-di-tert-butylphenyl)phosphite (Irgafos 168), are the industry standard for stabilizing polyolefins against thermal-oxidative degradation. However, their mechanism of action—sacrificial oxidation—creates a complex analytical challenge. The very products that confirm the antioxidant is working (oxidized phosphates and hydrolyzed phenols) are often chemically similar to the parent molecule or highly volatile.

While LC-MS is often the default for high-molecular-weight additives, GC-MS remains the superior tool for structural elucidation of unknown degradation products, particularly the volatile phenolic species that migrate easily and pose toxicological risks (NIAS - Non-Intentionally Added Substances).

This guide objectively compares GC-MS against LC-MS workflows, providing a validated protocol to overcome the primary limitation of GC-MS: thermal degradation artifacts during injection.

Mechanism of Action & Degradation Pathways[1]

To analyze degradation, one must first understand the specific chemical transformations. Irgafos 168 functions by decomposing hydroperoxides (

) formed during polymer processing, converting itself into a phosphate.[1]

Figure 1: Degradation Pathway of Irgafos 168

The following diagram illustrates the two primary degradation routes: Oxidation (functional) and Hydrolysis (parasitic/environmental).

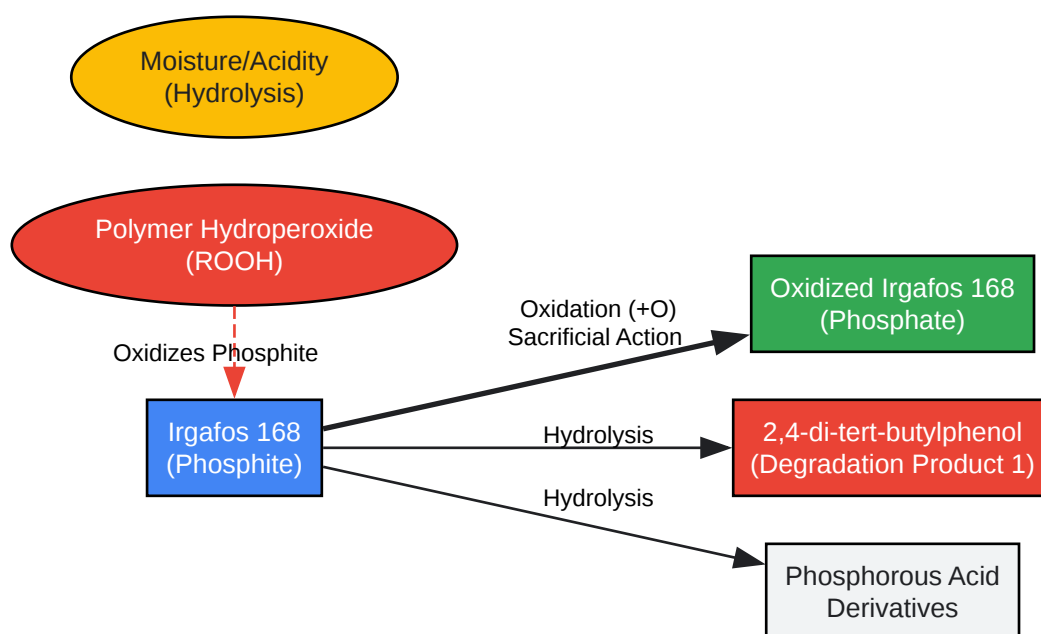

[Click to download full resolution via product page](#)

Caption: Figure 1.[2][3][4] Dual degradation pathways of Irgafos 168. Oxidation yields the stable phosphate, while hydrolysis cleaves the molecule into volatile phenols.

Comparative Analysis: GC-MS vs. LC-MS[6][7][8][9][10]

The choice between GC-MS and LC-MS is not binary; it depends on whether the target is the additive or the breakdown profile.

Table 1: Performance Matrix for Antioxidant Analysis

Feature	GC-MS (Electron Impact)	LC-MS (ESI/APCI)	Expert Verdict
Analyte Suitability	Excellent for volatile breakdown products (e.g., 2,4-di-tert-butylphenol).	Excellent for high MW parent compounds (Irgafos 168, Irganox 1010).	GC-MS is mandatory for NIAS/migration studies.
Identification Power	Superior. EI ionization provides fingerprint spectra matchable to NIST libraries.	Lower. Soft ionization (ESI) often yields only molecular ions (), making structural ID of unknowns difficult.	Use GC-MS for unknown identification.
Thermal Stability	Risk. Parent phosphites can oxidize in the injector (artifact formation).	High. Low-temperature separation prevents on-column degradation.	GC-MS requires Cool On-Column or optimized injection.
Sensitivity (LOD)	High (0.2–5.0 µg/L) for phenols.[4]	High for polar oxidized species.	Comparable, but GC wins for volatiles.[5][6]
Matrix Interference	High resolution capillary columns separate complex polymer matrices well.	Co-elution is common; requires high-end MS/MS for selectivity.	GC-MS offers better chromatographic resolution.[7]



Critical Insight: A common error in GC-MS analysis of phosphites is the "False Oxidation" artifact. If the GC injector temperature is too high (>280°C) or the liner is dirty, Irgafos 168 will oxidize to its phosphate form during injection. This leads to a false conclusion that the polymer has degraded more than it actually has.

Validated Experimental Protocol (GC-MS)

This protocol is designed to minimize thermal artifacts while maximizing the recovery of both the parent phosphite and its degradation products.

Sample Preparation (Microwave-Assisted Extraction)

Microwave extraction (MAE) is superior to Soxhlet due to shorter heating times, reducing the risk of artificial degradation during extraction [4].

- Cryo-milling: Grind polymer pellets to <math><500\ \mu\text{m}</math> powder using liquid nitrogen to prevent frictional heating.
- Solvent Selection: Use Isooctane or Dichloromethane.
 - Why: Irgafos 168 is highly soluble in isooctane, and it is less likely to cause hydrolysis compared to protic solvents.
- Extraction:
 - Solvent: 20 mL Isooctane per 1 g sample.
 - Temp: 70°C (Isooctane) or 40°C (DCM).
 - Time: 15–20 mins (Microwave) vs. 4–8 hours (Soxhlet).
- Filtration: 0.45 μm PTFE filter.

GC-MS Instrument Parameters

To analyze high-boiling phosphites (MW ~646) without degradation, a high-temperature column and careful thermal management are required.

- System: Agilent 7890/5977 or equivalent.
- Column: DB-5HT or ZB-5HT (15m x 0.25mm x 0.1 μm).
 - Note: A thinner film (0.1 μm) and shorter length (15m) elute high-boilers faster, reducing thermal stress.

- Injector: Pulsed Splitless or Cool On-Column (COC).
 - Temp: If not using COC, set injector to 250°C (do not exceed 280°C).
- Carrier Gas: Helium @ 1.5 mL/min (Constant Flow).
- Oven Program:
 - 50°C (hold 1 min) – Traps volatiles (phenols).
 - Ramp 20°C/min to 320°C.
 - Hold 5 min – Elutes Irgafos 168 and Phosphate.
- Mass Spec: Electron Impact (EI) @ 70eV. Scan range 40–800 amu.

Figure 2: Analytical Workflow

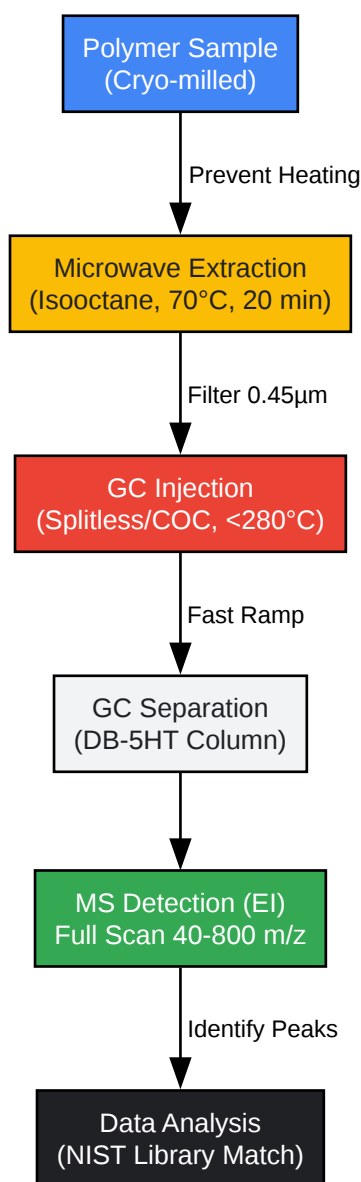

[Click to download full resolution via product page](#)

Caption: Figure 2. Optimized GC-MS workflow emphasizing thermal control to prevent artifact formation.

Results & Discussion: Interpreting the Data

Identification of Key Peaks

Using the protocol above, you will observe three distinct zones in the chromatogram:

- Early Elution (RT 3–6 min): 2,4-di-tert-butylphenol (DBP).

- Origin: Hydrolysis product.[8][9]
- Relevance: Major migrant in food contact materials.
- Key Ions: m/z 191 (Base peak), 206 (Molecular ion).
- Late Elution (RT 15–18 min):Irgafos 168 (Parent).
 - Key Ions: m/z 646 (), 441 (Fragment).
- Late Elution (RT 16–19 min):Tris(2,4-di-tert-butylphenyl)phosphate.
 - Origin: Oxidation product.[9][10]
 - Key Ions: m/z 662 (), 315.
 - Note: The phosphate elutes after the phosphite due to the added oxygen atom increasing polarity and mass.

Quantitative Performance (Validation Data)

Based on comparative studies [7], the GC-MS method yields the following performance metrics:

Analyte	Linearity ()	LOD (µg/L)	Recovery (%)
2,4-di-tert-butylphenol	0.9990	0.20	95–102
Irgafos 168	0.9989	5.00	82–96
Oxidized Phosphate	0.9955	25.00	85–115

Data Source: Validated against GB/T 23296.1-2009 standards and recent literature [7].

Conclusion

For the analysis of phosphite antioxidant degradation, GC-MS is the method of choice for comprehensive profiling, particularly when the migration of volatile breakdown products (phenols) is a concern. While LC-MS offers gentler conditions for the parent molecule, it lacks the spectral library depth to identify unexpected degradation pathways.

By utilizing microwave-assisted extraction and a high-temperature GC column with controlled injection temperatures, researchers can eliminate thermal artifacts and achieve precise, simultaneous quantification of the antioxidant and its degradation products.

References

- Wellt Chemicals. (2025). Irgafos 168 Degradation: Understanding the Antioxidant's Impact on Polypropylene and Migration.[Link](#)
- BenchChem. (2025). A Head-to-Head Comparison of GC-MS and LC-MS for the Analysis of 12-OAHSA.[Link](#)
- ResolveMass Laboratories. (2025). GC-MS vs LC-MS: Core Differences Explained.[Link](#)
- MDPI. (2024). Quantification of Irgafos P-168 and Degradative Profile in Samples of a Polypropylene/Polyethylene Composite Using Microwave, Ultrasound and Soxhlet Extraction Techniques.[8][Link](#)
- Frontier Lab. (2024). Determination of antioxidants (Irganox 1076 and Irganox 1010) in polyethylene using thermal desorption and reactive pyrolysis.[Link](#)
- Shimadzu. (2024). Detailed Analysis of an Unknown Polymer Using the Py-GC/MS System with Polymer Additives and F-Search.[Link](#)
- ResearchGate. (2016). Degradation of Irgafos 168 and determination of its degradation products: according to the procedure described in GB/T 23296.1-2009.[Link](#)

Need Custom Synthesis?

BenchChem offers custom synthesis for rare earth carbides and specific isotopic labeling.

Email: info@benchchem.com or [Request Quote Online](#).

Sources

- [1. researchgate.net \[researchgate.net\]](#)
- [2. Determination of the Contents of Antioxidants and Their Degradation Products in Sodium Chloride Injection for Blood Transfusion - PMC \[pmc.ncbi.nlm.nih.gov\]](#)
- [3. pdfs.semanticscholar.org \[pdfs.semanticscholar.org\]](#)
- [4. researchgate.net \[researchgate.net\]](#)
- [5. resolvemass.ca \[resolvemass.ca\]](#)
- [6. resolvemass.ca \[resolvemass.ca\]](#)
- [7. pdf.benchchem.com \[pdf.benchchem.com\]](#)
- [8. mdpi.com \[mdpi.com\]](#)
- [9. welltchemicals.com \[welltchemicals.com\]](#)
- [10. pubs.acs.org \[pubs.acs.org\]](#)
- To cite this document: BenchChem. [GC-MS Profiling of Phosphite Antioxidant Degradation: A Comparative Guide]. BenchChem, [2026]. [Online PDF]. Available at: [\[https://www.benchchem.com/product/b15175034/docs#gc-ms-profiling-of-phosphite-antioxidant-degradation-a-comparative-guide\]](https://www.benchchem.com/product/b15175034/docs#gc-ms-profiling-of-phosphite-antioxidant-degradation-a-comparative-guide)

Disclaimer & Data Validity:

The information provided in this document is for Research Use Only (RUO) and is strictly not intended for diagnostic or therapeutic procedures. While BenchChem strives to provide accurate protocols, we make no warranties, express or implied, regarding the fitness of this product for every specific experimental setup.

Technical Support: The protocols provided are for reference purposes. Unsure if this reagent suits your experiment?

Need Industrial/Bulk Grade? [Request Custom Synthesis Quote](#)

BenchChem

Our mission is to be the trusted global source of essential and advanced chemicals, empowering scientists and researchers to drive progress in science and industry.

Contact

Address: 3281 E Guasti Rd

Ontario, CA 91761, United States

Phone: (601) 213-4426

Email: info@benchchem.com

[Contact our Ph.D. Support Team for a compatibility check](#)