

Protocol for the Selective N-Acylation of 2,3-Diaminopyridin-4-ol

Author: BenchChem Technical Support Team. **Date:** December 2025

Compound of Interest

Compound Name: 2,3-Diaminopyridin-4-ol

Cat. No.: B15174216

[Get Quote](#)

Introduction

This application note provides a detailed protocol for the selective N-acylation of **2,3-diaminopyridin-4-ol**, a key intermediate in the synthesis of various pharmacologically active compounds. The selective acylation of polyfunctional molecules, such as diaminopyridines, is a critical step in drug development, enabling the fine-tuning of a molecule's biological activity, solubility, and pharmacokinetic profile. This protocol focuses on a robust and reproducible method for achieving mono-N-acylation, yielding the desired N-acyl-**2,3-diaminopyridin-4-ol** with high purity. The methodology is based on established principles of selective N-acylation of similar aromatic diamines and aminophenols.

The resulting N-acylated diaminopyridin-4-ol derivatives are of significant interest to researchers in drug discovery, particularly for their potential to modulate ion channels. The parent compound, 3,4-diaminopyridine (a structural analog lacking the 4-hydroxyl group), is a known blocker of voltage-gated potassium channels and is used in the treatment of certain neuromuscular disorders.[1][2][3][4] The N-acetylation of 3,4-diaminopyridine is a known metabolic pathway, resulting in the formation of 3-N-acetyl-3,4-diaminopyridine.[5] This suggests that N-acylated derivatives of diaminopyridines are biologically relevant and may exhibit unique pharmacological properties.

Experimental Protocol

This protocol describes the selective N-acetylation of **2,3-diaminopyridin-4-ol** using acetic anhydride. The procedure is designed to favor acylation at the more nucleophilic amino group.

Materials:

- **2,3-Diaminopyridin-4-ol**
- Acetic Anhydride (Ac_2O)
- Dry Pyridine
- Dry Dichloromethane (CH_2Cl_2) or Dry Ethyl Acetate (EtOAc)
- Methanol (MeOH)
- Toluene
- 1 M Hydrochloric Acid (HCl)
- Saturated aqueous Sodium Bicarbonate (NaHCO_3)
- Brine (saturated aqueous NaCl)
- Anhydrous Sodium Sulfate (Na_2SO_4) or Magnesium Sulfate (MgSO_4)
- Silica Gel (for column chromatography)
- Thin Layer Chromatography (TLC) plates (silica gel 60 F₂₅₄)

Equipment:

- Round-bottom flask
- Magnetic stirrer and stir bar
- Ice bath
- Rotary evaporator
- Separatory funnel
- Chromatography column

- Standard laboratory glassware

Procedure:

- **Reaction Setup:** In a clean, dry round-bottom flask, dissolve **2,3-diaminopyridin-4-ol** (1.0 equivalent) in dry pyridine (5-10 mL per mmol of substrate) under an inert atmosphere (e.g., argon or nitrogen).
- **Addition of Acylating Agent:** Cool the solution to 0°C using an ice bath. To this cooled solution, add acetic anhydride (1.1 equivalents) dropwise while stirring.
- **Reaction Monitoring:** Allow the reaction mixture to warm to room temperature and stir until the starting material is consumed. The progress of the reaction should be monitored by Thin Layer Chromatography (TLC).
- **Quenching:** Once the reaction is complete, quench the reaction by the slow addition of dry methanol (MeOH) to consume any excess acetic anhydride.
- **Work-up:**
 - Co-evaporate the reaction mixture with toluene to remove the pyridine.
 - Dilute the residue with dichloromethane (CH₂Cl₂) or ethyl acetate (EtOAc).
 - Wash the organic layer sequentially with 1 M HCl, water, saturated aqueous NaHCO₃, and brine.^[6]
 - Dry the organic layer over anhydrous Na₂SO₄ or MgSO₄, filter, and concentrate under reduced pressure using a rotary evaporator.^[6]
- **Purification:** Purify the crude product by silica gel column chromatography to obtain the pure N-acetyl-**2,3-diaminopyridin-4-ol**.

Data Presentation

While specific experimental data for the N-acylation of **2,3-diaminopyridin-4-ol** is not readily available in the public domain, the following tables present expected data based on the

acylation of the closely related compound, 3,4-diaminopyridine. The molecular weight of the N-acetylated product of 3,4-diaminopyridine is 151.18 g/mol .[5][7]

Table 1: Reaction Parameters and Expected Yield

Parameter	Value
Starting Material	2,3-Diaminopyridin-4-ol
Acylating Agent	Acetic Anhydride
Solvent	Pyridine
Reaction Temperature	0°C to Room Temperature
Expected Yield	70-90%

Table 2: Spectroscopic Data for a Representative N-Acyl Diaminopyridine Analog (N-acetyl-3,4-diaminopyridine)

Spectroscopic Technique	Expected Data
^1H NMR	Characteristic shifts for aromatic protons, acetyl methyl protons, and amine/amide protons.
^{13}C NMR	Characteristic shifts for aromatic carbons, carbonyl carbon, and acetyl methyl carbon.
FT-IR (cm^{-1})	Peaks corresponding to N-H stretching (amine and amide), C=O stretching (amide), and aromatic C-H and C=C stretching.
Mass Spectrometry (m/z)	Molecular ion peak corresponding to the mass of the N-acetylated product. For N-acetyl-3,4-diaminopyridine: $[\text{M}+\text{H}]^+ = 152$.

Visualizations

Experimental Workflow:

The following diagram illustrates the key steps in the N-acylation protocol.

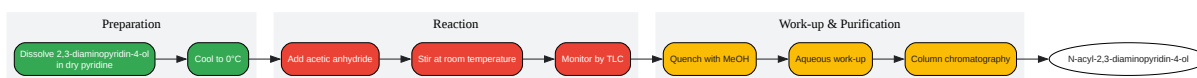

[Click to download full resolution via product page](#)

Caption: Experimental workflow for the N-acylation of **2,3-diaminopyridin-4-ol**.

Proposed Signaling Pathway:

The parent compound, 3,4-diaminopyridine, is known to block voltage-gated potassium (Kv) channels.[1][2][3][4] This action prolongs the depolarization of the presynaptic nerve terminal, leading to an increased influx of calcium ions through voltage-gated calcium (Cav) channels. The elevated intracellular calcium concentration enhances the release of neurotransmitters, such as acetylcholine, into the synaptic cleft. While the specific biological activity of N-acylated **2,3-diaminopyridin-4-ol** is yet to be fully elucidated, it is hypothesized to modulate neuronal signaling through a similar mechanism.

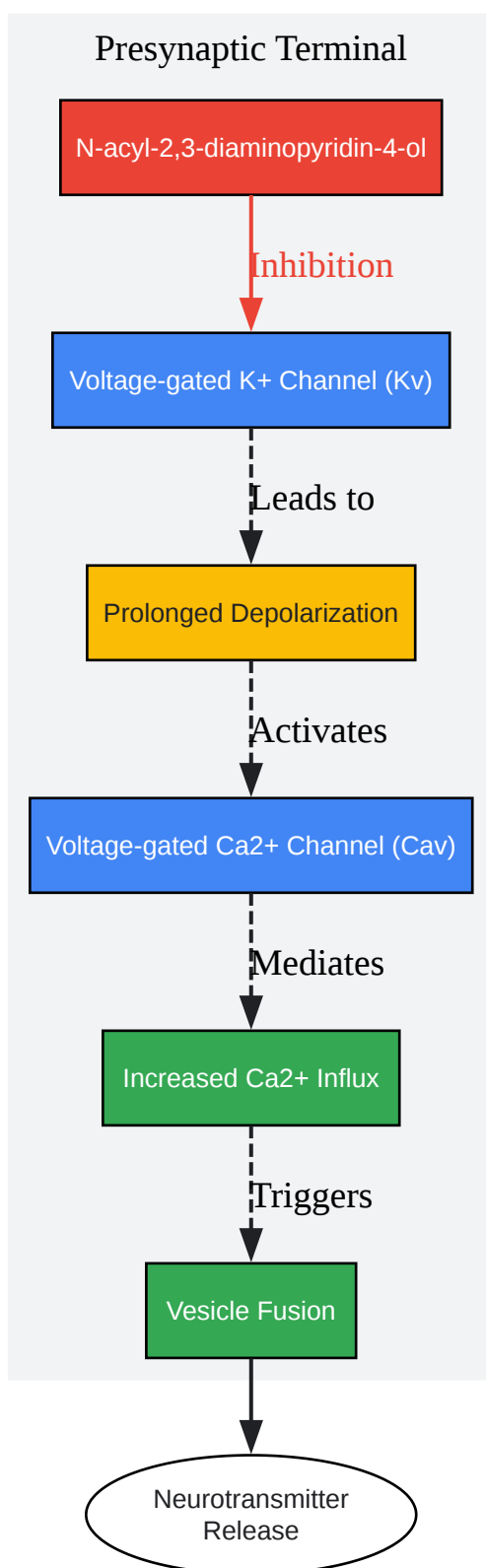

[Click to download full resolution via product page](#)

Need Custom Synthesis?

BenchChem offers custom synthesis for rare earth carbides and specific isotopic labeling.

Email: info@benchchem.com or [Request Quote Online](#).

References

- 1. myaware.org [myaware.org]
- 2. A high-affinity, partial antagonist effect of 3,4-diaminopyridine mediates action potential broadening and enhancement of transmitter release at NMJs - PMC [pmc.ncbi.nlm.nih.gov]
- 3. go.drugbank.com [go.drugbank.com]
- 4. 3,4-diaminopyridine for the treatment of Lambert-Eaton myasthenic syndrome - PubMed [pubmed.ncbi.nlm.nih.gov]
- 5. Population Pharmacokinetics/Pharmacodynamics of 3,4-Diaminopyridine Free Base in Patients With Lambert-Eaton Myasthenia - PMC [pmc.ncbi.nlm.nih.gov]
- 6. O-Acetylation using acetic anhydride in pyridine - Glycoscience Protocols (GlycoPODv2) - NCBI Bookshelf [ncbi.nlm.nih.gov]
- 7. researchgate.net [researchgate.net]
- To cite this document: BenchChem. [Protocol for the Selective N-Acylation of 2,3-Diaminopyridin-4-ol]. BenchChem, [2025]. [Online PDF]. Available at: [https://www.benchchem.com/product/b15174216#protocol-for-n-acylation-of-2-3-diaminopyridin-4-ol]

Disclaimer & Data Validity:

The information provided in this document is for Research Use Only (RUO) and is strictly not intended for diagnostic or therapeutic procedures. While BenchChem strives to provide accurate protocols, we make no warranties, express or implied, regarding the fitness of this product for every specific experimental setup.

Technical Support: The protocols provided are for reference purposes. Unsure if this reagent suits your experiment? [[Contact our Ph.D. Support Team for a compatibility check](#)]

Need Industrial/Bulk Grade? [Request Custom Synthesis Quote](#)

BenchChem

Our mission is to be the trusted global source of essential and advanced chemicals, empowering scientists and researchers to drive progress in science and industry.

Contact

Address: 3281 E Guasti Rd

Ontario, CA 91761, United States

Phone: (601) 213-4426

Email: info@benchchem.com