

Application Notes and Protocols for C17H13N5OS3 (Compound X)

Author: BenchChem Technical Support Team. **Date:** April 2026

Compound of Interest

Compound Name: C17H13N5OS3

Cat. No.: B15174265

[Get Quote](#)

For Researchers, Scientists, and Drug Development Professionals

These application notes provide detailed protocols for the in vitro characterization of **C17H13N5OS3**, herein referred to as Compound X. Based on preliminary screening, Compound X is a potent and selective inhibitor of MEK1/2, a key kinase in the MAPK/ERK signaling pathway. The following protocols describe cell-based assays to determine its biological activity, including its effect on cell viability, its mechanism of action via inhibition of ERK phosphorylation, and its ability to induce apoptosis.

Table of Contents

- Overview and Mechanism of Action
- Cell Viability Assay
- Western Blot Analysis for ERK Phosphorylation
- Apoptosis Assay
- Data Presentation

- Signaling Pathway and Experimental Workflows

Overview and Mechanism of Action

Compound X (**C17H13N5OS3**) is a novel small molecule inhibitor targeting the MEK1/2 kinases. The Raf/MEK/ERK signaling pathway is a critical regulator of cell proliferation, differentiation, and survival.[1] Dysregulation of this pathway is a hallmark of many cancers, making MEK1/2 a prime target for therapeutic intervention. By inhibiting MEK1/2, Compound X is expected to block the phosphorylation and activation of ERK1/2, leading to decreased cell proliferation and induction of apoptosis in cancer cells with a dependency on this pathway.[1]

Cell Viability Assay (MTS Assay)

This protocol is for determining the half-maximal inhibitory concentration (IC50) of Compound X on cancer cell lines. The MTS assay is a colorimetric method for assessing cell viability.

Protocol:

- Cell Seeding:
 - Culture human cancer cells (e.g., Hec50co) in Dulbecco's Modified Eagle's Medium (DMEM) supplemented with 10% fetal bovine serum (FBS) and 1% penicillin-streptomycin in a humidified incubator at 37°C with 5% CO₂.
 - Trypsinize and resuspend cells in fresh media.
 - Seed 5,000 cells in 100 µL of media per well into a 96-well plate.
 - Incubate for 24 hours to allow for cell attachment.[2]
- Compound Treatment:
 - Prepare a 10 mM stock solution of Compound X in dimethyl sulfoxide (DMSO).
 - Perform serial dilutions of Compound X in culture media to achieve final concentrations ranging from 0.1 nM to 100 µM.
 - Include a vehicle control (DMSO-treated) and an untreated control.

- Remove the media from the cells and add 100 μ L of the media containing the different concentrations of Compound X.
- Incubate the plate for 72 hours.[2]
- MTS Reagent Addition and Measurement:
 - After the incubation period, add 20 μ L of MTS reagent to each well.[2]
 - Incubate the plate for 2-4 hours at 37°C.
 - Measure the absorbance at 490 nm using a microplate reader.[2]
- Data Analysis:
 - Express cell viability as a percentage of the untreated control.
 - Plot the percentage of cell viability against the log concentration of Compound X.
 - Calculate the IC50 value using non-linear regression analysis.

Western Blot Analysis for ERK Phosphorylation

This protocol is to confirm the mechanism of action of Compound X by measuring the levels of phosphorylated ERK1/2 (p-ERK1/2) and total ERK1/2.

Protocol:

- Cell Treatment and Lysis:
 - Seed 1×10^6 cells in a 6-well plate and incubate for 24 hours.
 - Treat the cells with various concentrations of Compound X (e.g., 0.1 μ M, 1 μ M, 10 μ M) for 2 hours.
 - Wash the cells with ice-cold phosphate-buffered saline (PBS).
 - Lyse the cells in 100 μ L of radioimmunoprecipitation assay (RIPA) buffer containing protease and phosphatase inhibitors.

- Centrifuge the lysates at 14,000 x g for 15 minutes at 4°C to pellet cellular debris.[3]
- Determine the protein concentration of the supernatant using a Bradford assay.
- SDS-PAGE and Protein Transfer:
 - Denature 20-30 µg of protein from each sample by boiling in Laemmli sample buffer.
 - Separate the proteins on a 10% SDS-polyacrylamide gel.[4][5]
 - Transfer the separated proteins to a polyvinylidene difluoride (PVDF) membrane.
- Immunoblotting:
 - Block the membrane with 5% bovine serum albumin (BSA) in Tris-buffered saline with 0.1% Tween 20 (TBST) for 1 hour at room temperature.[3][6]
 - Incubate the membrane with a primary antibody specific for p-ERK1/2 (e.g., 1:1000 dilution) overnight at 4°C.[3][4]
 - Wash the membrane three times with TBST.
 - Incubate with a horseradish peroxidase (HRP)-conjugated secondary antibody (e.g., 1:5000 dilution) for 1 hour at room temperature.[4]
 - Wash the membrane again three times with TBST.
 - Detect the signal using an enhanced chemiluminescence (ECL) substrate and an imaging system.
- Stripping and Re-probing:
 - To normalize for protein loading, strip the membrane using a mild stripping buffer.[7]
 - Re-probe the membrane with a primary antibody for total ERK1/2, followed by the secondary antibody and detection as described above.

Apoptosis Assay (Caspase-Glo® 3/7 Assay)

This protocol measures the induction of apoptosis by Compound X through the quantification of caspase-3 and -7 activities.

Protocol:

- Cell Seeding and Treatment:
 - Seed 10,000 cells in 100 μ L of media per well into a white-walled 96-well plate.
 - Incubate for 24 hours.
 - Treat the cells with various concentrations of Compound X for 24 to 48 hours. Include a positive control (e.g., staurosporine) and a vehicle control.[8]
- Assay Procedure:
 - Equilibrate the plate and the Caspase-Glo® 3/7 Reagent to room temperature.
 - Add 100 μ L of the Caspase-Glo® 3/7 Reagent to each well.[9]
 - Mix the contents of the wells by gentle shaking for 30 seconds.
 - Incubate the plate at room temperature for 1-2 hours, protected from light.[10]
- Measurement and Analysis:
 - Measure the luminescence of each well using a plate-reading luminometer.
 - Calculate the fold change in caspase activity relative to the vehicle-treated control.

Data Presentation

Table 1: Cell Viability (IC50) of Compound X in Various Cancer Cell Lines

Cell Line	Cancer Type	IC50 (μM)
Hec50co	Endometrial	0.5
A549	Lung	1.2
U87MG	Glioblastoma	2.5
MDA-MB-231	Breast	5.8

Table 2: Effect of Compound X on ERK Phosphorylation in Hec50co Cells

Treatment	p-ERK1/2 (Relative Density)	Total ERK1/2 (Relative Density)	p-ERK/Total ERK Ratio
Vehicle Control	1.00	1.00	1.00
Compound X (0.1 μM)	0.45	0.98	0.46
Compound X (1 μM)	0.12	1.02	0.12
Compound X (10 μM)	0.02	0.99	0.02

Table 3: Induction of Apoptosis by Compound X in Hec50co Cells

Treatment	Caspase-3/7 Activity (Fold Change vs. Control)
Vehicle Control	1.0
Compound X (1 μM)	3.5
Compound X (10 μM)	8.2
Staurosporine (1 μM)	10.5

Signaling Pathway and Experimental Workflows

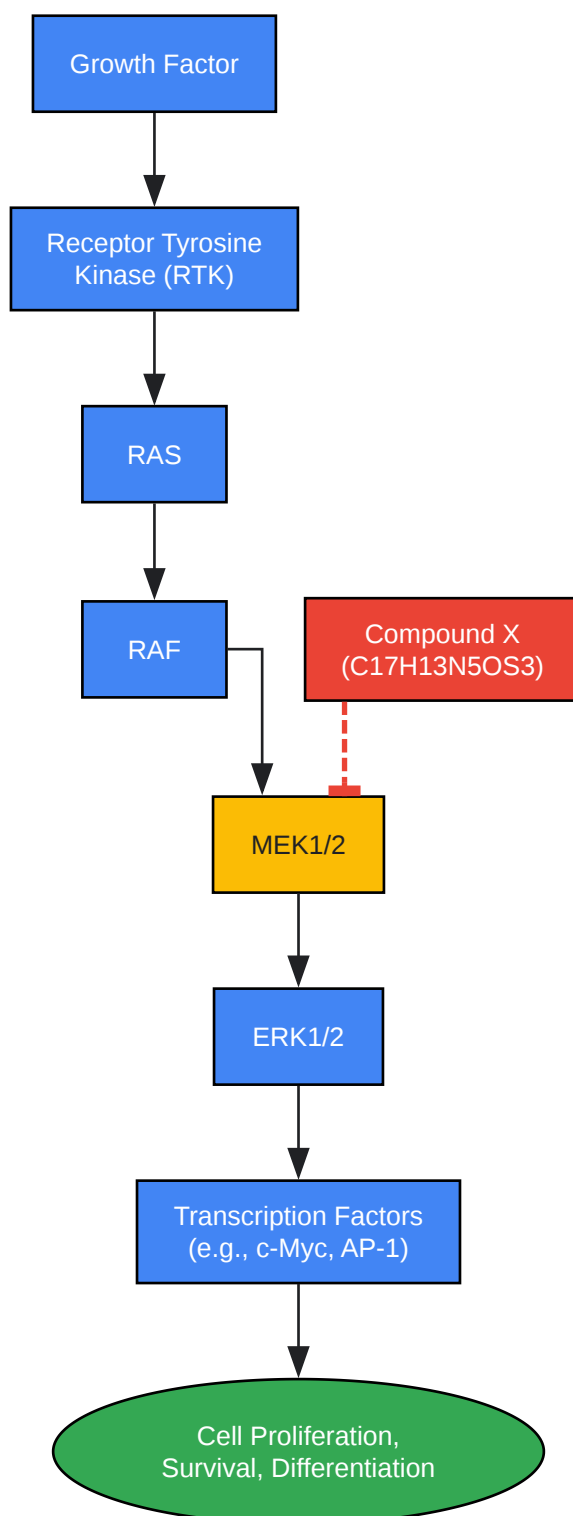

[Click to download full resolution via product page](#)

Caption: MAPK/ERK signaling pathway with the inhibitory action of Compound X on MEK1/2.

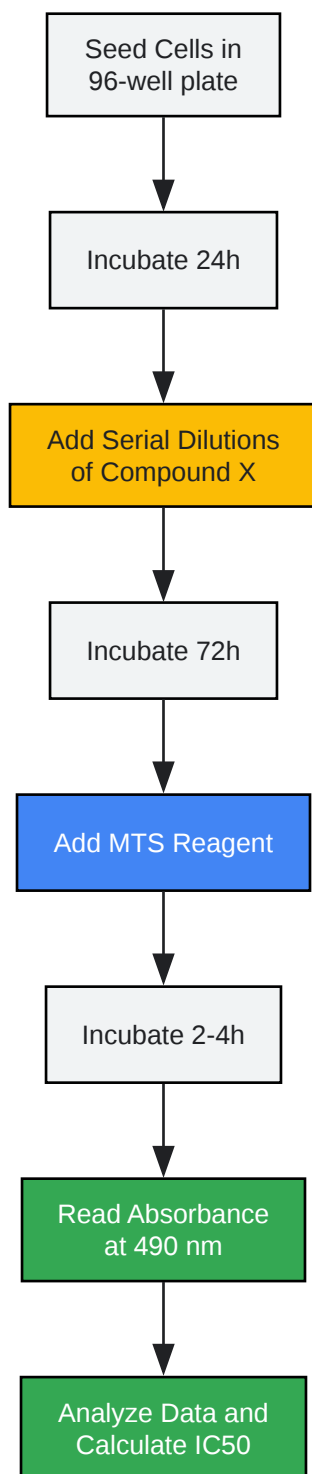

[Click to download full resolution via product page](#)

Caption: Experimental workflow for the cell viability (MTS) assay.

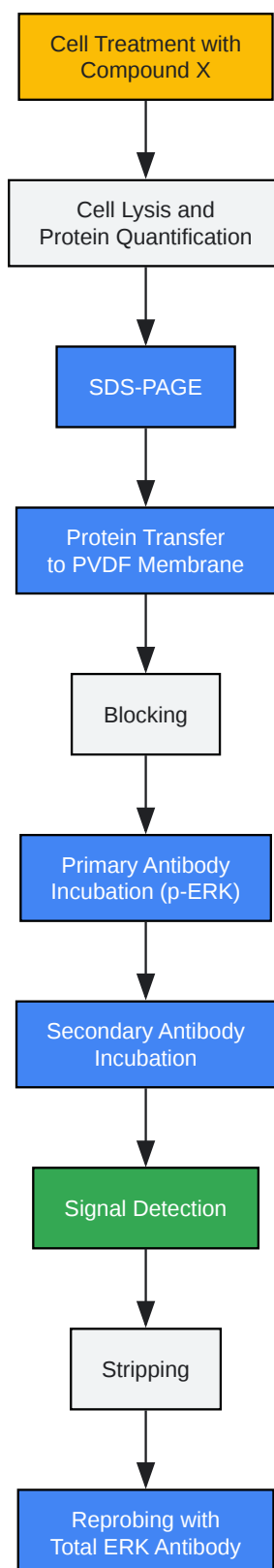

[Click to download full resolution via product page](#)

Caption: Experimental workflow for Western blot analysis of p-ERK and total ERK.

Need Custom Synthesis?

BenchChem offers custom synthesis for rare earth carbides and specific isotopic labeling.

Email: info@benchchem.com or [Request Quote Online](#).

References

- 1. Establishment of a novel method to assess MEK1/2 inhibition in PBMCs for clinical drug development - PMC [[pmc.ncbi.nlm.nih.gov](https://pubmed.ncbi.nlm.nih.gov/)]
- 2. The MEK 1/2 Inhibitor PD98059 Exhibits Synergistic Anti-endometrial Cancer Activity with Paclitaxel in vitro and Enhanced Tissue Distribution in vivo when Formulated into PAMAM-coated PLGA-PEG Nanoparticles - PMC [[pmc.ncbi.nlm.nih.gov](https://pubmed.ncbi.nlm.nih.gov/)]
- 3. tools.thermofisher.com [tools.thermofisher.com]
- 4. Measuring agonist-induced ERK MAP kinase phosphorylation for G-protein-coupled receptors - PMC [[pmc.ncbi.nlm.nih.gov](https://pubmed.ncbi.nlm.nih.gov/)]
- 5. Phospho-ERK1/2 (Thr202/Tyr204) antibody (80031-1-RR) | Proteintech [[ptglab.com](https://www.proteintech.com/)]
- 6. [dbbiotech.com](https://www.dbbiotech.com) [[dbbiotech.com](https://www.dbbiotech.com)]
- 7. [researchgate.net](https://www.researchgate.net) [[researchgate.net](https://www.researchgate.net)]
- 8. [tandfonline.com](https://www.tandfonline.com) [[tandfonline.com](https://www.tandfonline.com)]
- 9. Caspase-Glo® 3/7 Assay Protocol [[worldwide.promega.com](https://www.promega.com/worldwide)]
- 10. [moleculardevices.com](https://www.moleculardevices.com) [[moleculardevices.com](https://www.moleculardevices.com)]
- To cite this document: BenchChem. [Application Notes and Protocols for C17H13N5OS3 (Compound X)]. BenchChem, [2026]. [Online PDF]. Available at: [<https://www.benchchem.com/product/b15174265/docs#application-notes-and-protocols-for-c17h13n5os3-compound-x>]

Disclaimer & Data Validity:

The information provided in this document is for Research Use Only (RUO) and is strictly not intended for diagnostic or therapeutic procedures. While BenchChem strives to provide accurate protocols, we make no warranties, express or implied, regarding the fitness of this product for every specific experimental setup.

Technical Support: The protocols provided are for reference purposes. Unsure if this reagent suits your experiment?

Need Industrial/Bulk Grade? [Request Custom Synthesis Quote](#)

BenchChem

Our mission is to be the trusted global source of essential and advanced chemicals, empowering scientists and researchers to drive progress in science and industry.

Contact

Address: 3281 E Guasti Rd
Ontario, CA 91761, United States
Phone: (601) 213-4426
Email: info@benchchem.com

[Contact our Ph.D. Support Team for a compatibility check](#)