

# Application Note: Advanced Derivatization Strategies for 2-[(3-Fluorophenyl)sulfonyl]pyridine

**Author:** BenchChem Technical Support Team. **Date:** May 2026

## Compound of Interest

Compound Name:	2-[(3-Fluorophenyl)sulfonyl]pyridine
CAS No.:	950693-98-8
Cat. No.:	B15172099

[Get Quote](#)

## Abstract

The **2-[(3-fluorophenyl)sulfonyl]pyridine** scaffold represents a privileged structural motif in medicinal chemistry, serving as both a robust pharmacophore (e.g., in 11 $\beta$ -HSD1 inhibitors) and a tunable "covalent warhead" for cysteine targeting. This guide details high-fidelity protocols for creating derivatives of this scaffold. We move beyond basic synthesis to explore regioselective late-stage functionalization (LSF) and modular construction, enabling the rapid generation of structure-activity relationship (SAR) libraries.

## Structural Analysis & Reactivity Profile

Before attempting derivatization, one must understand the electronic landscape of the molecule. The sulfonyl linker (

) acts as a potent electron-withdrawing group (EWG), dramatically altering the reactivity of both aromatic rings.

## Reactivity Hotspots

- Pyridine Ring (Electron Deficient):
  - C4 Position: Highly activated for radical attack (Minisci reaction).
  - C6 Position: Accessible via N-oxide activation (Reissert-Henze type).
  - C2 Position: The sulfonyl group is a potential leaving group ( ) if treated with strong nucleophiles, allowing "scaffold hopping."
- Phenyl Ring (Electron Richer but Deactivated):
  - C2' Position (Between F and SO<sub>2</sub>): The "sweet spot" for Directed Ortho Metalation (DoM). The acidity of this proton is synergistically enhanced by the inductive effects of both the fluorine and the sulfonyl group.
  - C4'/C6' Positions: Secondary sites for electrophilic substitution or lithiation, depending on steric blocking at C2'.

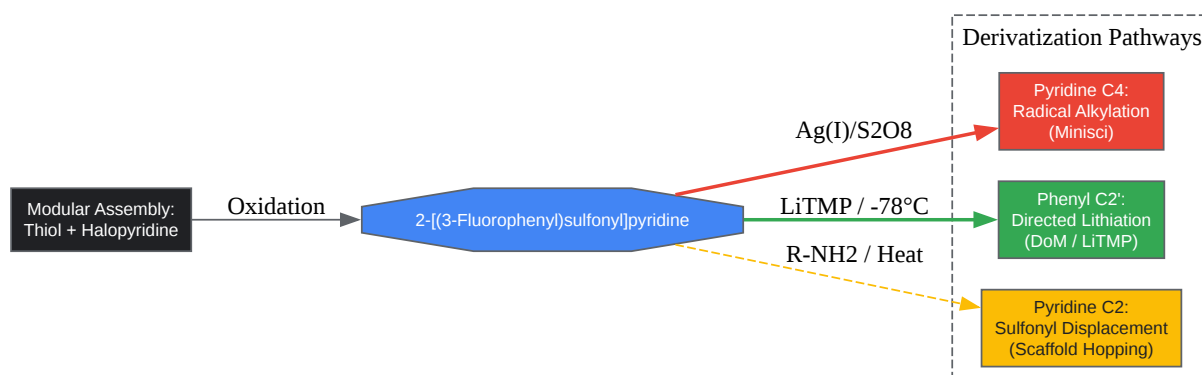

[Click to download full resolution via product page](#)

Figure 1: Reactivity map illustrating the primary vectors for functionalizing the scaffold.

## Module 1: Modular De Novo Synthesis (The "Build" Phase)

Best for: Creating libraries with deep structural changes (e.g., replacing the pyridine core or altering the phenyl substitution pattern).

The most reliable method to generate derivatives is to assemble the sulfone from modified precursors. This avoids the selectivity issues of late-stage functionalization.

### Protocol A: Coupling & Oxidation

This two-step sequence is the industry standard for scalability and reliability.

#### Step 1: Sulfide Formation

- Reagents: 2-Chloropyridine (1.0 equiv), 3-Fluorobenzenethiol (1.1 equiv),  
(1.5 equiv).
- Solvent: DMF or DMSO (0.5 M).
- Conditions: Heat to 80–100 °C for 4–6 hours under  
.
- Workup: Dilute with water, extract with EtOAc. The sulfide intermediate is often pure enough for the next step.

#### Step 2: Oxidation to Sulfone

- Reagents: Sulfide intermediate (1.0 equiv), mCPBA (2.2–2.5 equiv) OR  
(30%) /  
(cat.).
- Solvent: DCM (for mCPBA) or EtOH/Acetic Acid (for  
).

- Conditions: Stir at 0 °C to RT for 2–12 hours.
- Purification: Quench mCPBA with saturated  
. Wash with  
. Recrystallize from EtOH/Hexane if necessary.

Table 1: Modular Component Selection

Desired Derivative Type	Recommended Precursor 1 (Electrophile)	Recommended Precursor 2 (Nucleophile)
Standard Scaffold	<b>2-Chloropyridine</b>	<b>3-Fluorobenzenethiol</b>
Pyridine-Substituted	2-Chloro-4-methylpyridine	3-Fluorobenzenethiol
Phenyl-Substituted	2-Chloropyridine	3-Fluoro-4-bromobenzenethiol

| Aza-Variant | 2-Chloropyrimidine | 3-Fluorobenzenethiol |

## Module 2: Late-Stage Pyridine Functionalization

Best for: Adding alkyl groups to the pyridine ring without re-synthesizing the core.

### Protocol B: C4-Selective Minisci Alkylation

The Minisci reaction utilizes carbon-centered radicals to alkylate the electron-deficient pyridine ring. Due to the blocking effect of the sulfonyl group at C2, this reaction is highly selective for the C4 position.

Mechanism: Oxidative decarboxylation of a carboxylic acid generates an alkyl radical, which attacks the protonated pyridine.

Experimental Workflow:

- Setup: Dissolve **2-[(3-fluorophenyl)sulfonyl]pyridine** (1.0 equiv) in a biphasic mixture of DCM and water (1:1) or neat TFA (if substrate is stable).

- Radical Source: Add the desired Carboxylic Acid (R-COOH, 2.0–3.0 equiv).
- Catalyst/Oxidant: Add  
(0.2 equiv) and  
(3.0 equiv).
- Reaction: Heat to 40–60 °C with vigorous stirring for 2–4 hours. Note: Evolution of gas will occur.
- Workup: Basify carefully with NaOH (keep cool) to pH >9. Extract with DCM.[1][2]
- Purification: Flash chromatography (often required to separate mono-alkylated product from traces of bis-alkylated byproducts).

Critical Note: For volatile alkyl groups (methyl, ethyl), use the corresponding sodium sulfinates (Langlois reagent) or tert-butyl peresters instead of carboxylic acids for better yields.

## Module 3: Late-Stage Phenyl Functionalization

Best for: Introducing halogens, formyl groups, or boronic esters to the phenyl ring.

### Protocol C: Directed Ortho Metalation (DoM)

The sulfonyl group is a powerful Directed Metalation Group (DMG). The 3-fluoro substituent is also a DMG.[3] Their combined directing effects make the C2' position (the carbon between the sulfonyl and fluorine) the most acidic and kinetically accessible site.

Warning: n-Butyllithium (n-BuLi) can attack the pyridine ring (nucleophilic addition) rather than acting as a base. Lithium Tetramethylpiperidide (LiTMP) is mandatory here as a non-nucleophilic, bulky base.

Experimental Workflow:

- Preparation of LiTMP: To a solution of 2,2,6,6-tetramethylpiperidine (1.2 equiv) in anhydrous THF at -78 °C, add n-BuLi (1.1 equiv). Stir for 30 min at 0 °C, then cool back to -78 °C.

- Substrate Addition: Add solution of **2-[(3-fluorophenyl)sulfonyl]pyridine** (1.0 equiv) in THF dropwise to the LiTMP solution at -78 °C.
  - Observation: The solution often turns deep red/orange (formation of the lithiated species).
- Metalation: Stir at -78 °C for 45–60 minutes. Do not warm up, or the "Snieckus rearrangement" (migration of the sulfonyl group) may occur.
- Electrophile Trapping: Add the electrophile (1.5 equiv) dissolved in THF.
  - Electrophiles:[\[4\]](#)[\[5\]](#)  
(for iodides), DMF (for aldehydes),  
(for boronic acids).
- Quench: Warm to RT and quench with saturated

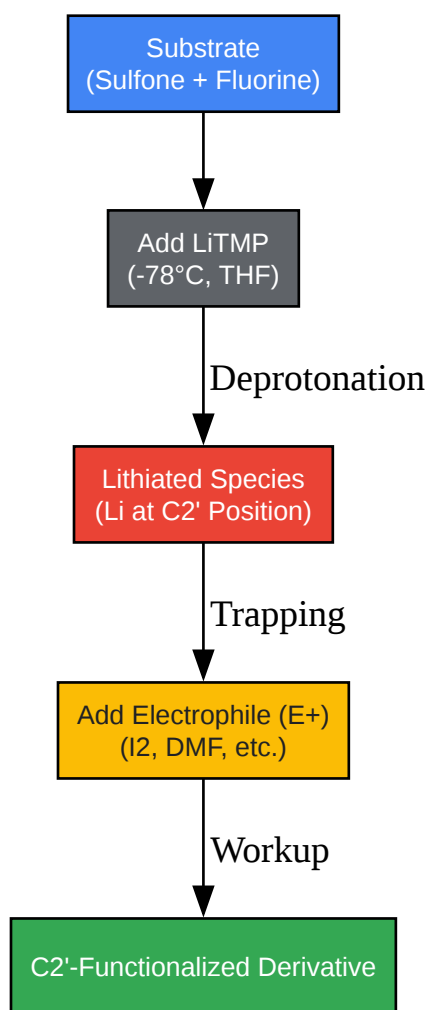

[Click to download full resolution via product page](#)

Figure 2: Workflow for the regioselective C2' functionalization via DoM.

## References

- Minisci Reaction on Pyridines: Duncton, M. A. J. (2011). Minisci reactions: Versatile CH-functionalizations for medicinal chemists. *Med.[6][7][8] Chem. Commun.*, 2, 1135-1161. [Link](#)
- Directed Ortho Metalation (DoM) Review: Snieckus, V. (1990). Directed ortho metalation. Tertiary amide and O-carbamate directors in synthetic strategies for polysubstituted aromatics. *Chem. Rev.*, 90(6), 879–933. [Link](#)
- Sulfonyl Pyridines as Warheads: Hatcher, J. M., et al. (2020). 2-Sulfonyl pyridines as tunable, cysteine-reactive electrophiles. *Cell Chem. Biol.*, 27(12), 1530-1541. [Link](#)

- Regioselectivity in Pyridine Lithiation: Schlosser, M., & Rausis, T. (2004). Site-Selective Derivatization of 2-, 3-, and 4-Chloropyridines. *Eur. J. Org. Chem.*, 2004(5), 1018–1024. [Link](#)

### Need Custom Synthesis?

BenchChem offers custom synthesis for rare earth carbides and specific isotopic labeling.

Email: [info@benchchem.com](mailto:info@benchchem.com) or [Request Quote Online](#).

## Sources

- [1. pdf.benchchem.com \[pdf.benchchem.com\]](https://pdf.benchchem.com)
- [2. Practical and Regioselective Synthesis of C-4-Alkylated Pyridines \[organic-chemistry.org\]](#)
- [3. triggered.stanford.clockss.org \[triggered.stanford.clockss.org\]](https://triggered.stanford.clockss.org)
- [4. Regioselective difunctionalization of pyridines via 3,4-pyridynes - PMC \[pmc.ncbi.nlm.nih.gov\]](#)
- [5. pdfs.semanticscholar.org \[pdfs.semanticscholar.org\]](https://pdfs.semanticscholar.org)
- [6. researchgate.net \[researchgate.net\]](https://researchgate.net)
- [7. preprints.org \[preprints.org\]](https://preprints.org)
- [8. preprints.org \[preprints.org\]](https://preprints.org)
- To cite this document: BenchChem. [Application Note: Advanced Derivatization Strategies for 2-[(3-Fluorophenyl)sulfonyl]pyridine]. BenchChem, [2026]. [Online PDF]. Available at: [\[https://www.benchchem.com/product/b15172099/docs#application-note-advanced-derivatization-strategies-for-2-3-fluorophenyl-sulfonyl-pyridine\]](https://www.benchchem.com/product/b15172099/docs#application-note-advanced-derivatization-strategies-for-2-3-fluorophenyl-sulfonyl-pyridine)

---

### Disclaimer & Data Validity:

The information provided in this document is for Research Use Only (RUO) and is strictly not intended for diagnostic or therapeutic procedures. While BenchChem strives to provide accurate protocols, we make no warranties, express or implied, regarding the fitness of this product for every specific experimental setup.

**Technical Support:** The protocols provided are for reference purposes. Unsure if this reagent suits your experiment?

**Need Industrial/Bulk Grade?** [Request Custom Synthesis Quote](#)

## BenchChem

Our mission is to be the trusted global source of essential and advanced chemicals, empowering scientists and researchers to drive progress in science and industry.

### Contact

Address: 3281 E Guasti Rd  
Ontario, CA 91761, United States  
Phone: (601) 213-4426  
Email: [info@benchchem.com](mailto:info@benchchem.com)

[Contact our Ph.D. Support Team for a compatibility check](#)