

Technical Support Center: Optimizing Base Selection for Morpholine Derivative Synthesis

Author: BenchChem Technical Support Team. **Date:** May 2026

Compound of Interest

Compound Name: 2-(3-Bromophenyl)morpholine

CAS No.: 1018612-02-6

Cat. No.: B1517816

[Get Quote](#)

Ticket ID: MORPH-OPT-2024 Status: Open Assigned Specialist: Senior Application Scientist
Subject: Base Selection Strategy for Yield Optimization & Impurity Control

Executive Summary: The Base Selection Matrix

In morpholine synthesis, the base is not merely a proton scavenger; it is a kinetic switch that controls the rate-determining step (RDS) and solubility parameters. The choice of base must be matched to the reaction mechanism (SN2, SNAr, or Pd-Catalyzed Cross-Coupling) and the pKa of the specific morpholine intermediate.

Quick Reference: Base Selection Decision Tree

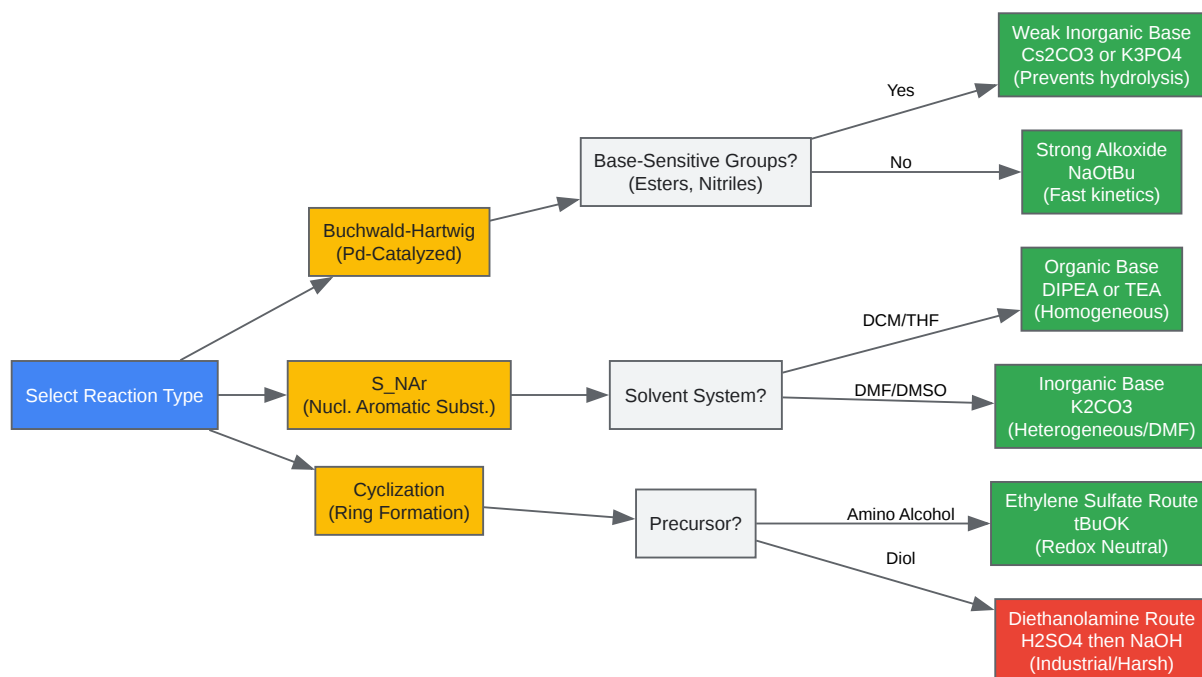

[Click to download full resolution via product page](#)

Figure 1: Decision matrix for selecting the optimal base based on reaction mechanism and substrate sensitivity.

Technical Deep Dive: Mechanism & Causality

Module A: Buchwald-Hartwig Amination

The Challenge: Morpholine is a secondary amine with moderate steric bulk. In Pd-catalyzed coupling, the base plays a dual role:

- Deprotonation: It must deprotonate the Pd(II)-amine complex to facilitate reductive elimination.
- Coordination Management: It must not bind too strongly to the Pd center, which would poison the catalyst.

Scientific Rationale:

- NaOtBu (Sodium tert-butoxide): The gold standard for non-sensitive substrates. Its bulky tert-butyl group prevents it from coordinating to the Pd metal center, leaving the active site open for the morpholine amine. However, its high basicity (pKa ~17 in H₂O, much higher in organic solvents) can hydrolyze esters or enolize ketones.
- Cs₂CO₃ (Cesium Carbonate): Essential for functionalized substrates. The "Cesium Effect" is real: the large ionic radius of Cs⁺ makes the carbonate anion more "naked" and soluble in organic solvents like Toluene or Dioxane compared to K₂CO₃, enhancing reactivity without the harshness of alkoxides [1].

Module B: Green Cyclization (Ethylene Sulfate)

The Challenge: Traditional cyclization from diethanolamine requires harsh acidic dehydration (H₂SO₄ at >150°C). The Solution: A redox-neutral SN₂ cascade using tBuOK. Mechanism: Potassium tert-butoxide acts as a strong, non-nucleophilic base. It promotes the initial attack of the amine on ethylene sulfate and the subsequent intramolecular ring closure. The bulky cation (K⁺) and anion (tBuO⁻) minimize competing nucleophilic attacks on the sulfate sulfur [2].

Optimized Protocols

Protocol 1: Buchwald-Hartwig Coupling of Morpholine

Best for: Attaching morpholine to aryl halides (Cl, Br, I).[1]

Reagents:

- Aryl Halide (1.0 equiv)
- Morpholine (1.2 equiv)
- Base: NaOtBu (1.4 equiv) [Use Cs₂CO₃ (2.0 equiv) if substrate has esters]
- Catalyst: Pd(OAc)₂ (1-2 mol%)
- Ligand: BINAP or XPhos (2-4 mol%)
- Solvent: Toluene (anhydrous)

Step-by-Step:

- Inerting: Charge reaction vessel with Aryl Halide, NaOtBu, Pd(OAc)₂, and Ligand. Purge with N₂/Ar x3. Note: Oxygen kills the active Pd(0) species.
- Addition: Add Toluene and Morpholine via syringe.
- Heating: Heat to 80-100°C.
 - Technical Insight: If using Cs₂CO₃, ensure vigorous stirring (1000 rpm). The reaction is heterogeneous, and rate is limited by surface area contact between the solid base and the liquid phase.
- Workup: Cool, filter through Celite (removes Pd black and inorganic salts), and concentrate.

Protocol 2: Green Synthesis from Amino Alcohols

Best for: Creating the morpholine ring from scratch (De novo synthesis).

Reagents:

- Amino Alcohol (1.0 equiv)
- Ethylene Sulfate (1.0 equiv)
- Base: tBuOK (2.5 equiv)
- Solvent: THF or DCM

Step-by-Step:

- Dissolve amino alcohol in dry THF at 0°C.
- Add Ethylene Sulfate portion-wise.
- Add tBuOK slowly. Caution: Exothermic.
- Allow to warm to Room Temperature (RT) and stir for 4-12 hours.

- Validation: Monitor by TLC. The disappearance of the cyclic sulfate intermediate indicates completion.

Troubleshooting & FAQ

Q1: My Buchwald reaction stalled at 50% conversion. Adding more base didn't help.

Diagnosis: Catalyst Poisoning or Iodide Inhibition.[2] Explanation: If you are using Aryl Iodides, the released Iodide ions (I^-) can bridge two Palladium centers, forming an inactive dimer.

Solution:

- Switch to Aryl Bromides (Br^- is less inhibitory).
- If you must use Iodides, switch the base to KOH or add a silver salt ($AgOTf$) to precipitate the iodide, though this is expensive. A more practical fix is increasing the ligand: Pd ratio to 2:1 or 3:1 to protect the metal center [3].

Q2: I see a lot of "Pd-Black" precipitating out. What does this mean?

Diagnosis: Catalyst decomposition. Cause: The ligand is detaching from the Palladium, leading to aggregation of Pd(0) into inactive metal clusters. Base Factor: Strong bases like NaOtBu can sometimes promote this if the ligand is not bulky enough. Fix:

- Switch to a phosphine ligand with higher steric bulk (e.g., XPhos or BrettPhos).
- Ensure your solvent is strictly anhydrous; water + strong base = hydroxide, which can displace ligands.

Q3: In S_NAr reactions, when should I use DIPEA vs. K_2CO_3 ?

Guidance:

- Use DIPEA (Organic Base): When using non-polar solvents (DCM, THF) or when the reaction must remain homogeneous. DIPEA acts as a proton sponge but is non-nucleophilic

due to steric hindrance.

- Use K_2CO_3 (Inorganic Base): When using polar aprotic solvents (DMF, DMSO). K_2CO_3 is poorly soluble in DCM but works excellently in DMF. It is generally cheaper and easier to remove (water wash) than organic amine salts.

Data Comparison: Base Effectiveness

Table 1: Comparison of bases in the N-arylation of Morpholine with 4-bromoanisole (Model System).

| Base | pKa (Conj.[3] Acid) | Yield (%) | Reaction Time | Notes |
|---------------------------------|--------------------------|-----------|---------------|--|
| NaOtBu | ~17 (H ₂ O) | 95% | 4 h | Best for inert substrates. Fast kinetics. |
| Cs ₂ CO ₃ | 10.3 (H ₂ O) | 88% | 12 h | Excellent functional group tolerance. Requires heating. |
| K ₃ PO ₃ | 12.3 (H ₂ O) | 82% | 16 h | Good alternative to Cs ₂ CO ₃ if cost is a factor. |
| DBU | 12.0 (H ₂ O) | <10% | 24 h | Avoid. Coordinates to Pd, inhibiting the catalytic cycle [4]. |
| DIPEA | 10.75 (H ₂ O) | <5% | 24 h | Ineffective for Pd-coupling; cannot deprotonate Pd-complex efficiently. |

References

- Vertex AI Search. (2025). Role of the base in Buchwald-Hartwig amination. ResearchGate. [4](#)
- Ortiz, K. G., et al. (2024).[\[5\]](#) Green Synthesis of Morpholines via Selective Monoalkylation of Amines. ChemRxiv. [6\[3\]\[7\]\[8\]\[4\]](#)
- WuXi AppTec. (2025).[\[3\]](#) How to Wisely Design Conditions for Buchwald-Hartwig Couplings?. [2\[3\]\[1\]\[9\]\[7\]\[8\]\[4\]\[10\]\[11\]](#)
- McGowan, M. A., et al. (2014). Pd-Catalyzed Amination: Base Selection. Organometallics. [9](#)

Need Custom Synthesis?

BenchChem offers custom synthesis for rare earth carbides and specific isotopic labeling.

Email: info@benchchem.com or [Request Quote Online](#).

Sources

- [1. pdf.benchchem.com](https://pdf.benchchem.com) [pdf.benchchem.com]
- [2. Chemical Insights | How to Wisely Design Conditions for Buchwald-Hartwig Couplings ? - RCS Research Chemistry Services](#) [rcs.wuxiapptec.com]
- [3. researchgate.net](#) [researchgate.net]
- [4. researchgate.net](#) [researchgate.net]
- [5. Morpholine synthesis](#) [organic-chemistry.org]
- [6. chemrxiv.org](#) [chemrxiv.org]
- [7. researchgate.net](#) [researchgate.net]
- [8. researchgate.net](#) [researchgate.net]
- [9. pubs.acs.org](#) [pubs.acs.org]
- [10. pubs.acs.org](#) [pubs.acs.org]
- [11. Role of the base in Buchwald-Hartwig amination - PubMed](#) [pubmed.ncbi.nlm.nih.gov]
- To cite this document: BenchChem. [Technical Support Center: Optimizing Base Selection for Morpholine Derivative Synthesis]. BenchChem, [2026]. [Online PDF]. Available at:

[\[https://www.benchchem.com/product/b1517816/docs#technical-support-center-optimizing-base-selection-for-morpholine-derivative-synthesis\]](https://www.benchchem.com/product/b1517816/docs#technical-support-center-optimizing-base-selection-for-morpholine-derivative-synthesis)

Disclaimer & Data Validity:

The information provided in this document is for Research Use Only (RUO) and is strictly not intended for diagnostic or therapeutic procedures. While BenchChem strives to provide accurate protocols, we make no warranties, express or implied, regarding the fitness of this product for every specific experimental setup.

Technical Support: The protocols provided are for reference purposes. Unsure if this reagent suits your experiment?

Need Industrial/Bulk Grade? [Request Custom Synthesis Quote](#)

BenchChem

Our mission is to be the trusted global source of essential and advanced chemicals, empowering scientists and researchers to drive progress in science and industry.

Contact

Address: 3281 E Guasti Rd
Ontario, CA 91761, United States
Phone: (601) 213-4426
Email: info@benchchem.com

[Contact our Ph.D. Support Team for a compatibility check](#)