

Validating EGFR Target Engagement in Cells: A Comparative Guide

Author: BenchChem Technical Support Team. **Date:** April 2026

Compound of Interest

Compound Name: EGFR-IN-145

Cat. No.: B10805567

[Get Quote](#)

For Researchers, Scientists, and Drug Development Professionals

This guide provides a comparative overview of methodologies to validate the cellular target engagement of Epidermal Growth Factor Receptor (EGFR) inhibitors. As specific data for "EGFR-IN-145" is not publicly available, this document uses the third-generation inhibitor Osimertinib as a primary example and compares its performance with the first-generation inhibitor Gefitinib and the second-generation inhibitor Afatinib.

Introduction to EGFR and Targeted Inhibition

The Epidermal Growth Factor Receptor (EGFR) is a receptor tyrosine kinase that plays a critical role in regulating cell proliferation, survival, and differentiation.[1] Dysregulation of the EGFR signaling pathway is a key driver in the development and progression of various cancers.[1] EGFR inhibitors are a class of therapeutic agents designed to block the kinase activity of the receptor, thereby inhibiting downstream signaling and inducing cancer cell death. These inhibitors are broadly classified into three generations based on their mechanism of action and specificity for different EGFR mutations.

- First-Generation (e.g., Gefitinib): Reversible inhibitors of the EGFR tyrosine kinase.

- Second-Generation (e.g., Afatinib): Irreversible covalent inhibitors that target EGFR and other ErbB family members.
- Third-Generation (e.g., Osimertinib): Irreversible covalent inhibitors designed to be selective for both sensitizing EGFR mutations and the T790M resistance mutation, while sparing wild-type EGFR.[2]

Comparative Analysis of EGFR Inhibitors

This section provides a quantitative comparison of Osimertinib, Gefitinib, and Afatinib based on their half-maximal inhibitory concentrations (IC50) in various cell lines with different EGFR mutation statuses.

Inhibitor (Generation)	Cell Line	EGFR Mutation Status	IC50 (nM)
Osimertinib (3rd)	Ba/F3	Wild-Type	~500
Ba/F3	L858R/T790M	~11.4	
Ba/F3	Exon 19 deletion	~12.9	
Gefitinib (1st)	NR6wtEGFR	Wild-Type	37
NR6W	Wild-Type	57	
PC-9	Exon 19 deletion	-	
Afatinib (2nd)	Ba/F3	Wild-Type	31
H3255	L858R	-	
11-18	L858R	-	

Note: IC50 values can vary depending on the specific experimental conditions and cell lines used. The data presented here is a compilation from multiple sources for comparative purposes.[2][3]

Experimental Protocols for Target Engagement Validation

Validating that a compound engages its intended target within a cellular context is a critical step in drug development. The following are key experimental protocols used to confirm the cellular target engagement of EGFR inhibitors.

Cellular Thermal Shift Assay (CETSA)

The Cellular Thermal Shift Assay (CETSA) is a powerful technique to directly assess the binding of a drug to its target protein in a cellular environment. The principle is based on the ligand-induced thermal stabilization of the target protein.

Experimental Protocol:

- **Cell Treatment:** Treat cultured cells with the EGFR inhibitor at various concentrations or with a vehicle control.
- **Heating:** Heat the cell suspensions at a range of temperatures.
- **Cell Lysis:** Lyse the cells to release the proteins.
- **Separation of Aggregated Proteins:** Centrifuge the lysates to pellet the aggregated, denatured proteins.
- **Quantification of Soluble Protein:** Collect the supernatant containing the soluble proteins and quantify the amount of EGFR using methods like Western blotting or ELISA.
- **Data Analysis:** Plot the amount of soluble EGFR as a function of temperature. A shift in the melting curve to a higher temperature in the presence of the inhibitor indicates target engagement.

While direct comparative CETSA data for Osimertinib, Gefitinib, and Afatinib is not readily available in the public domain, the principle of the assay remains a gold standard for confirming target engagement.

Western Blot Analysis of Downstream Signaling

Inhibition of EGFR's kinase activity should lead to a reduction in the phosphorylation of EGFR itself (autophosphorylation) and key downstream signaling proteins such as Akt and ERK.

Experimental Protocol:

- **Cell Culture and Treatment:** Plate cells and, once attached, serum-starve them to reduce basal signaling. Treat the cells with the EGFR inhibitor at various concentrations for a specified time.
- **EGF Stimulation:** Stimulate the cells with Epidermal Growth Factor (EGF) to induce EGFR phosphorylation.
- **Cell Lysis:** Wash the cells with ice-cold PBS and lyse them using a suitable lysis buffer containing protease and phosphatase inhibitors.
- **Protein Quantification:** Determine the protein concentration of the cell lysates.
- **SDS-PAGE and Western Blotting:**
 - Separate the protein lysates by SDS-PAGE and transfer them to a PVDF membrane.
 - Block the membrane and incubate with primary antibodies against total EGFR, phosphorylated EGFR (p-EGFR), total Akt, phosphorylated Akt (p-Akt), total ERK, and phosphorylated ERK (p-ERK).
 - Incubate with the appropriate HRP-conjugated secondary antibodies.
 - Visualize the protein bands using a chemiluminescence detection system.
- **Data Analysis:** Quantify the band intensities and normalize the levels of phosphorylated proteins to the total protein levels to determine the extent of inhibition.

Cell Viability Assay (MTT Assay)

This assay indirectly assesses target engagement by measuring the biological consequence of EGFR inhibition, which is a reduction in cell viability and proliferation in EGFR-dependent cancer cell lines.

Experimental Protocol:

- **Cell Seeding:** Seed cancer cells in a 96-well plate and allow them to attach overnight.

- Inhibitor Treatment: Treat the cells with a serial dilution of the EGFR inhibitor.
- Incubation: Incubate the cells for 48-72 hours.
- MTT Addition: Add MTT (3-(4,5-dimethylthiazol-2-yl)-2,5-diphenyltetrazolium bromide) solution to each well and incubate for 2-4 hours. Live cells will reduce the yellow MTT to purple formazan crystals.
- Solubilization: Add a solubilization solution (e.g., DMSO) to dissolve the formazan crystals.
- Absorbance Measurement: Measure the absorbance at a wavelength of 570 nm.
- Data Analysis: Plot the cell viability against the inhibitor concentration to determine the IC50 value.

Visualizing Pathways and Workflows

EGFR Signaling Pathway and Inhibition

The following diagram illustrates the EGFR signaling cascade and the points of inhibition by tyrosine kinase inhibitors (TKIs).

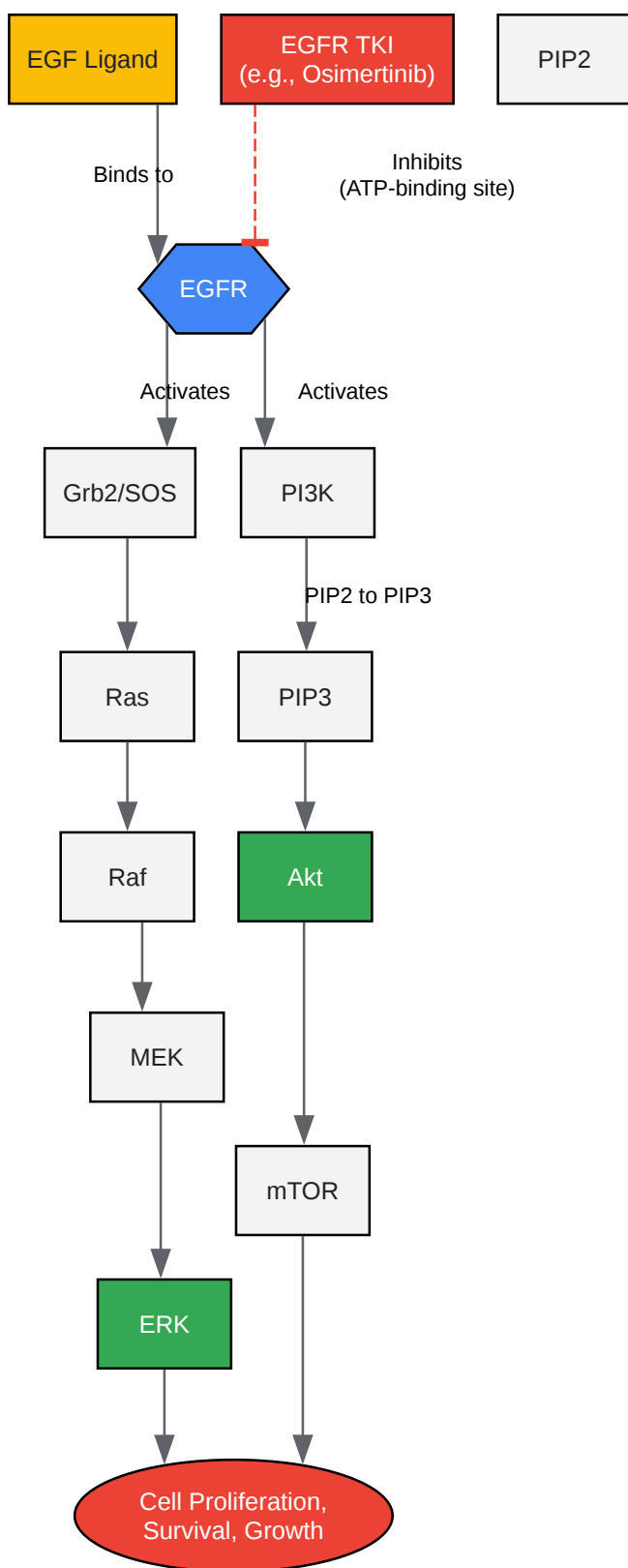

[Click to download full resolution via product page](#)

Caption: EGFR signaling pathway and the point of inhibition by TKIs.

Experimental Workflow for Target Engagement Validation

The following diagram outlines a general workflow for validating the cellular target engagement of an EGFR inhibitor.

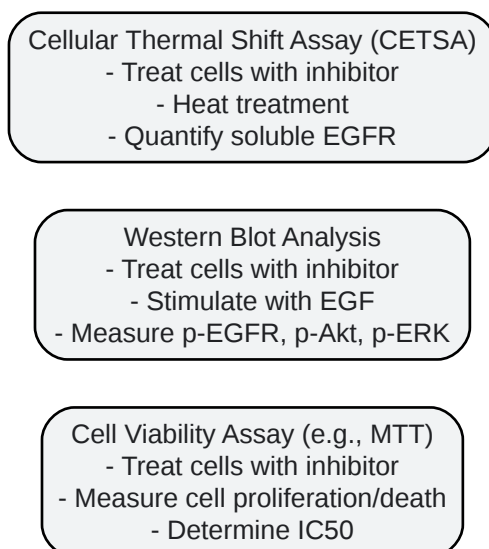

[Click to download full resolution via product page](#)

Caption: Workflow for validating EGFR inhibitor target engagement.

Need Custom Synthesis?

BenchChem offers custom synthesis for rare earth carbides and specific isotopic labeling.

Email: info@benchchem.com or [Request Quote Online](#).

References

- [1. researchgate.net \[researchgate.net\]](https://www.researchgate.net)
- [2. In vitro modeling to determine mutation specificity of EGFR tyrosine kinase inhibitors against clinically relevant EGFR mutants in non-small-cell lung cancer - PMC \[pmc.ncbi.nlm.nih.gov\]](https://pubmed.ncbi.nlm.nih.gov/)
- [3. scispace.com \[scispace.com\]](https://www.scispace.com)

- To cite this document: BenchChem. [Validating EGFR Target Engagement in Cells: A Comparative Guide]. BenchChem, [2026]. [Online PDF]. Available at: [<https://www.benchchem.com/product/b10805567/docs#validating-egfr-target-engagement-in-cells-a-comparative-guide>]

Disclaimer & Data Validity:

The information provided in this document is for Research Use Only (RUO) and is strictly not intended for diagnostic or therapeutic procedures. While BenchChem strives to provide accurate protocols, we make no warranties, express or implied, regarding the fitness of this product for every specific experimental setup.

Technical Support: The protocols provided are for reference purposes. Unsure if this reagent suits your experiment?

Need Industrial/Bulk Grade? [Request Custom Synthesis Quote](#)

BenchChem

Our mission is to be the trusted global source of essential and advanced chemicals, empowering scientists and researchers to drive progress in science and industry.

Contact

Address: 3281 E Guasti Rd
Ontario, CA 91761, United States
Phone: (601) 213-4426
Email: info@benchchem.com

[Contact our Ph.D. Support Team for a compatibility check](#)