

Technical Support Center: Troubleshooting Off-Target Effects of EGFRi-58

Author: BenchChem Technical Support Team. **Date:** April 2026

Compound of Interest

Compound Name: *Egfr-IN-58*

Cat. No.: *B15143611*

[Get Quote](#)

This technical support guide is designed for researchers, scientists, and drug development professionals using EGFRi-58. Below you will find troubleshooting advice and frequently asked questions to address common challenges and ensure the generation of consistent and reliable data.

Frequently Asked Questions (FAQs)

Q1: We are observing a response to EGFRi-58 in a cell line with low or no EGFR expression. What is the likely cause?

A1: This is a strong indication of an off-target effect. While EGFRi-58 is a potent inhibitor of the Epidermal Growth Factor Receptor (EGFR) tyrosine kinase, it can inhibit other kinases at higher concentrations. This is often due to the conserved nature of the ATP-binding pocket across the human kinome.[1] We recommend consulting the in vitro kinase selectivity profile for EGFRi-58 (see Table 1) to identify potential off-target kinases that may be active in your cell line. Furthermore, conducting a dose-response experiment is crucial to determine if the observed effect occurs at concentrations significantly higher than the IC50 for EGFR.[2]

Q2: Our cells are showing unexpected phenotypic changes (e.g., altered morphology, unanticipated levels of apoptosis) that are not typically associated with EGFR inhibition. How

can we determine if these are off-target effects?

A2: Unforeseen cellular responses can often be attributed to the inhibition of alternative signaling pathways.[1] To dissect whether these effects are on-target or off-target, consider the following control experiments:

- Use a structurally unrelated EGFR inhibitor: If a different class of EGFR inhibitor does not elicit the same phenotype, it is more likely that the effect of EGFRi-58 is due to off-target activity.[2]
- Rescue Experiment: For on-target effects, you may be able to rescue the phenotype by overexpressing a drug-resistant mutant of EGFR.[1]
- RNAi-mediated knockdown: To confirm the involvement of a suspected off-target kinase, knocking down its expression using RNAi should prevent the phenotype observed with EGFRi-58 treatment.

Q3: At what concentration should we use EGFRi-58 to minimize off-target effects?

A3: It is critical to use the lowest concentration of the inhibitor that produces the desired on-target effect, such as the inhibition of EGFR phosphorylation. A dose-response experiment is essential to determine the half-maximal inhibitory concentration (IC50) for EGFR inhibition in your specific cellular context. Using concentrations significantly above the IC50 for EGFR dramatically increases the probability of engaging off-target kinases.

Q4: We are observing inconsistent results between experiments. What are the potential causes?

A4: Inconsistent results in cell-based assays can arise from several factors:

- Variability in Cell Culture: Differences in cell density, passage number, and overall cell health can alter the cellular response to inhibitors.
- Compound Stability and Solubility: Degradation or precipitation of EGFRi-58 in your culture medium will result in a lower effective concentration. Always prepare fresh dilutions from a validated stock solution for each experiment.

- Experimental Technique: Inaccuracies in pipetting and inconsistencies in cell seeding can introduce significant variability.

Data Presentation

Table 1: Kinase Selectivity Profile of EGFRi-58

The following table summarizes the inhibitory activity of EGFRi-58 against its primary target (EGFR) and a selection of potential off-target kinases. Data were generated using a radiometric kinase assay.

Kinase Target	IC50 (nM)
EGFR (Primary Target)	5
SRC	850
ABL1	1,200
LCK	2,500
VEGFR2	>10,000
PDGFR β	>10,000

IC50 values represent the concentration of EGFRi-58 required to inhibit 50% of the kinase activity in vitro. Data is for illustrative purposes.

Experimental Protocols

Protocol 1: Cellular Phospho-EGFR Assay (Western Blot)

This protocol details the steps to assess the on-target activity of EGFRi-58 by measuring the inhibition of EGF-induced EGFR phosphorylation.

Materials:

- A431 cells (or other EGFR-expressing cell line)

- Complete culture medium
- Serum-free culture medium
- EGFRi-58
- Epidermal Growth Factor (EGF)
- Phosphate-Buffered Saline (PBS)
- RIPA buffer with protease and phosphatase inhibitors
- BCA Protein Assay Kit
- SDS-PAGE gels
- Transfer buffer
- PVDF membrane
- Blocking buffer (e.g., 5% BSA in TBST)
- Primary antibodies (anti-phospho-EGFR, anti-total-EGFR, anti- β -actin)
- HRP-conjugated secondary antibody
- Enhanced chemiluminescence (ECL) substrate

Procedure:

- **Cell Culture and Starvation:** Plate A431 cells and grow to 70-80% confluency. Serum-starve the cells for 12-24 hours to reduce basal EGFR activity.
- **Inhibitor Treatment:** Pre-treat the cells with various concentrations of EGFRi-58 for 1-2 hours.
- **Ligand Stimulation:** Stimulate the cells with EGF (e.g., 100 ng/mL) for 10-15 minutes to induce EGFR phosphorylation.

- Cell Lysis: Wash cells twice with ice-cold PBS and lyse them in RIPA buffer containing protease and phosphatase inhibitors.
- Protein Quantification: Determine the protein concentration of the lysates using a BCA assay.
- Western Blotting:
 - Separate equal amounts of protein lysate by SDS-PAGE and transfer to a PVDF membrane.
 - Block the membrane with blocking buffer for 1 hour at room temperature.
 - Incubate the membrane with anti-phospho-EGFR primary antibody overnight at 4°C.
 - Wash the membrane and incubate with an HRP-conjugated secondary antibody for 1 hour at room temperature.
 - Detect the signal using an ECL substrate.
 - Strip the membrane and re-probe for total EGFR and a loading control (e.g., β -actin) to normalize the data.

Protocol 2: In Vitro Kinase Assay (Radiometric)

This protocol provides a general method for determining the in vitro kinase activity and inhibition by EGFRi-58 against a panel of kinases.

Materials:

- Purified recombinant kinases
- Specific peptide or protein substrates for each kinase
- EGFRi-58 stock solution (e.g., 10 mM in DMSO)
- Kinase reaction buffer
- [γ -³³P]ATP

- ATP solution
- Microplates (96-well or 384-well)
- Phosphocellulose filter plates
- Scintillation counter

Procedure:

- Prepare serial dilutions of EGFRi-58 in DMSO.
- In the wells of a microplate, add the kinase reaction buffer.
- Add the appropriate amount of the specific kinase to each well.
- Add the serially diluted EGFRi-58 or DMSO (vehicle control) to the wells.
- Incubate for 10-15 minutes at room temperature to allow for inhibitor binding.
- Initiate the kinase reaction by adding a mixture of the specific substrate and [γ -³³P]ATP. The ATP concentration should be at the K_m for each kinase for accurate IC₅₀ determination.
- Incubate the reaction for a defined period at the optimal temperature for the kinase.
- Stop the reaction and transfer the reaction mixture to a phosphocellulose filter plate to capture the phosphorylated substrate.
- Wash the filter plate to remove unincorporated [γ -³³P]ATP.
- Measure the radioactivity in each well using a scintillation counter.
- Calculate the percentage of kinase activity inhibition for each concentration of EGFRi-58 compared to the DMSO control and determine the IC₅₀ value.

Visualizations

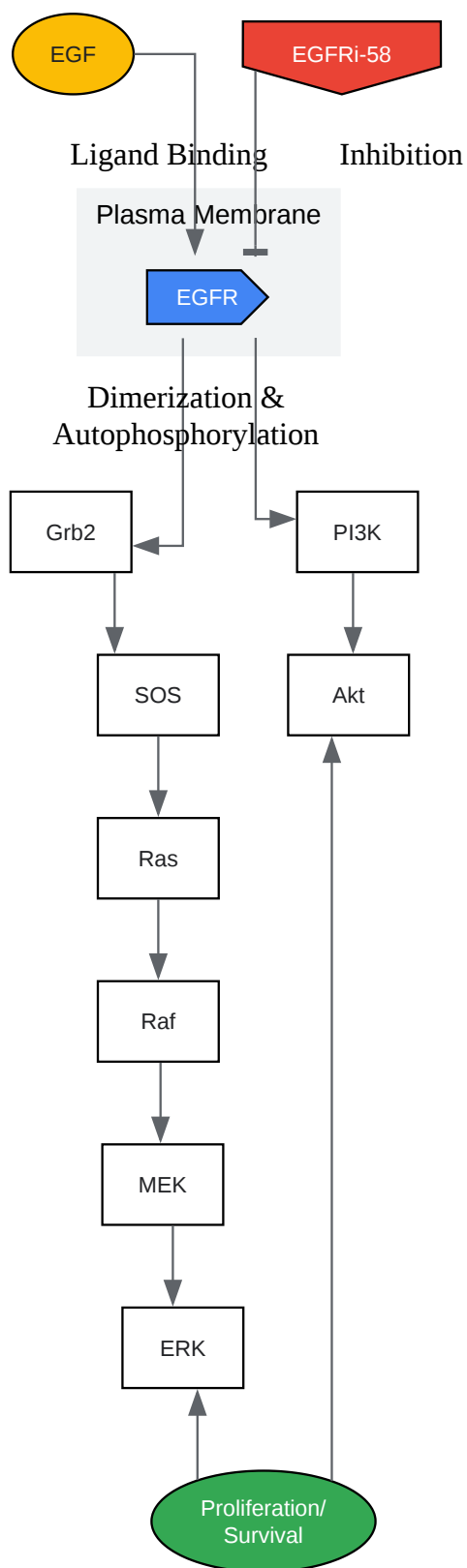

[Click to download full resolution via product page](#)

Caption: Simplified EGFR signaling pathway and the inhibitory action of EGFRi-58.

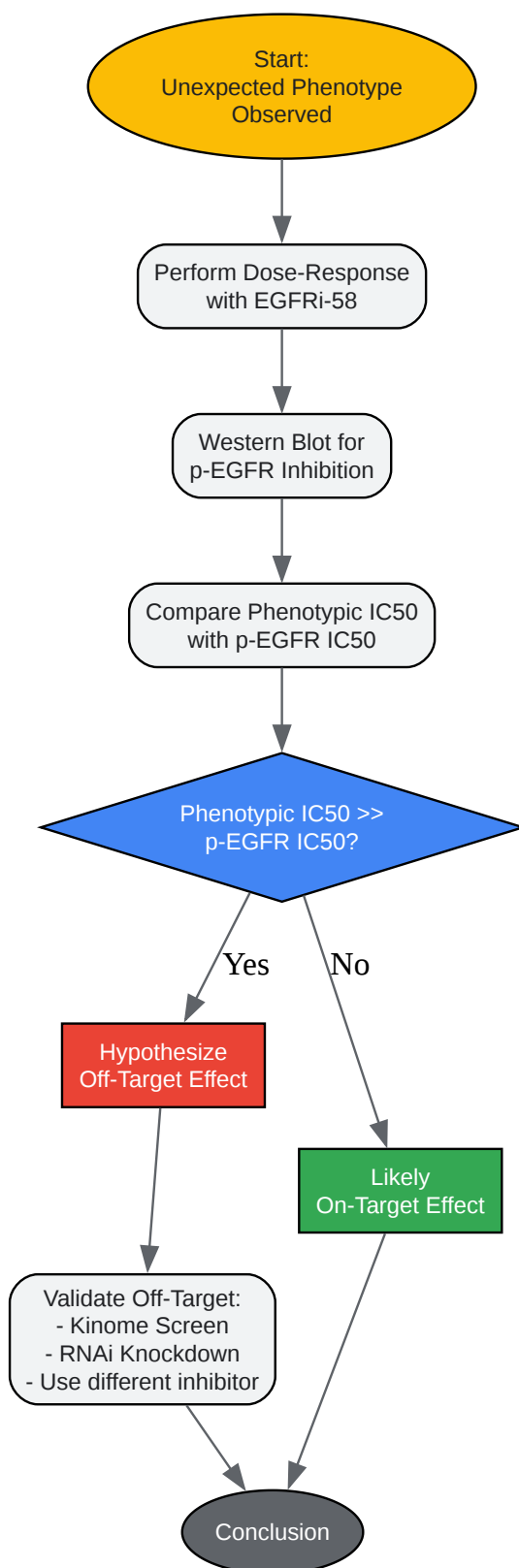

[Click to download full resolution via product page](#)

Caption: Experimental workflow for investigating potential off-target effects.

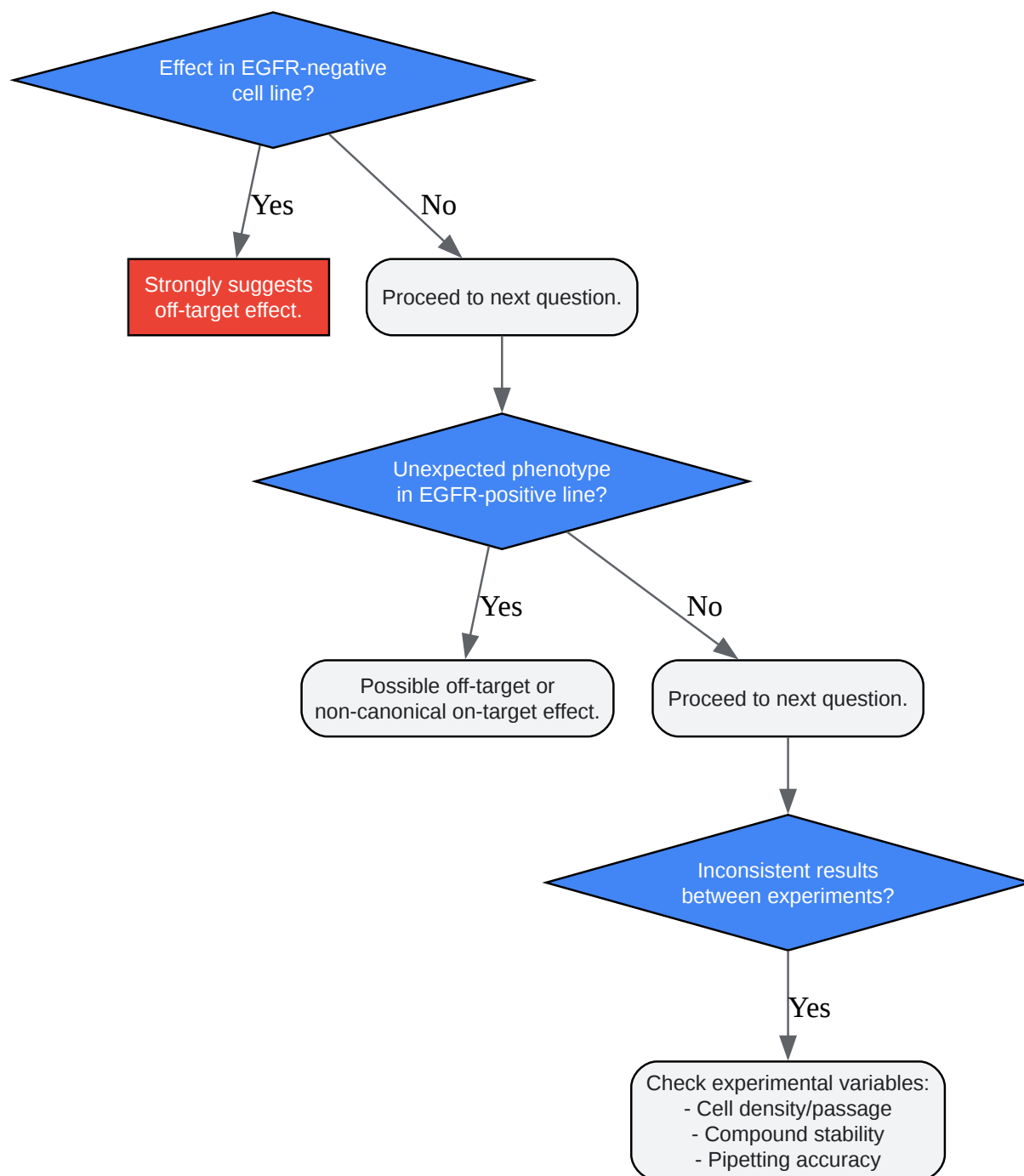

[Click to download full resolution via product page](#)

Caption: Logical flowchart for troubleshooting common issues with EGFRi-58.

Need Custom Synthesis?

BenchChem offers custom synthesis for rare earth carbides and specific isotopic labeling.

Email: info@benchchem.com or [Request Quote Online](#).

References

- [1. benchchem.com \[benchchem.com\]](#)
- [2. benchchem.com \[benchchem.com\]](#)
- To cite this document: BenchChem. [Technical Support Center: Troubleshooting Off-Target Effects of EGFRi-58]. BenchChem, [2026]. [Online PDF]. Available at: [\[https://www.benchchem.com/product/b15143611/docs#technical-support-center-troubleshooting-off-target-effects-of-egfri-58\]](https://www.benchchem.com/product/b15143611/docs#technical-support-center-troubleshooting-off-target-effects-of-egfri-58)

Disclaimer & Data Validity:

The information provided in this document is for Research Use Only (RUO) and is strictly not intended for diagnostic or therapeutic procedures. While BenchChem strives to provide accurate protocols, we make no warranties, express or implied, regarding the fitness of this product for every specific experimental setup.

Technical Support: The protocols provided are for reference purposes. Unsure if this reagent suits your experiment?

Need Industrial/Bulk Grade? [Request Custom Synthesis Quote](#)

BenchChem

Our mission is to be the trusted global source of essential and advanced chemicals, empowering scientists and researchers to drive progress in science and industry.

Contact

Address: 3281 E Guasti Rd
Ontario, CA 91761, United States
Phone: (601) 213-4426
Email: info@benchchem.com

Contact our Ph.D. Support Team for a compatibility check