

Hiv-IN-4: Application Notes and Protocols for HIV Integrase Research

Author: BenchChem Technical Support Team. **Date:** April 2026

Compound of Interest

Compound Name: *Hiv-IN-4*
Cat. No.: *B15143098*

[Get Quote](#)

For Research Use Only. Not for use in diagnostic procedures.

Introduction

Hiv-IN-4, also cataloged as Compound 12, is a potent inhibitor of the human immunodeficiency virus (HIV) that shows promise as a tool compound for research targeting HIV integrase.[1][2][3] As an essential enzyme for viral replication, HIV integrase is a well-established target for antiretroviral therapy. **Hiv-IN-4** belongs to a novel class of inhibitors and can be utilized in studies aimed at understanding the mechanism of HIV integration, identifying new drug binding pockets, and characterizing drug resistance.

This document provides an overview of the available data on **Hiv-IN-4** and generalized protocols for its application in HIV integrase research. It is important to note that publicly available information on **Hiv-IN-4** is limited, and the data presented here is based on findings for compounds referred to as "Compound 12" in scientific literature, which are understood to be identical to or structurally related to **Hiv-IN-4**.

Mechanism of Action

HIV integrase facilitates the insertion of the viral DNA into the host cell's genome in a two-step process: 3'-processing and strand transfer. **Hiv-IN-4** has been identified as an inhibitor of the strand transfer step of this process.[4] By blocking this crucial step, **Hiv-IN-4** effectively prevents the integration of the viral genome, thereby halting the replication cycle of the virus.

Biochemical and Cellular Activity

Quantitative data for **Hiv-IN-4** (Compound 12) from published research is summarized below. It is important to note that different studies might refer to different molecules as "Compound 12". Researchers should carefully consider the original publications when interpreting this data.

Table 1: Antiviral and Inhibitory Activity of **Hiv-IN-4** (Compound 12)

Assay	Description	Value	Reference
HIV-1 Replication	Cell-based assay measuring the concentration required to inhibit 95% of viral replication (CIC95).	0.31 μ M	[4]
Integrase Catalytic Activity	Biochemical assay measuring the 50% inhibitory concentration (IC50) against the catalytic activity of HIV-1 integrase.	387 μ M	[5][6]

Note: The significant difference in potency between the cell-based and biochemical assays may be due to various factors, including cell permeability, off-target effects, or differences in the specific "Compound 12" molecule tested.

Experimental Protocols

The following are generalized protocols based on the types of experiments in which **Hiv-IN-4** or similar compounds have been evaluated. Researchers should optimize these protocols for their

specific experimental conditions.

Protocol 1: HIV-1 Replication Assay (Cell-Based)

This protocol is a general guideline for assessing the antiviral activity of **Hiv-IN-4** in a cell culture system.

1. Cell Culture and Virus Preparation:

- Culture a suitable host cell line (e.g., MT-4 cells) in appropriate media.
- Prepare a stock of HIV-1 with a known titer.

2. Assay Procedure:

- Seed cells in a 96-well plate at a predetermined density.
- Prepare serial dilutions of **Hiv-IN-4** in culture medium.
- Add the diluted compound to the cells.
- Infect the cells with a predetermined multiplicity of infection (MOI) of HIV-1.
- Incubate the plate for a period that allows for multiple rounds of viral replication (e.g., 4-5 days).

3. Measurement of Viral Replication:

- Quantify viral replication using a suitable method, such as:
- p24 antigen ELISA to measure the amount of viral capsid protein in the supernatant.
- A reporter gene assay (e.g., luciferase or β -galactosidase) if using a reporter virus.

4. Data Analysis:

- Calculate the percentage of inhibition of viral replication for each concentration of **Hiv-IN-4** compared to a no-drug control.
- Determine the CIC95 or EC50 value by plotting the percentage of inhibition against the compound concentration and fitting the data to a dose-response curve.

Protocol 2: HIV-1 Integrase Strand Transfer Assay (Biochemical)

This protocol provides a framework for evaluating the direct inhibitory effect of **Hiv-IN-4** on the strand transfer activity of purified HIV-1 integrase.

1. Reagents and Materials:

- Purified recombinant HIV-1 integrase.
- Oligonucleotide substrates mimicking the viral DNA ends (donor DNA) and a target DNA. These are often labeled (e.g., with a fluorescent tag or biotin) for detection.
- Assay buffer containing divalent cations (e.g., Mg²⁺ or Mn²⁺), which are essential for integrase activity.
- **Hiv-IN-4** stock solution in a suitable solvent (e.g., DMSO).

2. Assay Procedure:

- Prepare serial dilutions of **Hiv-IN-4** in the assay buffer.
- In a reaction vessel (e.g., a microplate well), combine the purified HIV-1 integrase, the donor DNA substrate, and the diluted **Hiv-IN-4** or vehicle control.
- Pre-incubate the mixture to allow the inhibitor to bind to the enzyme.
- Initiate the reaction by adding the target DNA substrate.
- Incubate the reaction at 37°C for a defined period (e.g., 60 minutes).

3. Detection and Analysis:

- Stop the reaction (e.g., by adding a chelating agent like EDTA).
- Separate the reaction products (unreacted substrates and strand transfer products) using gel electrophoresis or a capture-based method (e.g., ELISA).
- Quantify the amount of strand transfer product.
- Calculate the percentage of inhibition for each **Hiv-IN-4** concentration relative to the vehicle control.
- Determine the IC₅₀ value by plotting the percentage of inhibition against the compound concentration and fitting the data to a dose-response curve.

Visualizations

HIV-1 Integrase Catalytic Steps and Inhibition

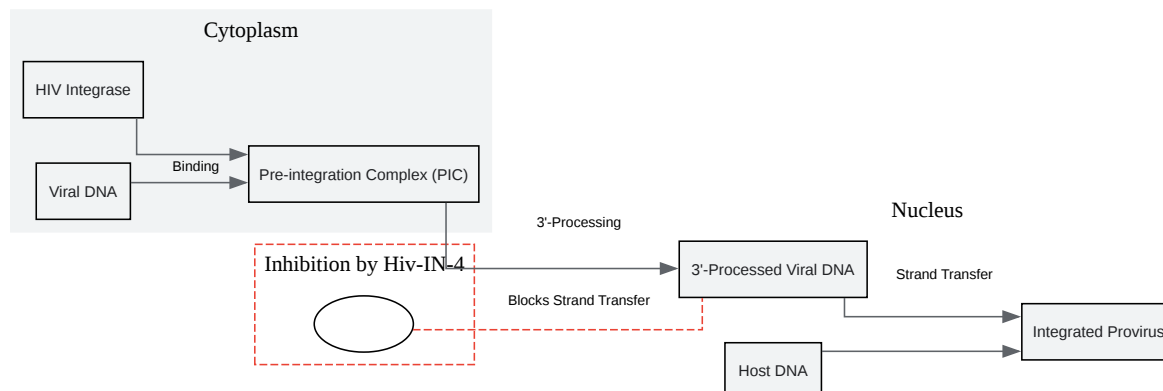

[Click to download full resolution via product page](#)

Caption: Mechanism of HIV-1 integrase and the inhibitory action of **Hiv-IN-4**.

General Workflow for Screening HIV Integrase Inhibitors

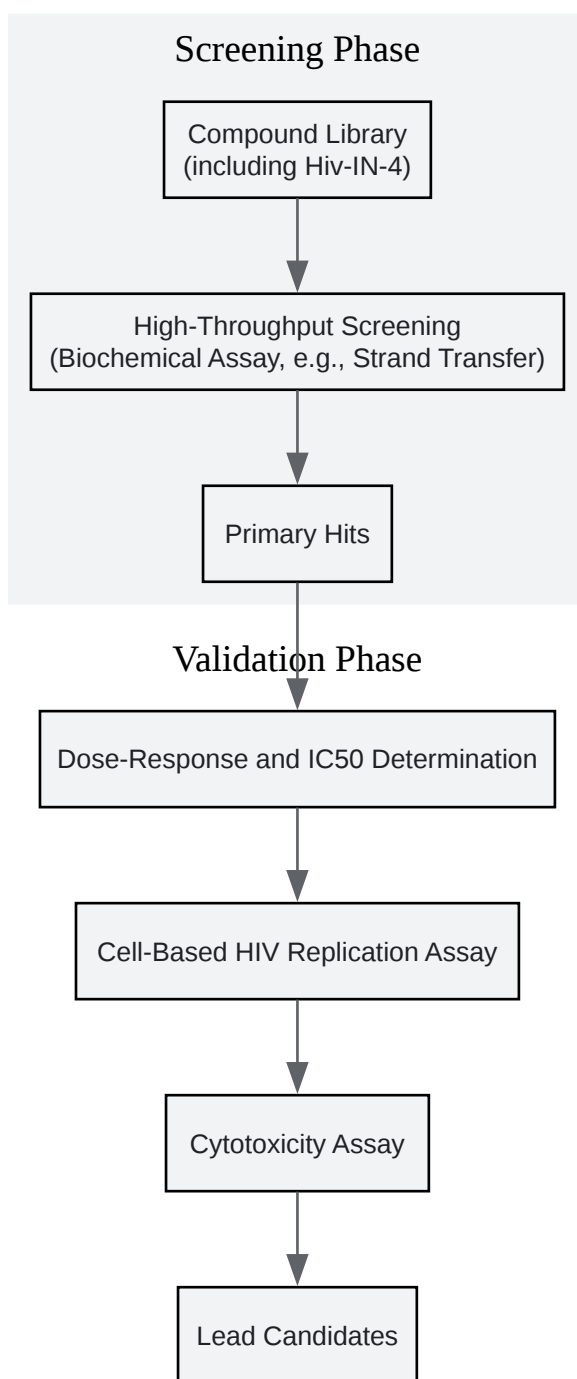

[Click to download full resolution via product page](#)

Caption: A generalized workflow for the identification and validation of HIV integrase inhibitors.

Need Custom Synthesis?

BenchChem offers custom synthesis for rare earth carbides and specific isotopic labeling.

Email: info@benchchem.com or [Request Quote Online](#).

References

- [1. medchemexpress.com \[medchemexpress.com\]](https://www.medchemexpress.com)
- [2. medchemexpress.com \[medchemexpress.com\]](https://www.medchemexpress.com)
- [3. HIV-产品分类-Felix \[felixbio.cn\]](https://www.felixbio.cn)
- [4. 8-Hydroxy-3,4-dihydropyrrolo\[1,2-a\]pyrazine-1\(2H\)-one HIV-1 integrase inhibitors - PubMed \[pubmed.ncbi.nlm.nih.gov\]](https://pubmed.ncbi.nlm.nih.gov)
- [5. Identification and Optimization of a Novel HIV-1 Integrase Inhibitor - PMC \[pmc.ncbi.nlm.nih.gov\]](https://pubmed.ncbi.nlm.nih.gov)
- [6. researchgate.net \[researchgate.net\]](https://www.researchgate.net)
- To cite this document: BenchChem. [Hiv-IN-4: Application Notes and Protocols for HIV Integrase Research]. BenchChem, [2026]. [Online PDF]. Available at: [\[https://www.benchchem.com/product/b15143098/docs#hiv-in-4-application-notes-and-protocols-for-hiv-integrase-research\]](https://www.benchchem.com/product/b15143098/docs#hiv-in-4-application-notes-and-protocols-for-hiv-integrase-research)

Disclaimer & Data Validity:

The information provided in this document is for Research Use Only (RUO) and is strictly not intended for diagnostic or therapeutic procedures. While BenchChem strives to provide accurate protocols, we make no warranties, express or implied, regarding the fitness of this product for every specific experimental setup.

Technical Support: The protocols provided are for reference purposes. Unsure if this reagent suits your experiment?

Need Industrial/Bulk Grade? [Request Custom Synthesis Quote](#)

BenchChem

Our mission is to be the trusted global source of essential and advanced chemicals, empowering scientists and researchers to drive progress in science and industry.

Contact

Address: 3281 E Guasti Rd

Ontario, CA 91761, United States

Phone: (601) 213-4426

Email: info@benchchem.com

[Contact our Ph.D. Support Team for a compatibility check](#)