

Application Notes and Protocols for DS17701585 in High-Throughput Screening Assays

Author: BenchChem Technical Support Team. **Date:** May 2026

Compound of Interest

Compound Name: DS17701585

Cat. No.: B15142737

[Get Quote](#)

For Research Use Only. Not for use in diagnostic procedures.

Introduction

Sentrin-specific protease 1 (SEN1) is a cysteine protease that plays a crucial role in the regulation of protein SUMOylation, a post-translational modification essential for numerous cellular processes, including cell cycle control, DNA repair, and apoptosis.[1] Dysregulation of the SUMOylation/deSUMOylation balance is implicated in the pathogenesis of various diseases, particularly cancer, where SEN1 is often overexpressed.[1][2] This makes SEN1 a compelling therapeutic target for the development of novel anti-cancer agents.[2][3]

DS17701585 is a potent and selective small molecule inhibitor of SEN1, designed for use in high-throughput screening (HTS) assays to identify and characterize modulators of the SUMOylation pathway. These application notes provide detailed protocols for the use of **DS17701585** in biochemical and cell-based assays.

Mechanism of Action

DS17701585 exerts its inhibitory effect by targeting the catalytic activity of the SEN1 enzyme. SEN1 is responsible for two key processes in the SUMOylation pathway: the maturation of SUMO (Small Ubiquitin-like Modifier) proteins and the deconjugation of SUMO from target

proteins.[1][3] By inhibiting SENP1, **DS17701585** leads to an accumulation of SUMOylated proteins, which can trigger downstream cellular events such as cell cycle arrest and apoptosis in cancer cells. The simplified signaling pathway is depicted below.

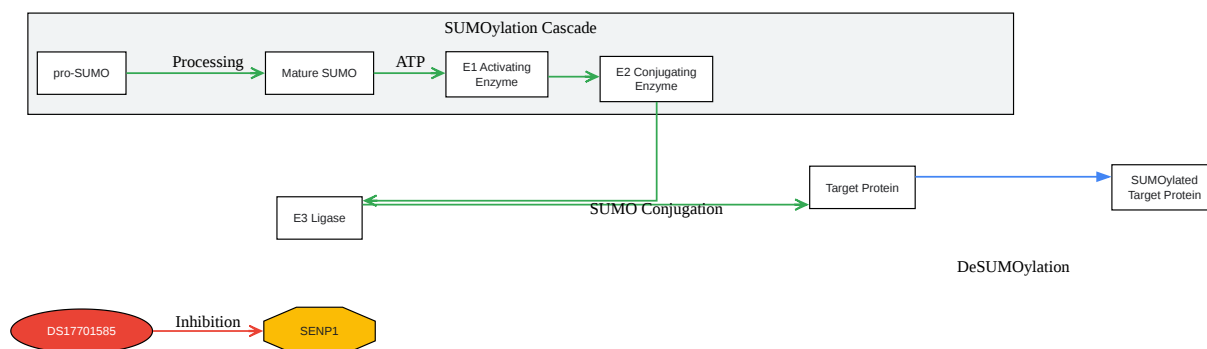

[Click to download full resolution via product page](#)

Figure 1: SENP1 Signaling Pathway Inhibition by **DS17701585**.

Quantitative Data Summary

The inhibitory activity and selectivity of **DS17701585** were evaluated using a panel of biochemical and cell-based assays. All quantitative data are summarized in the tables below for easy comparison.

Table 1: Biochemical Assay Data for **DS17701585**

Target	Assay Type	IC50 (µM)
SEN1	Enzymatic (Fluorogenic)	0.05
SEN2	Enzymatic (Fluorogenic)	1.2
SEN3	Enzymatic (Fluorogenic)	5.8
SEN5	Enzymatic (Fluorogenic)	> 50
UCH-L1	Enzymatic (Fluorogenic)	> 100
Caspase-3	Enzymatic (Fluorogenic)	> 100

Table 2: Cell-Based Assay Data for **DS17701585**

Cell Line	Assay Type	EC50 (µM)
PC-3	Cell Viability (72 hr)	0.5
HeLa	Cell Viability (72 hr)	1.1
MCF-7	Cell Viability (72 hr)	2.5
HEK293	Cell Viability (72 hr)	> 20

High-Throughput Screening Protocols

The following protocols are designed for high-throughput screening to identify and characterize SENP1 inhibitors.

SEN1 Inhibitor HTS Biochemical Assay Protocol

This protocol describes a fluorescence-based enzymatic assay to measure the inhibitory activity of compounds against SEN1.

Materials:

- Assay Buffer: 20 mM HEPES (pH 7.5), 150 mM NaCl, 5 mM DTT, 0.01% Tween-20
- Recombinant Human SEN1 Enzyme

- Fluorogenic SENP1 Substrate (e.g., SUMO1-AMC)
- **DS17701585** (or test compounds)
- 384-well black, flat-bottom assay plates
- Fluorescence plate reader

Workflow Diagram:

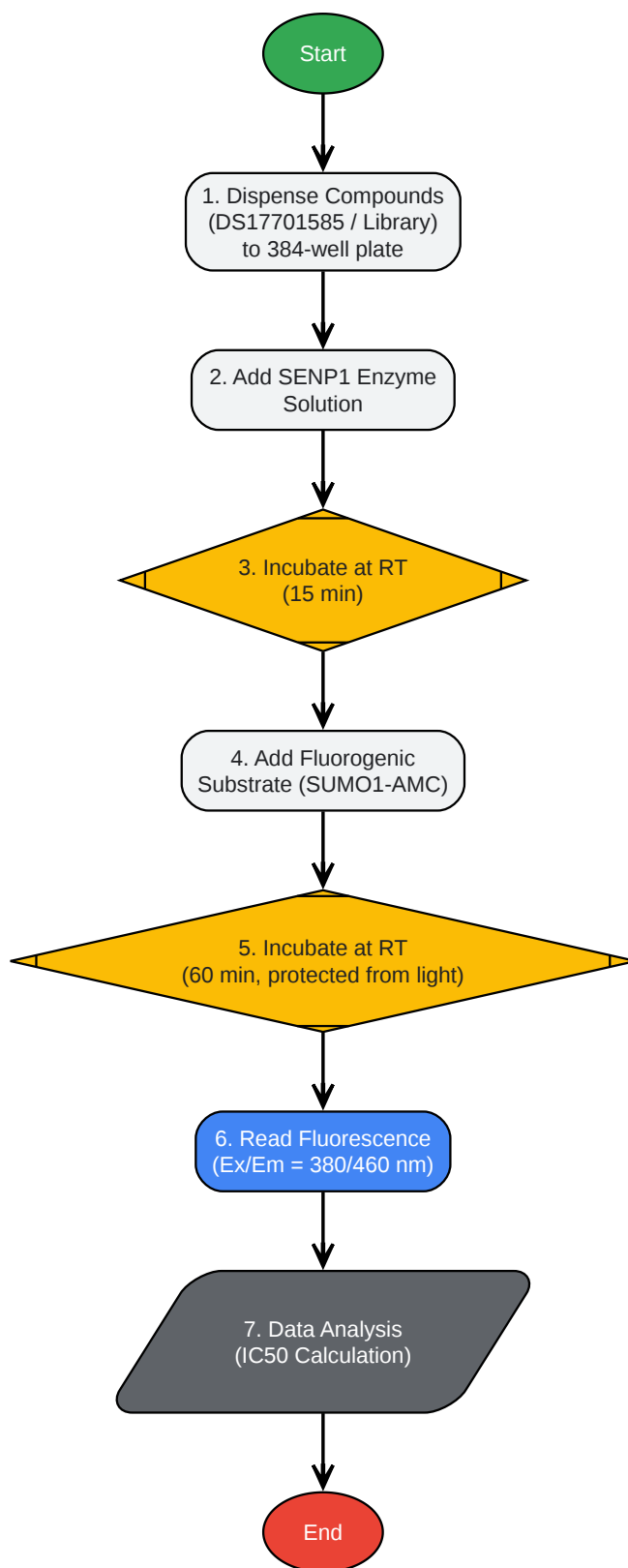

[Click to download full resolution via product page](#)

Need Custom Synthesis?

BenchChem offers custom synthesis for rare earth carbides and specific isotopic labeling.

Email: info@benchchem.com or [Request Quote Online](#).

References

- [1. mdpi.com \[mdpi.com\]](#)
- [2. researchgate.net \[researchgate.net\]](#)
- [3. mdpi.com \[mdpi.com\]](#)
- To cite this document: BenchChem. [Application Notes and Protocols for DS17701585 in High-Throughput Screening Assays]. BenchChem, [2026]. [Online PDF]. Available at: [\[https://www.benchchem.com/product/b15142737/docs#application-notes-and-protocols-for-ds17701585-in-high-throughput-screening-assays\]](https://www.benchchem.com/product/b15142737/docs#application-notes-and-protocols-for-ds17701585-in-high-throughput-screening-assays)

Disclaimer & Data Validity:

The information provided in this document is for Research Use Only (RUO) and is strictly not intended for diagnostic or therapeutic procedures. While BenchChem strives to provide accurate protocols, we make no warranties, express or implied, regarding the fitness of this product for every specific experimental setup.

Technical Support: The protocols provided are for reference purposes. Unsure if this reagent suits your experiment?

Need Industrial/Bulk Grade? [Request Custom Synthesis Quote](#)

BenchChem

Our mission is to be the trusted global source of essential and advanced chemicals, empowering scientists and researchers to drive progress in science and industry.

Contact

Address: 3281 E Guasti Rd

Ontario, CA 91761, United States

Phone: (601) 213-4426

Email: info@benchchem.com

Contact our Ph.D. Support Team for a compatibility check