

Navigating the Preclinical Landscape of N1-Substituted Pseudouridines for Enhanced mRNA Therapeutics

Author: BenchChem Technical Support Team. **Date:** December 2025

Compound of Interest

Compound Name: *N1-(1,1,1-Trifluoroethyl)pseudoUridine*

Cat. No.: *B15140137*

[Get Quote](#)

A Technical Guide for Researchers and Drug Development Professionals

Disclaimer: This whitepaper addresses the preclinical evaluation of N1-substituted pseudouridines in mRNA therapeutics. While the user's interest was in **N1-(1,1,1-Trifluoroethyl)pseudoUridine**, a comprehensive search of publicly available scientific literature and preclinical study databases did not yield specific data for this particular modification. Therefore, this guide focuses on the broader class of N1-substituted pseudouridines, with a primary emphasis on the extensively studied and clinically validated N1-methylpseudouridine (m1 Ψ) as a representative molecule. The principles and methodologies described herein are directly applicable to the preclinical assessment of novel N1-substituted pseudouridines like **N1-(1,1,1-Trifluoroethyl)pseudoUridine**.

Introduction

The advent of messenger RNA (mRNA) therapeutics and vaccines has revolutionized modern medicine. A key innovation underpinning the success of this platform is the strategic use of modified nucleosides to enhance mRNA stability, increase protein translation, and mitigate the innate immune responses that can hamper efficacy and cause adverse effects.^{[1][2][3]} Unmodified synthetic mRNA can be recognized by pattern recognition receptors (PRRs) such as Toll-like receptors (TLR7/8), RIG-I, and MDA5, triggering inflammatory pathways that can lead to mRNA degradation and translational shutdown.^{[1][2]}

The incorporation of pseudouridine (Ψ), a naturally occurring isomer of uridine, was a foundational step in overcoming these hurdles.[1][2] Further optimization led to the development of N1-substituted pseudouridine analogs, most notably N1-methylpseudouridine (m1 Ψ), which has become a cornerstone of highly effective mRNA vaccines and therapeutics, including the Pfizer-BioNTech and Moderna COVID-19 vaccines.[1][2][4][5] These modifications have been shown to significantly improve the therapeutic index of mRNA by enhancing protein production while further reducing immunogenicity.[2][3][6] This technical guide provides an in-depth overview of the preclinical evaluation of N1-substituted pseudouridines, focusing on the core data, experimental protocols, and underlying biological pathways.

Quantitative Data on the Impact of N1-Substituted Pseudouridines

The preclinical evaluation of novel mRNA modifications hinges on quantifiable improvements in performance compared to standard uridine or other modifications. The following tables summarize key quantitative data for N1-methylpseudouridine (m1 Ψ) from various studies.

Table 1: In Vitro Protein Expression

Cell Line	Reporter Gene	Modification	Fold Increase in Protein Expression (vs. Uridine)	Fold Increase in Protein Expression (vs. Pseudouridine)	Reference
HEK293	Firefly Luciferase	m1 Ψ	~10-20	~2-5	[6]
HeLa	Firefly Luciferase	m1 Ψ	~15	~3	[6]
A549	Firefly Luciferase	m1 Ψ	~12	~4	[6]

Table 2: In Vivo Protein Expression in Mice

Reporter Gene	Administration Route	Modification	Fold Increase in Protein Expression (vs. Uridine)	Fold Increase in Protein Expression (vs. Pseudouridine)	Reference
Firefly Luciferase	Intramuscular	m1Ψ	>100	~10	[6]
Erythropoietin	Intravenous	m1Ψ	~50-100	~5-10	[6]

Table 3: Reduction of Innate Immune Stimulation

Cell Line	Cytokine Measured	Modification	Fold Decrease in Cytokine Secretion (vs. Uridine)	Reference
Human PBMCs	TNF-α	m1Ψ	>100	[6]
Human PBMCs	IFN-α	m1Ψ	>100	[6]

Key Experimental Protocols

The preclinical assessment of N1-substituted pseudouridine-modified mRNA involves a series of standardized in vitro and in vivo experiments.

In Vitro Transcription (IVT) for Modified mRNA Synthesis

This is the foundational step for producing the mRNA to be tested.

- **Template Generation:** A linear DNA template containing the gene of interest (e.g., a reporter gene like Firefly Luciferase or a therapeutic protein) flanked by T7 or SP6 RNA polymerase promoter and a poly(A) tail is generated by PCR or plasmid linearization.
- **IVT Reaction:** The reaction mixture includes:

- The DNA template
- RNA polymerase (T7 or SP6)
- Ribonuclease inhibitors
- A mixture of the four ribonucleotide triphosphates (NTPs): ATP, GTP, CTP, and the modified UTP (e.g., N1-methylpseudouridine-5'-triphosphate). The standard UTP is completely replaced by the modified analog.
- A cap analog (e.g., CleanCap™) to ensure proper capping of the 5' end of the mRNA, which is crucial for translation initiation and stability.[7]
- Purification: The resulting mRNA is purified to remove enzymes, unincorporated NTPs, and the DNA template. This is often achieved using DNase treatment followed by a purification method such as lithium chloride precipitation or silica-based columns.
- Quality Control: The integrity and concentration of the synthesized mRNA are verified using methods like gel electrophoresis and spectrophotometry.

In Vitro Transfection and Reporter Gene Assays

These experiments assess the translational efficiency of the modified mRNA in a controlled cellular environment.

- Cell Culture: A relevant cell line (e.g., HEK293, HeLa, or immune cells like THP-1 monocytes) is cultured to an appropriate confluency.
- Transfection: The purified mRNA is complexed with a transfection reagent (e.g., a lipid nanoparticle formulation or a commercially available transfection reagent) and added to the cells.
- Reporter Gene Analysis: After a set incubation period (e.g., 24-48 hours), the cells are lysed, and the expression of the reporter protein is quantified. For Firefly Luciferase, a luminometer is used to measure the light output upon addition of a luciferin substrate.
- Toxicity Assays: Cell viability can be assessed in parallel using assays like the MTT assay to ensure that the observed protein expression is not confounded by differential cytotoxicity of

the modified mRNAs.[7]

In Vivo Administration and Biodistribution Studies in Animal Models

These studies evaluate the efficacy and safety of the modified mRNA in a living organism, typically mice.

- **Formulation:** The mRNA is formulated, often in lipid nanoparticles (LNPs), to protect it from degradation and facilitate cellular uptake in vivo.
- **Administration:** The formulated mRNA is administered to animals via a relevant route, such as intramuscular (for vaccines) or intravenous (for systemic protein delivery).
- **Quantification of Protein Expression:** At various time points post-administration, tissues or blood are collected. If a reporter gene like luciferase is used, protein expression can be monitored non-invasively using in vivo imaging systems (IVIS). For secreted proteins like erythropoietin, blood samples are analyzed by ELISA.
- **Immunogenicity Assessment:** Blood samples can be collected to measure cytokine levels (e.g., TNF- α , IFN- α) by ELISA or multiplex assays to assess the innate immune response to the modified mRNA.

Visualizing Key Pathways and Workflows

The following diagrams illustrate the critical signaling pathways influenced by mRNA modifications, the general workflow for preclinical evaluation, and the logical framework for the benefits of N1-substitution.

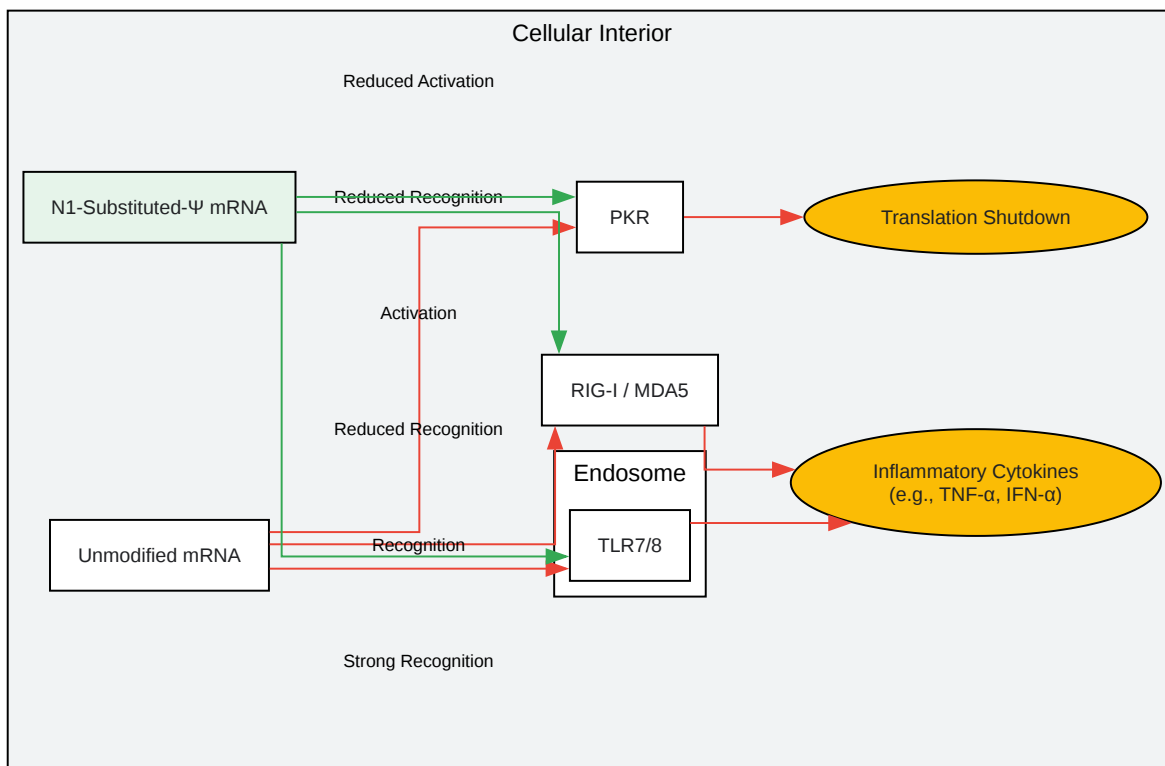

[Click to download full resolution via product page](#)

Caption: Innate immune sensing of unmodified vs. N1-substituted pseudouridine mRNA.

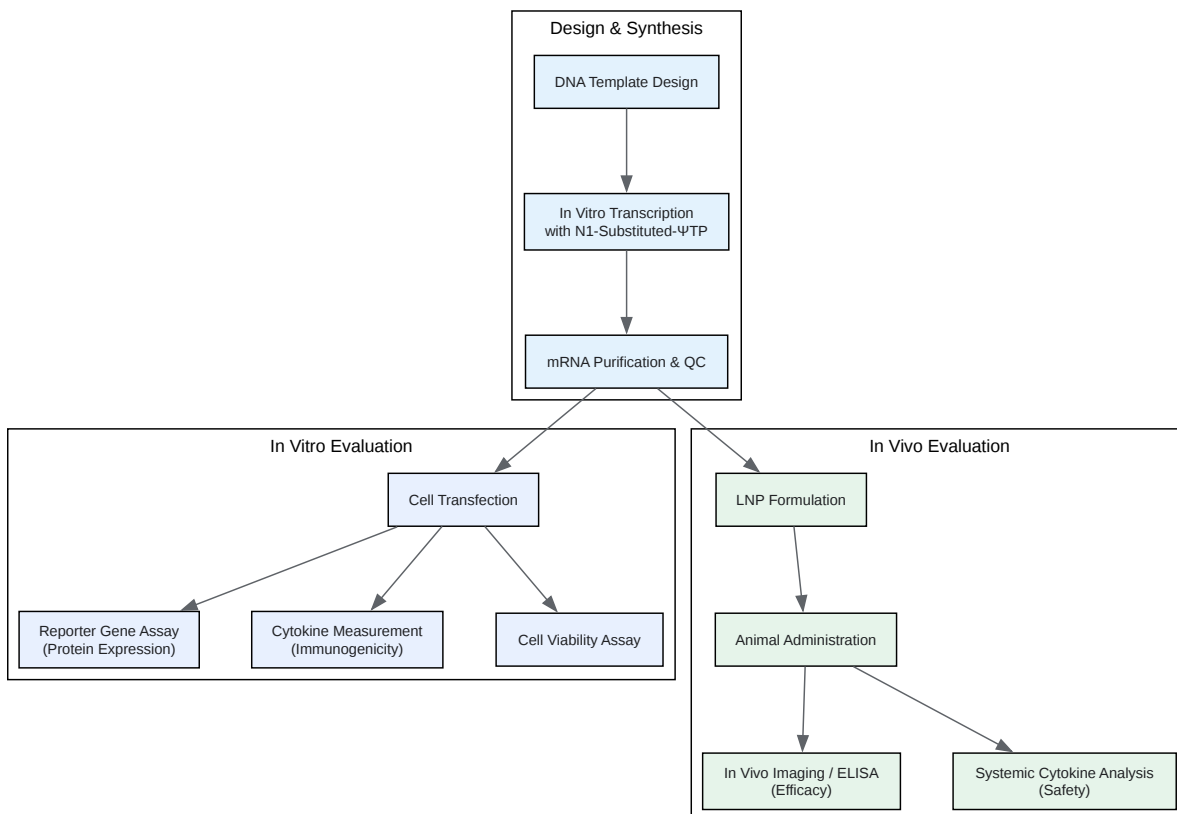

[Click to download full resolution via product page](#)

Caption: General workflow for the preclinical evaluation of modified mRNA.

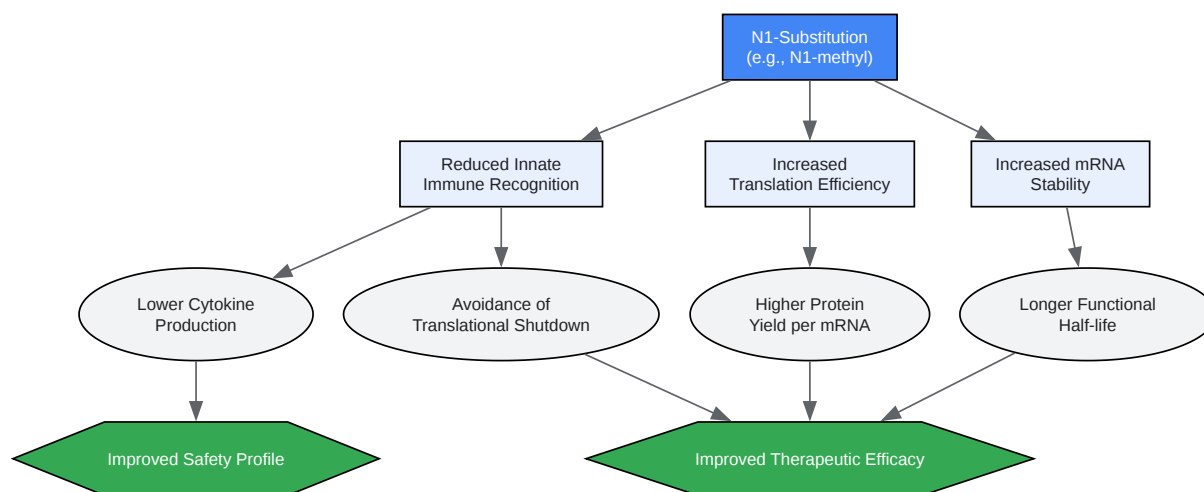

[Click to download full resolution via product page](#)

Caption: The logical relationship between N1-substitution and improved mRNA therapeutic properties.

Conclusion

The incorporation of N1-substituted pseudouridines, particularly N1-methylpseudouridine, has been a pivotal advancement in the field of mRNA therapeutics.[3][8] Preclinical studies consistently demonstrate that this modification significantly enhances protein expression while concurrently dampening the innate immune response, leading to a superior efficacy and safety profile.[2][6] The experimental protocols and evaluation frameworks outlined in this guide provide a robust template for the preclinical assessment of new N1-substituted analogs like **N1-(1,1,1-Trifluoroethyl)pseudoUridine**. As the field continues to evolve, a systematic and quantitative approach to evaluating novel nucleoside modifications will be essential for unlocking the full therapeutic potential of mRNA.

Need Custom Synthesis?

BenchChem offers custom synthesis for rare earth carbides and specific isotopic labeling.

Email: info@benchchem.com or [Request Quote Online](#).

References

- 1. bocsci.com [bocsci.com]
- 2. Modified Nucleotides for mRNA Therapeutics: Pseudouridine, m1Ψ, and Beyond - Areterna LLC [areterna.com]
- 3. backend.orbit.dtu.dk [backend.orbit.dtu.dk]
- 4. preprints.org [preprints.org]
- 5. The Critical Contribution of Pseudouridine to mRNA COVID-19 Vaccines - PubMed [pubmed.ncbi.nlm.nih.gov]
- 6. N1-methyl-pseudouridine is incorporated with higher fidelity than pseudouridine in synthetic RNAs - PMC [pmc.ncbi.nlm.nih.gov]
- 7. trilinkbiotech.com [trilinkbiotech.com]
- 8. Pseudouridine and N 1-methylpseudouridine as potent nucleotide analogues for RNA therapy and vaccine development - PubMed [pubmed.ncbi.nlm.nih.gov]
- To cite this document: BenchChem. [Navigating the Preclinical Landscape of N1-Substituted Pseudouridines for Enhanced mRNA Therapeutics]. BenchChem, [2025]. [Online PDF]. Available at: [<https://www.benchchem.com/product/b15140137#early-preclinical-studies-of-n1-1-1-1-trifluoroethyl-pseudouridine-in-therapeutics>]

Disclaimer & Data Validity:

The information provided in this document is for Research Use Only (RUO) and is strictly not intended for diagnostic or therapeutic procedures. While BenchChem strives to provide accurate protocols, we make no warranties, express or implied, regarding the fitness of this product for every specific experimental setup.

Technical Support: The protocols provided are for reference purposes. Unsure if this reagent suits your experiment? [[Contact our Ph.D. Support Team for a compatibility check](#)]

Need Industrial/Bulk Grade? [Request Custom Synthesis Quote](#)

BenchChem

Our mission is to be the trusted global source of essential and advanced chemicals, empowering scientists and researchers to drive progress in science and industry.

Contact

Address: 3281 E Guasti Rd
Ontario, CA 91761, United States
Phone: (601) 213-4426
Email: info@benchchem.com