

Biomarker Validation for Tanuxiciclib Trihydrochloride Sensitivity: A Comparative Guide

Author: BenchChem Technical Support Team. **Date:** April 2026

Compound of Interest

Compound Name: *Tanuxiciclib trihydrochloride*

Cat. No.: *B15140729*

[Get Quote](#)

For Researchers, Scientists, and Drug Development Professionals

This guide provides a comparative framework for validating biomarkers to predict sensitivity to **Tanuxiciclib trihydrochloride**, a cyclin-dependent kinase (CDK) inhibitor. Due to the limited publicly available data specific to Tanuxiciclib, this document draws upon established principles and data from other CDK inhibitors, particularly selective CDK4/6 inhibitors such as Palbociclib, Ribociclib, and Abemaciclib, to propose a comprehensive validation strategy.

Introduction to Tanuxiciclib and the Role of CDKs in Cancer

Tanuxiciclib trihydrochloride is a small molecule inhibitor of cyclin-dependent kinases (CDKs), key regulators of the cell cycle.^[1] Dysregulation of CDK activity is a hallmark of many cancers, leading to uncontrolled cell proliferation. By targeting CDKs, Tanuxiciclib aims to halt the progression of the cell cycle and induce cancer cell death. The precise inhibitory profile of Tanuxiciclib against various CDKs is crucial for understanding its mechanism of action and for identifying relevant predictive biomarkers. While specific IC50 values for Tanuxiciclib are not

readily available in the public domain, the validation framework presented here is applicable to pan-CDK inhibitors and can be tailored once specific target information becomes known.

Key Biomarker Candidates for CDK Inhibitor Sensitivity

The efficacy of CDK inhibitors is intrinsically linked to the status of the cell cycle regulatory machinery. The retinoblastoma (Rb) protein is a critical tumor suppressor that, when active, prevents entry into the S phase of the cell cycle. CDK4 and CDK6, in complex with Cyclin D, phosphorylate and inactivate Rb, thus promoting cell cycle progression. Therefore, the integrity of the Rb pathway is a primary determinant of sensitivity to CDK4/6 inhibitors.

Table 1: Potential Biomarkers for Sensitivity and Resistance to CDK Inhibitors

| Biomarker Category | Biomarker | Expected Association with Sensitivity | Expected Association with Resistance | Rationale |
|--|--|---------------------------------------|---|--|
| Cell Cycle Regulation | Retinoblastoma (Rb) Protein Expression | Present (functional) | Absent or non-functional | CDK4/6 inhibitors require functional Rb to exert their anti-proliferative effects. Loss of Rb leads to uncontrolled cell cycle progression independent of CDK4/6 activity. |
| Cyclin D1 (CCND1) Amplification/Overexpression | Potential Sensitivity | Potential Resistance | While a direct therapeutic target, high levels of Cyclin D1 may require higher drug concentrations for inhibition and could contribute to resistance. | |
| Cyclin E1 (CCNE1) Amplification/Overexpression | No direct association | Resistance | Cyclin E1/CDK2 acts downstream of CDK4/6 and can independently phosphorylate Rb, bypassing CDK4/6 inhibition. | |

| | | | |
|---|--|--------------------------|--|
| p16 (CDKN2A) Deletion/Inactivation | Potential Sensitivity | No direct association | p16 is a natural inhibitor of CDK4/6. Its loss leads to hyperactivation of the CDK4/6-Rb pathway, potentially increasing dependence on this pathway and sensitivity to its inhibition. |
| Signaling Pathways | Fibroblast Growth Factor Receptor (FGFR) Pathway Alterations | No direct association | Resistance Activation of FGFR signaling can promote cell cycle progression through alternative pathways, reducing reliance on the CDK4/6 axis. |
| PI3K/AKT/mTOR Pathway Alterations | No direct association | Resistance | Constitutive activation of this pathway can drive cell proliferation independently of CDK4/6 signaling. |

Comparative Analysis with Alternative CDK Inhibitors

Several CDK4/6 inhibitors are currently approved and serve as important comparators for Tanuxiciclib.

Table 2: Comparison of Tanuxiciclib with Approved CDK4/6 Inhibitors

| Feature | Tanuxiciclib trihydrochloride | Palbociclib (Ibrance®) | Ribociclib (Kisqali®) | Abemaciclib (Verzenio®) |
|-----------------------|--|---|--|---|
| Target | Cyclin-Dependent Kinase (CDK) inhibitor (specific CDKs not detailed) | CDK4 and CDK6 | CDK4 and CDK6 | CDK4 and CDK6 |
| Reported IC50 | Not publicly available | CDK4: 11 nM, CDK6: 16 nM | CDK4/cyclin D1: 10 nM, CDK6/cyclin D3: 39 nM[2] | CDK4/cyclin D1: 2 nM, CDK6/cyclin D3: 10 nM |
| Key Biomarkers | Hypothesized to be similar to CDK4/6 inhibitors (Rb, Cyclins) | Rb proficiency, Hormone Receptor (HR) status in breast cancer | Rb proficiency, HR status in breast cancer | Rb proficiency, HR status in breast cancer |
| Common Adverse Events | Not publicly available | Neutropenia, leukopenia, fatigue, nausea | Neutropenia, hepatobiliary toxicity, QT interval prolongation, nausea, fatigue | Diarrhea, neutropenia, fatigue, nausea |

Experimental Protocols for Biomarker Validation

A multi-faceted approach is essential for the robust validation of predictive biomarkers. This involves a combination of in vitro, in vivo, and clinical sample analyses.

Immunohistochemistry (IHC) for Retinoblastoma (Rb) Protein Expression

Objective: To determine the presence or absence of functional Rb protein in tumor tissue.

Methodology:

- Tissue Preparation: Formalin-fixed, paraffin-embedded (FFPE) tumor sections are deparaffinized and rehydrated.[3][4][5]
- Antigen Retrieval: Heat-induced epitope retrieval is performed using a citrate buffer (pH 6.0) or Tris-EDTA buffer (pH 9.0) to unmask the Rb protein antigen.[6][7]
- Blocking: Endogenous peroxidase activity is quenched, and non-specific antibody binding is blocked using a serum-free protein block.
- Primary Antibody Incubation: Sections are incubated with a validated monoclonal antibody specific for the Rb protein.[5]
- Detection: A secondary antibody conjugated to a detection enzyme (e.g., horseradish peroxidase) is applied, followed by a chromogenic substrate to visualize the Rb protein.
- Scoring: A pathologist scores the percentage of tumor cells with positive nuclear staining and the intensity of the staining. A tumor is typically considered Rb-positive if a significant proportion of cells show nuclear staining.

Fluorescence In Situ Hybridization (FISH) for CCND1 Gene Amplification

Objective: To detect amplification of the CCND1 gene, which encodes Cyclin D1.

Methodology:

- Probe Design: A locus-specific identifier (LSI) probe for the CCND1 gene on chromosome 11q13 and a chromosome enumeration probe (CEP) for the centromere of chromosome 11 are used.[8][9][10][11]
- Hybridization: The fluorescently labeled probes are hybridized to FFPE tumor sections.
- Signal Enumeration: The number of signals for the CCND1 gene and the centromere of chromosome 11 are counted in a defined number of tumor cell nuclei.
- Interpretation: The ratio of the CCND1 signal to the CEP 11 signal is calculated. A ratio above a predefined threshold (e.g., >2.0) is considered indicative of gene amplification.[9][12]

Next-Generation Sequencing (NGS) for Comprehensive Genomic Profiling

Objective: To identify a broad range of genomic alterations, including mutations, copy number variations, and gene fusions, that may confer sensitivity or resistance.[13][14][15][16]

Methodology:

- DNA/RNA Extraction: High-quality nucleic acids are extracted from tumor tissue or liquid biopsy samples.
- Library Preparation: DNA or RNA is fragmented, and adapters are ligated to the ends to prepare sequencing libraries.
- Sequencing: The libraries are sequenced on a high-throughput NGS platform.
- Bioinformatic Analysis: The sequencing data is analyzed to identify genetic variants, such as mutations in RB1, amplifications of CCNE1, or alterations in genes related to the PI3K or FGFR pathways.[17]

Visualizing Key Pathways and Workflows

Signaling Pathway of CDK4/6 Inhibition

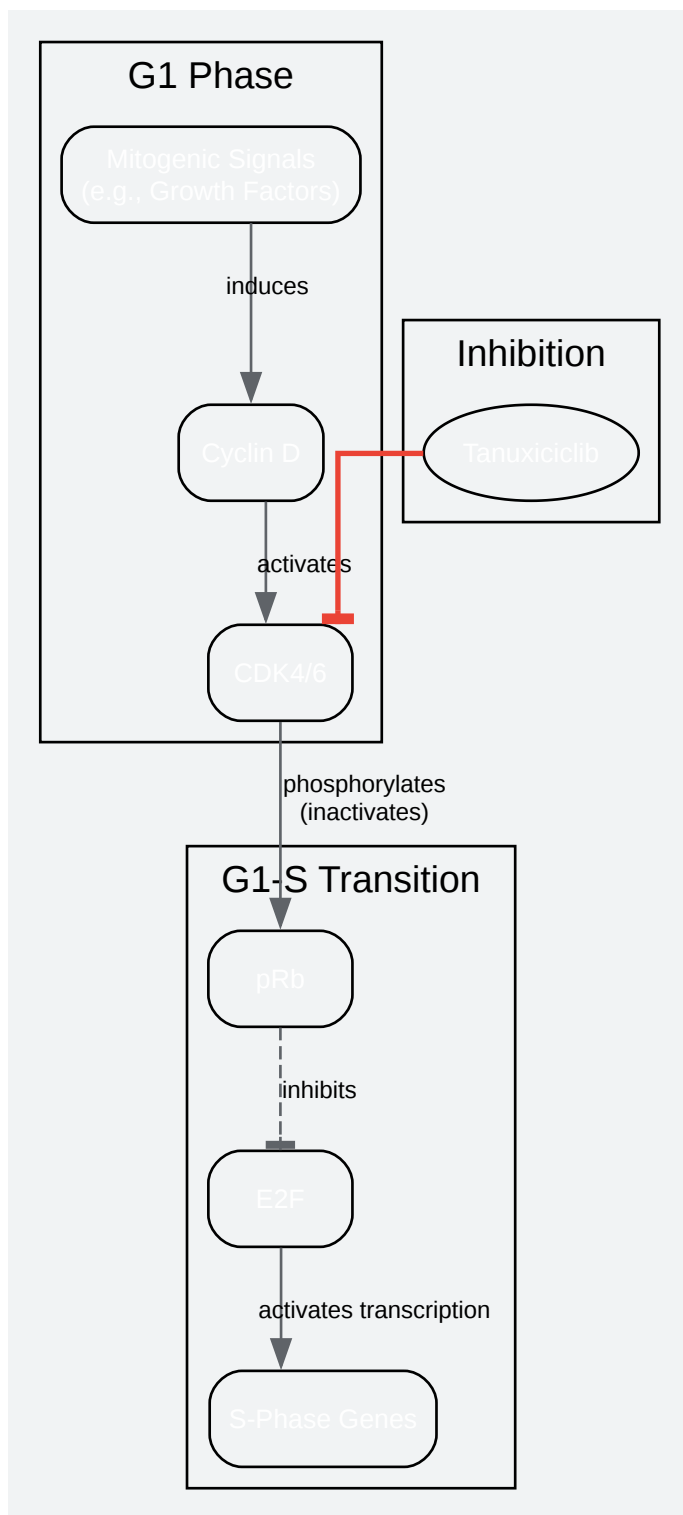

[Click to download full resolution via product page](#)

Caption: The CDK4/6-Rb pathway controlling the G1-S cell cycle transition.

Experimental Workflow for Biomarker Validation

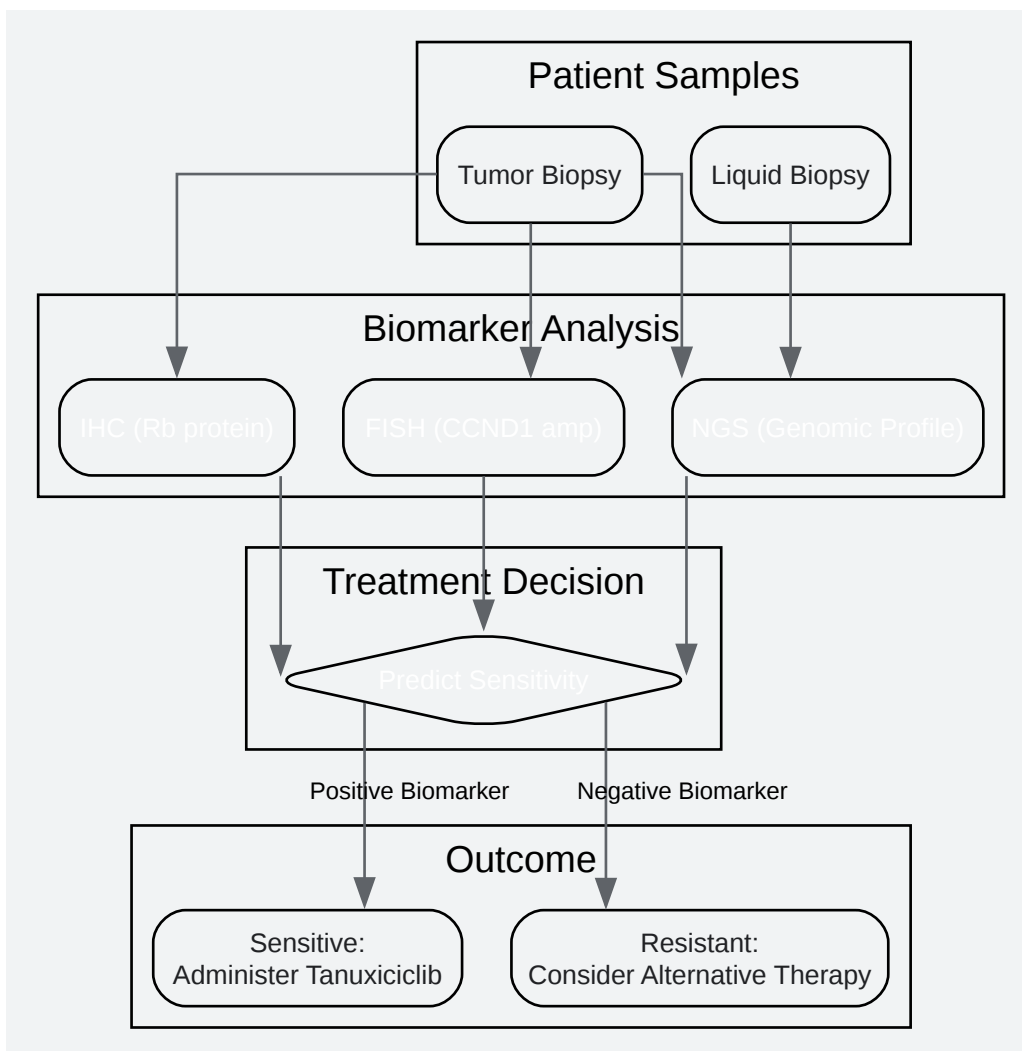

[Click to download full resolution via product page](#)

Caption: Workflow for validating and utilizing biomarkers for Tanuxiclib.

Logical Relationship of Key Biomarkers in CDK Inhibitor Resistance

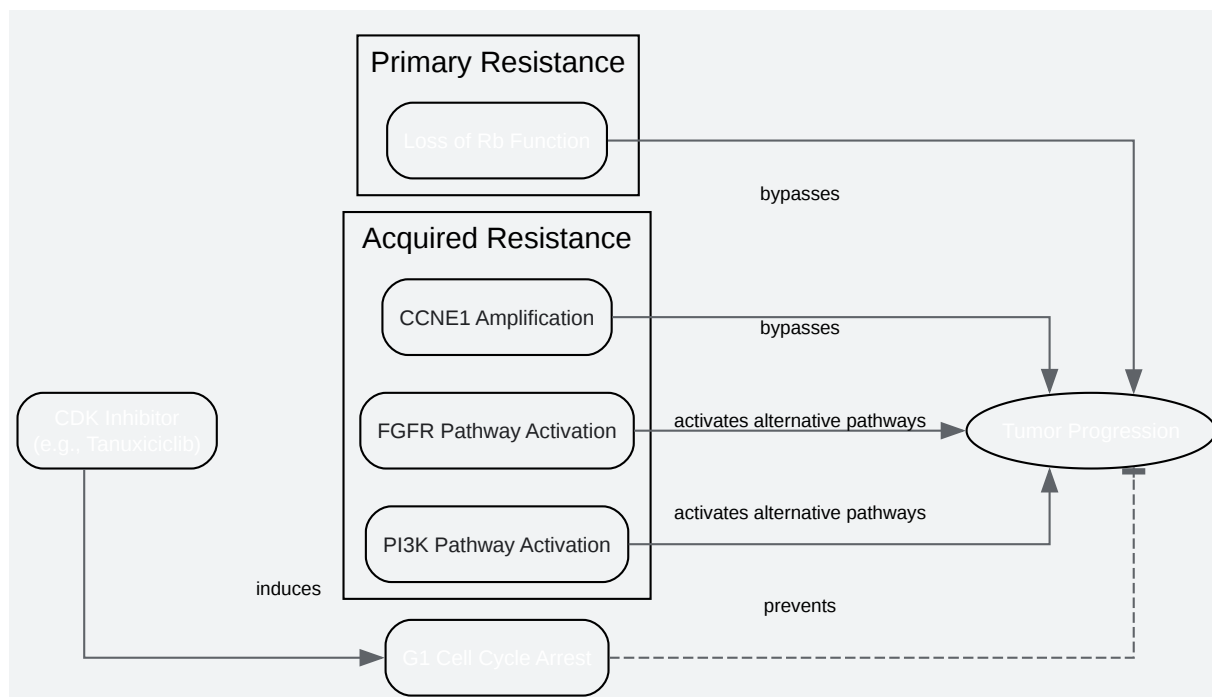

[Click to download full resolution via product page](#)

Caption: Key molecular mechanisms of resistance to CDK inhibitors.

Conclusion

The validation of predictive biomarkers is paramount for the successful clinical development and application of **Tanuxiclib trihydrochloride**. Based on the well-understood mechanism of other CDK inhibitors, a validation strategy focused on the Rb pathway, including Rb protein expression and the status of key cyclins, is strongly recommended. The experimental protocols outlined in this guide provide a robust framework for identifying patient populations most likely to benefit from Tanuxiclib therapy. As more specific data on Tanuxiclib's target profile and clinical activity become available, this guide can be further refined to incorporate more targeted biomarker discovery and validation efforts.

Need Custom Synthesis?

BenchChem offers custom synthesis for rare earth carbides and specific isotopic labeling.

Email: info@benchchem.com or [Request Quote Online](#).

References

- [1. medchemexpress.com \[medchemexpress.com\]](https://www.medchemexpress.com)
- [2. researchgate.net \[researchgate.net\]](https://www.researchgate.net)
- [3. Immunohistochemical detection of Retinoblastoma protein phosphorylation in human tumor samples - PMC \[pmc.ncbi.nlm.nih.gov\]](https://pubmed.ncbi.nlm.nih.gov/12345678/)
- [4. researchgate.net \[researchgate.net\]](https://www.researchgate.net)
- [5. zeta-corp.com \[zeta-corp.com\]](https://www.zeta-corp.com)
- [6. Rb1 \(Tumor Suppressor Protein\) Monoclonal Antibody \(RB1, 1754\) \(5925-MSM2-P1\) \[thermofisher.com\]](https://www.thermofisher.com)
- [7. Development of an optimal protocol for antigen retrieval: a 'test battery' approach exemplified with reference to the staining of retinoblastoma protein \(pRB\) in formalin-fixed paraffin sections - PubMed \[pubmed.ncbi.nlm.nih.gov\]](https://pubmed.ncbi.nlm.nih.gov/12345678/)
- [8. Detection of CCND1 Locus Amplification by Fluorescence In Situ Hybridization - PubMed \[pubmed.ncbi.nlm.nih.gov\]](https://pubmed.ncbi.nlm.nih.gov/12345678/)
- [9. Image Cytometry Diagnostic Laboratory - Our Service \[www3.mdanderson.org\]](https://www.mdanderson.org)
- [10. IGH-CCND1 Dual Fusion/Translocation FISH Probe Kit - CytoTest \[cytotest.com\]](https://www.cytotest.com)
- [11. saintfrancis.com \[saintfrancis.com\]](https://www.saintfrancis.com)
- [12. FISH is more sensitive than Southern analysis at identifying increased levels of cyclin D1 gene amplified in breast cancer cell lines - PubMed \[pubmed.ncbi.nlm.nih.gov\]](https://pubmed.ncbi.nlm.nih.gov/12345678/)
- [13. Next-Generation Sequencing for Cancer Biomarker Discovery - CD Genomics \[cd-genomics.com\]](https://www.cd-genomics.com)
- [14. NGS Proves Invaluable for Biomarker Discovery \[illumina.com\]](https://www.illumina.com)
- [15. captodayonline.com \[captodayonline.com\]](https://www.captodayonline.com)
- [16. Cancer Biomarkers | NGS detection \[illumina.com\]](https://www.illumina.com)
- [17. Genetic-based biomarkers and next-generation sequencing: the future of personalized care in colorectal cancer - PMC \[pmc.ncbi.nlm.nih.gov\]](https://pubmed.ncbi.nlm.nih.gov/12345678/)

- To cite this document: BenchChem. [Biomarker Validation for Tanuxiciclib Trihydrochloride Sensitivity: A Comparative Guide]. BenchChem, [2026]. [Online PDF]. Available at: [<https://www.benchchem.com/product/b15140729/docs#biomarker-validation-for-tanuxiciclib-trihydrochloride-sensitivity-a-comparative-guide>]

Disclaimer & Data Validity:

The information provided in this document is for Research Use Only (RUO) and is strictly not intended for diagnostic or therapeutic procedures. While BenchChem strives to provide accurate protocols, we make no warranties, express or implied, regarding the fitness of this product for every specific experimental setup.

Technical Support: The protocols provided are for reference purposes. Unsure if this reagent suits your experiment?

Need Industrial/Bulk Grade? [Request Custom Synthesis Quote](#)

BenchChem

Our mission is to be the trusted global source of essential and advanced chemicals, empowering scientists and researchers to drive progress in science and industry.

Contact

Address: 3281 E Guasti Rd
Ontario, CA 91761, United States
Phone: (601) 213-4426
Email: info@benchchem.com

[Contact our Ph.D. Support Team for a compatibility check](#)