

Technical Support Center: Troubleshooting Low Cell Permeability of VH032-based PROTACs

Author: BenchChem Technical Support Team. **Date:** April 2026

Compound of Interest

Compound Name: VH032-C4-NH-Boc

Cat. No.: B15139098

[Get Quote](#)

This technical support center provides researchers, scientists, and drug development professionals with troubleshooting guides and frequently asked questions (FAQs) to address challenges associated with the low cell permeability of VH032-based Proteolysis Targeting Chimeras (PROTACs).

Frequently Asked Questions (FAQs)

Q1: Why do my VH032-based PROTACs exhibit low cell permeability?

A1: VH032-based PROTACs, like many other PROTACs, often possess physicochemical properties that hinder their ability to efficiently cross cellular membranes. These properties typically include a high molecular weight (often exceeding 800 Da), a large polar surface area (PSA), and a significant number of hydrogen bond donors and acceptors.[1][2][3] These characteristics are outside the typical range of orally bioavailable small molecule drugs, as described by Lipinski's Rule of Five, leading to poor passive diffusion across the lipid bilayer of the cell membrane.[3]

Q2: What is the "hook effect" and how does it relate to PROTAC permeability?

A2: The "hook effect" describes a phenomenon where the degradation of the target protein decreases at high concentrations of a PROTAC. This occurs because at excessive concentrations, the PROTAC is more likely to form binary complexes with either the target protein or the E3 ligase, rather than the productive ternary complex required for degradation. While not directly a measure of permeability, poor permeability can lead researchers to use higher concentrations of the PROTAC to achieve a cellular response, potentially leading to the hook effect and confounding experimental results.

Q3: How can I assess the cell permeability of my VH032-based PROTAC?

A3: Several in vitro assays can be employed to evaluate the cell permeability of your PROTACs. The most common methods are the Parallel Artificial Membrane Permeability Assay (PAMPA) and the Caco-2 permeability assay.[1][4][5] PAMPA is a high-throughput, cell-free assay that measures passive diffusion across an artificial lipid membrane, providing a measure of a compound's intrinsic permeability.[6] The Caco-2 assay utilizes a monolayer of human intestinal cells and provides a more comprehensive assessment by considering passive diffusion, active transport, and efflux mechanisms.[4][7] Additionally, measuring the intracellular concentration of the PROTAC using techniques like liquid chromatography-mass spectrometry (LC-MS) can provide a direct measure of cell penetration.[8][9]

Q4: Can the linker connecting the VH032 ligand and the target protein binder influence cell permeability?

A4: Yes, the linker plays a crucial role in determining the overall physicochemical properties of the PROTAC and, consequently, its cell permeability.[3] Linker length, rigidity, and composition can significantly impact the PROTAC's ability to adopt conformations that are more favorable for membrane crossing.[10][11] For instance, linkers that promote intramolecular hydrogen bonding can effectively "shield" polar groups, reducing the polar surface area and enhancing permeability.[11] Replacing flexible polyethylene glycol (PEG) linkers with more rigid alkyl or phenyl-containing linkers has been shown to improve cellular permeability in some cases.

Troubleshooting Guides

Problem: My VH032-based PROTAC is potent in biochemical assays but shows weak or no activity in

cell-based assays.

This is a common issue often attributed to poor cell permeability. The following steps can help you troubleshoot and address this problem.

Step 1: Confirm Target Engagement in Cells Before concluding that low permeability is the sole issue, it is essential to confirm that your PROTAC can engage its intended target protein and the VHL E3 ligase within the cellular environment.

- **Recommended Experiment:** Cellular Thermal Shift Assay (CETSA) or NanoBRET™ Target Engagement Assays. These assays can verify target binding in intact cells.

Step 2: Assess Cell Permeability If target engagement is confirmed, the next step is to directly measure the permeability of your PROTAC.

- **Recommended Experiments:**
 - **Parallel Artificial Membrane Permeability Assay (PAMPA):** To assess passive permeability.
 - **Caco-2 Permeability Assay:** To evaluate passive and active transport, as well as efflux.
 - **Intracellular Concentration Measurement by LC-MS:** To directly quantify the amount of PROTAC that enters the cells.

Step 3: Strategies to Improve Cell Permeability Based on the results from the permeability assays, you can employ several strategies to enhance the cell permeability of your VH032-based PROTAC.

- **Linker Optimization:**
 - **Vary Linker Length:** Synthesize a series of PROTACs with different linker lengths. Shorter linkers can sometimes lead to more compact structures with improved permeability.
 - **Increase Linker Rigidity:** Replace flexible PEG linkers with more rigid moieties like alkyl chains or aromatic rings. This can reduce the conformational flexibility and favor a more permeable state.

- **Modify Linker Composition:** Introduce atoms or groups that can form intramolecular hydrogen bonds, effectively reducing the molecule's polar surface area.
- **Amide-to-Ester Substitution:**
 - Replacing an amide bond in the linker or at the junction with the VH032 ligand or the target binder with an ester can reduce the number of hydrogen bond donors and increase lipophilicity, often leading to improved permeability.[\[12\]](#)[\[13\]](#)[\[14\]](#)[\[15\]](#)
- **Prodrug Approach:**
 - Mask polar functional groups on the PROTAC with lipophilic moieties that can be cleaved by intracellular enzymes to release the active PROTAC. This can significantly enhance cell uptake.

Data Presentation: Impact of Structural Modifications on Permeability

The following tables summarize quantitative data on how specific structural modifications can impact the permeability of VH032-based PROTACs.

Table 1: Effect of Linker Composition on PAMPA Permeability

PROTAC Compound	Linker Composition	PAMPA Pe (10 ⁻⁶ cm/s)	Reference
Compound A	3-unit PEG	0.2	[1]
Compound B	Alkyl chain	0.002	[1] [2]
Compound C	Phenyl ring	Improved permeability vs. PEG	[16]

Table 2: Effect of Amide-to-Ester Substitution on PAMPA Permeability

PROTAC Pair	Modification	PAMPA Pe (10-6 cm/s)	Fold Increase in Permeability	Reference
MZ1 (Amide)	-	~0.03	-	[12][13]
OMZ1 (Ester)	Amide to Ester	~0.3	10	[12][13]
ARV-771 (Amide)	-	~0.2	-	[12][13]
OARV-771 (Ester)	Amide to Ester	~0.3	1.5	[12][13]
AB2 (Amide)	-	~0.08	-	[12][13]
OAB2 (Ester)	Amide to Ester	~0.6	7.5	[12][13]

Experimental Protocols

Protocol 1: Parallel Artificial Membrane Permeability Assay (PAMPA)

This protocol provides a general procedure for assessing the passive permeability of VH032-based PROTACs.

Materials:

- 96-well filter plates (e.g., Millipore MultiScreen-IP)
- 96-well acceptor plates
- Phospholipid solution (e.g., 2% (w/v) lecithin in dodecane)
- Phosphate-buffered saline (PBS), pH 7.4
- PROTAC stock solution (e.g., 10 mM in DMSO)
- UV-Vis spectrophotometer or LC-MS system

Procedure:

- Prepare the Donor Plate: Carefully add 5 μL of the phospholipid solution to each well of the filter plate, ensuring the filter is completely coated.
- Prepare the Acceptor Plate: Add 300 μL of PBS to each well of the acceptor plate.
- Prepare PROTAC Solutions: Dilute the PROTAC stock solution in PBS to the desired final concentration (e.g., 100 μM).
- Assemble the PAMPA Sandwich: Carefully place the donor filter plate on top of the acceptor plate, ensuring the bottom of the filter makes contact with the PBS in the acceptor plate.
- Add PROTAC to Donor Plate: Add 150 μL of the PROTAC solution to each well of the donor plate.
- Incubation: Cover the plate assembly and incubate at room temperature for 4-16 hours with gentle shaking.
- Analysis: After incubation, carefully separate the plates. Determine the concentration of the PROTAC in both the donor and acceptor wells using a suitable analytical method (UV-Vis or LC-MS).
- Calculate Permeability (P_e): The effective permeability is calculated using the following equation: $P_e = - (V_D * V_A) / ((V_D + V_A) * A * t) * \ln(1 - [CA]_t / C_{eq})$ Where V_D and V_A are the volumes of the donor and acceptor wells, A is the filter area, t is the incubation time, $[CA]_t$ is the concentration in the acceptor well at time t , and C_{eq} is the equilibrium concentration.

Protocol 2: Caco-2 Permeability Assay

This protocol outlines the steps for assessing PROTAC permeability across a Caco-2 cell monolayer.

Materials:

- Caco-2 cells
- Transwell inserts (e.g., 24-well format)
- Cell culture medium (e.g., DMEM with 10% FBS)

- Hanks' Balanced Salt Solution (HBSS)
- PROTAC stock solution (e.g., 10 mM in DMSO)
- LC-MS system

Procedure:

- Cell Seeding and Differentiation: Seed Caco-2 cells onto the Transwell inserts and culture for 21-25 days to allow for differentiation and formation of a confluent monolayer with tight junctions.
- Monolayer Integrity Check: Measure the transepithelial electrical resistance (TEER) of the monolayer to ensure its integrity.
- Prepare PROTAC Dosing Solution: Dilute the PROTAC stock solution in HBSS to the final desired concentration (e.g., 10 μ M).
- Permeability Measurement (Apical to Basolateral - A to B): a. Wash the Caco-2 monolayers with pre-warmed HBSS. b. Add the PROTAC dosing solution to the apical (upper) chamber. c. Add fresh HBSS to the basolateral (lower) chamber. d. Incubate at 37°C with gentle shaking. e. At various time points (e.g., 30, 60, 90, 120 minutes), take samples from the basolateral chamber and replace with fresh HBSS.
- Permeability Measurement (Basolateral to Apical - B to A): a. Perform the same procedure as above but add the PROTAC dosing solution to the basolateral chamber and sample from the apical chamber.
- Analysis: Analyze the concentration of the PROTAC in the collected samples by LC-MS.
- Calculate Apparent Permeability (P_{app}): The apparent permeability is calculated using the following equation: $P_{app} = (dQ/dt) / (A * C_0)$ Where dQ/dt is the rate of PROTAC appearance in the receiver chamber, A is the surface area of the membrane, and C_0 is the initial concentration in the donor chamber.
- Calculate Efflux Ratio: The efflux ratio is calculated as $P_{app} (B \text{ to } A) / P_{app} (A \text{ to } B)$. An efflux ratio greater than 2 suggests active efflux.[4]

Protocol 3: Intracellular Concentration Measurement by LC-MS

This protocol describes how to quantify the intracellular concentration of a VH032-based PROTAC.

Materials:

- Cultured cells of interest
- PROTAC stock solution
- Ice-cold PBS
- Lysis buffer (e.g., RIPA buffer with protease inhibitors)
- Acetonitrile with an internal standard
- LC-MS system

Procedure:

- **Cell Treatment:** Seed cells in a culture plate and treat with the desired concentration of the PROTAC for a specific time (e.g., 2-4 hours).
- **Cell Harvesting:** a. Remove the medium and wash the cells three times with ice-cold PBS to remove any extracellular PROTAC. b. Lyse the cells directly in the plate with lysis buffer. c. Scrape the cells and collect the lysate.
- **Protein Precipitation:** a. Add three volumes of cold acetonitrile containing a suitable internal standard to the cell lysate. b. Vortex and incubate at -20°C for 30 minutes to precipitate proteins. c. Centrifuge at high speed (e.g., 14,000 rpm) for 10 minutes at 4°C .
- **Sample Analysis:** a. Collect the supernatant and analyze it using a validated LC-MS/MS method to quantify the concentration of the PROTAC.
- **Data Normalization:** a. Determine the protein concentration of the cell lysate using a BCA or similar assay. b. Normalize the measured PROTAC concentration to the total protein amount

to determine the intracellular concentration (e.g., in pmol/mg of protein).

Mandatory Visualizations

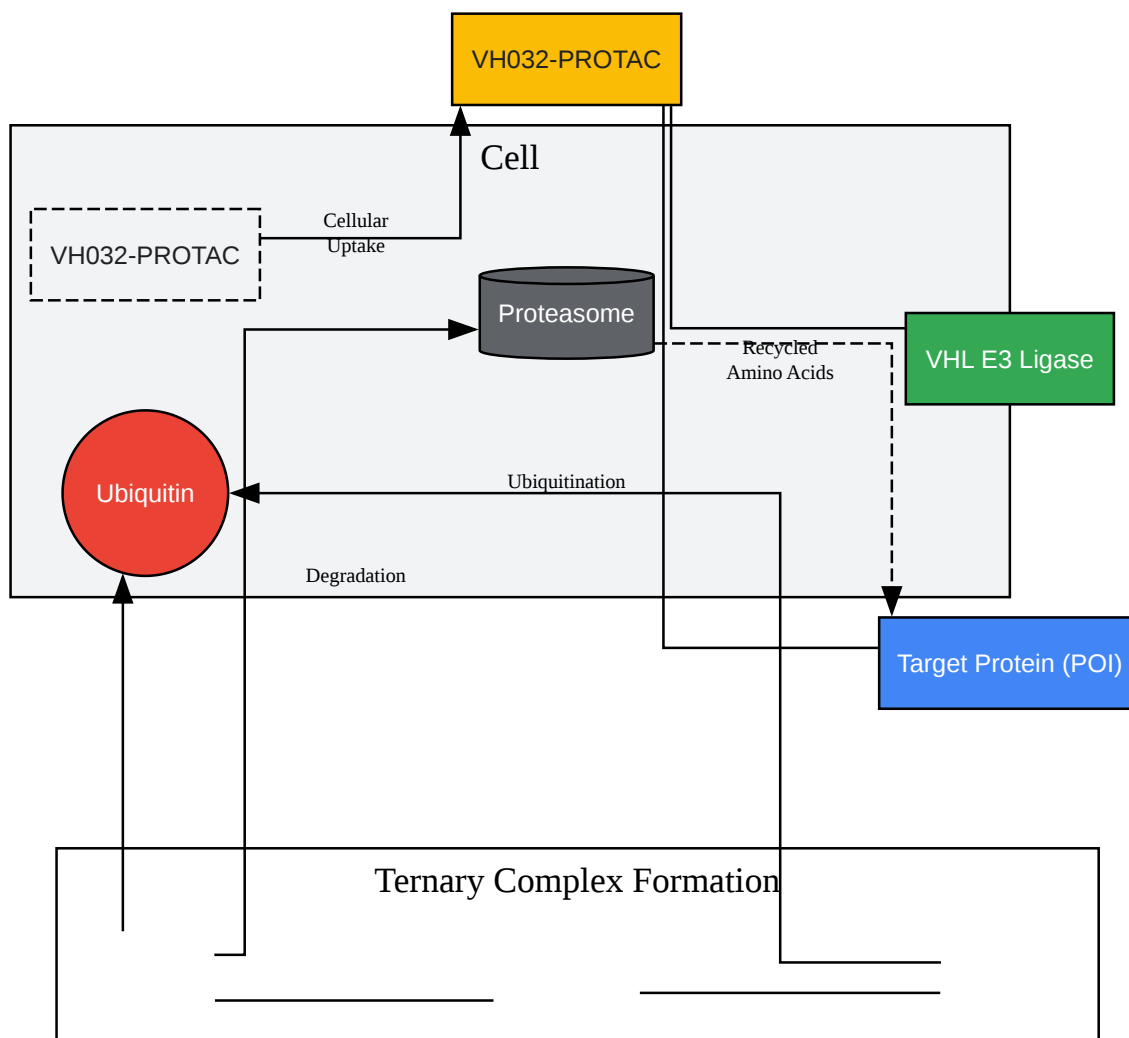

[Click to download full resolution via product page](#)

Caption: Mechanism of action of a VH032-based PROTAC.

Caption: Troubleshooting workflow for low cellular activity.

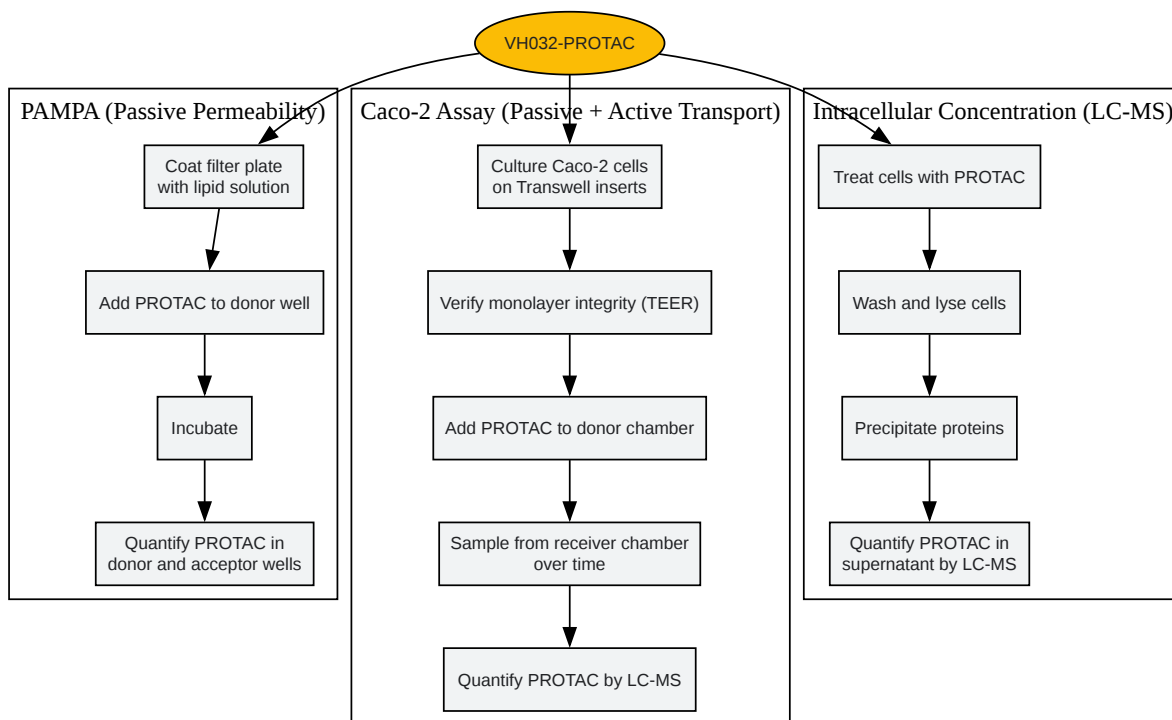

[Click to download full resolution via product page](#)

Caption: Experimental workflows for assessing permeability.

Need Custom Synthesis?

BenchChem offers custom synthesis for rare earth carbides and specific isotopic labeling.

Email: info@benchchem.com or [Request Quote Online](#).

References

- [1. pubs.acs.org \[pubs.acs.org\]](https://pubs.acs.org)

- [2. Understanding and Improving the Membrane Permeability of VH032-Based PROTACs - PMC \[pmc.ncbi.nlm.nih.gov\]](#)
- [3. Frontiers | From Conception to Development: Investigating PROTACs Features for Improved Cell Permeability and Successful Protein Degradation \[frontiersin.org\]](#)
- [4. enamine.net \[enamine.net\]](#)
- [5. From Conception to Development: Investigating PROTACs Features for Improved Cell Permeability and Successful Protein Degradation - PMC \[pmc.ncbi.nlm.nih.gov\]](#)
- [6. benchchem.com \[benchchem.com\]](#)
- [7. Systematic Investigation of the Permeability of Androgen Receptor PROTACs - PMC \[pmc.ncbi.nlm.nih.gov\]](#)
- [8. researchgate.net \[researchgate.net\]](#)
- [9. Assays and technologies for developing proteolysis targeting chimera degraders - PMC \[pmc.ncbi.nlm.nih.gov\]](#)
- [10. researchgate.net \[researchgate.net\]](#)
- [11. pubs.acs.org \[pubs.acs.org\]](#)
- [12. scispace.com \[scispace.com\]](#)
- [13. pubs.acs.org \[pubs.acs.org\]](#)
- [14. chemrxiv.org \[chemrxiv.org\]](#)
- [15. discovery.dundee.ac.uk \[discovery.dundee.ac.uk\]](#)
- [16. researchgate.net \[researchgate.net\]](#)
- [To cite this document: BenchChem. \[Technical Support Center: Troubleshooting Low Cell Permeability of VH032-based PROTACs\]. BenchChem, \[2026\]. \[Online PDF\]. Available at: \[https://www.benchchem.com/product/b15139098/docs#technical-support-center-troubleshooting-low-cell-permeability-of-vh032-based-protacs\]](#)

Disclaimer & Data Validity:

The information provided in this document is for Research Use Only (RUO) and is strictly not intended for diagnostic or therapeutic procedures. While BenchChem strives to provide accurate protocols, we make no warranties, express or implied, regarding the fitness of this product for every specific experimental setup.

Technical Support: The protocols provided are for reference purposes. Unsure if this reagent suits your experiment?

Need Industrial/Bulk Grade? [Request Custom Synthesis Quote](#)

BenchChem

Our mission is to be the trusted global source of essential and advanced chemicals, empowering scientists and researchers to drive progress in science and industry.

Contact

Address: 3281 E Guasti Rd
Ontario, CA 91761, United States
Phone: (601) 213-4426
Email: info@benchchem.com

[Contact our Ph.D. Support Team for a compatibility check](#)