

Technical Support Center: Optimizing EML734 Concentration for IC50 Determination

Author: BenchChem Technical Support Team. **Date:** April 2026

Compound of Interest

Compound Name: EML734
Cat. No.: B15584696

[Get Quote](#)

This technical support center provides researchers, scientists, and drug development professionals with comprehensive guidance on optimizing the concentration of **EML734** for accurate half-maximal inhibitory concentration (IC50) determination. Below you will find frequently asked questions (FAQs), detailed troubleshooting guides, and experimental protocols to ensure the generation of reliable and reproducible data.

Frequently Asked Questions (FAQs)

Q1: What is **EML734** and what is its mechanism of action?

A1: **EML734** is an investigational inhibitor targeting the Hedgehog signaling pathway. This pathway is crucial in embryonic development and can be aberrantly activated in various cancers, contributing to tumor growth and survival.[1][2] **EML734** specifically targets a key component of this pathway, leading to the downstream suppression of Gli transcription factors and the inhibition of cancer cell proliferation.

Q2: What is the expected IC50 range for **EML734**?

A2: The IC50 value for **EML734** is highly dependent on the specific cancer cell line being tested and the duration of the assay. For cell lines with a constitutively active Hedgehog

pathway, IC50 values are expected to be in the nanomolar to low micromolar range. It is essential to perform a preliminary dose-response experiment to determine the optimal concentration range for your specific model.

Q3: Why are my **EML734** IC50 values inconsistent across experiments?

A3: Inconsistent IC50 values are a common issue in pharmacological studies and can stem from various factors.^{[3][4]} Key variables that can influence IC50 outcomes include cell passage number, cell seeding density, serum concentration in the media, and the precise duration of drug incubation.^{[4][5]} Meticulous control of these experimental parameters is critical for reproducibility.

Q4: How do I select the initial concentration range for my IC50 experiment?

A4: For a new compound like **EML734**, it is recommended to start with a broad concentration range, spanning several orders of magnitude (e.g., 1 nM to 100 μ M), to capture the full dose-response curve.^[6] A typical approach involves using a 3-fold or 10-fold serial dilution to create 8 to 12 different concentrations.^{[6][7]}

Q5: How many replicates should be used for each concentration?

A5: To ensure statistical significance and reliability of your results, it is recommended to use a minimum of three technical replicates for each **EML734** concentration.^[6]

Signaling Pathway

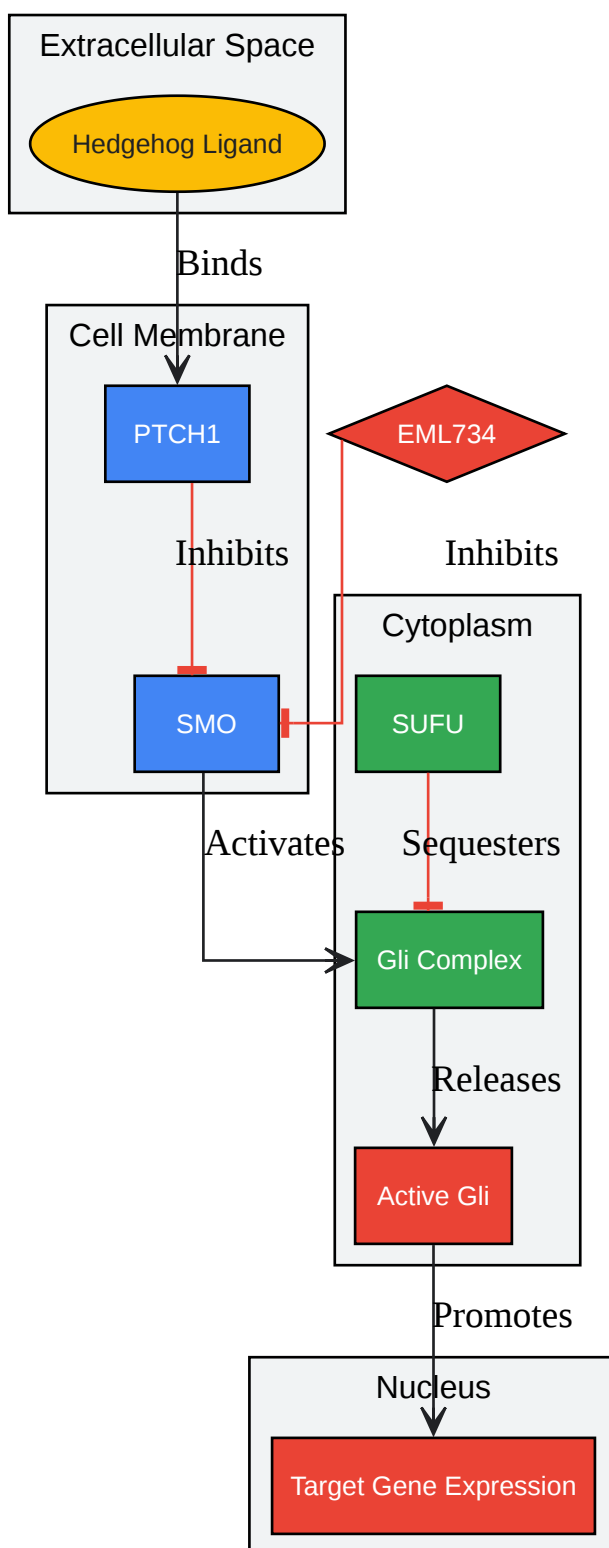

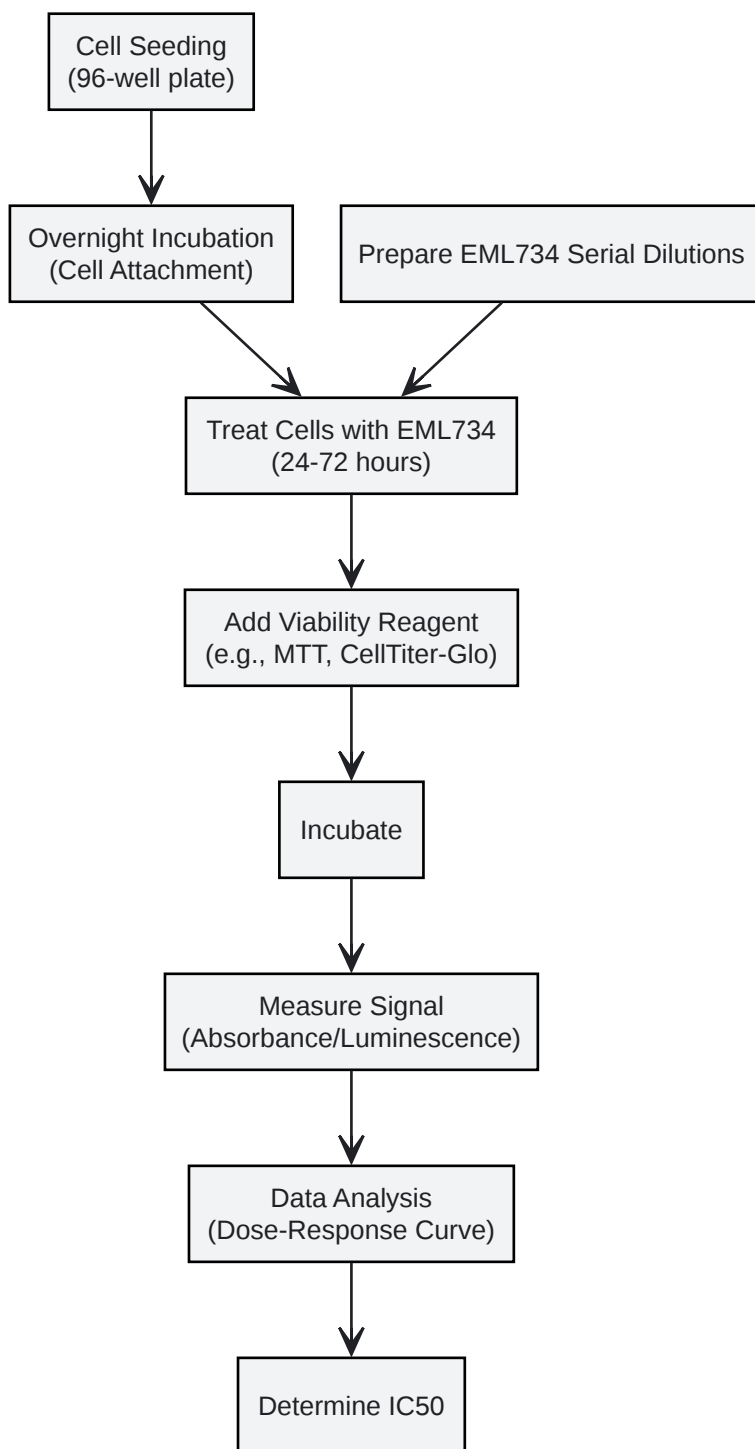

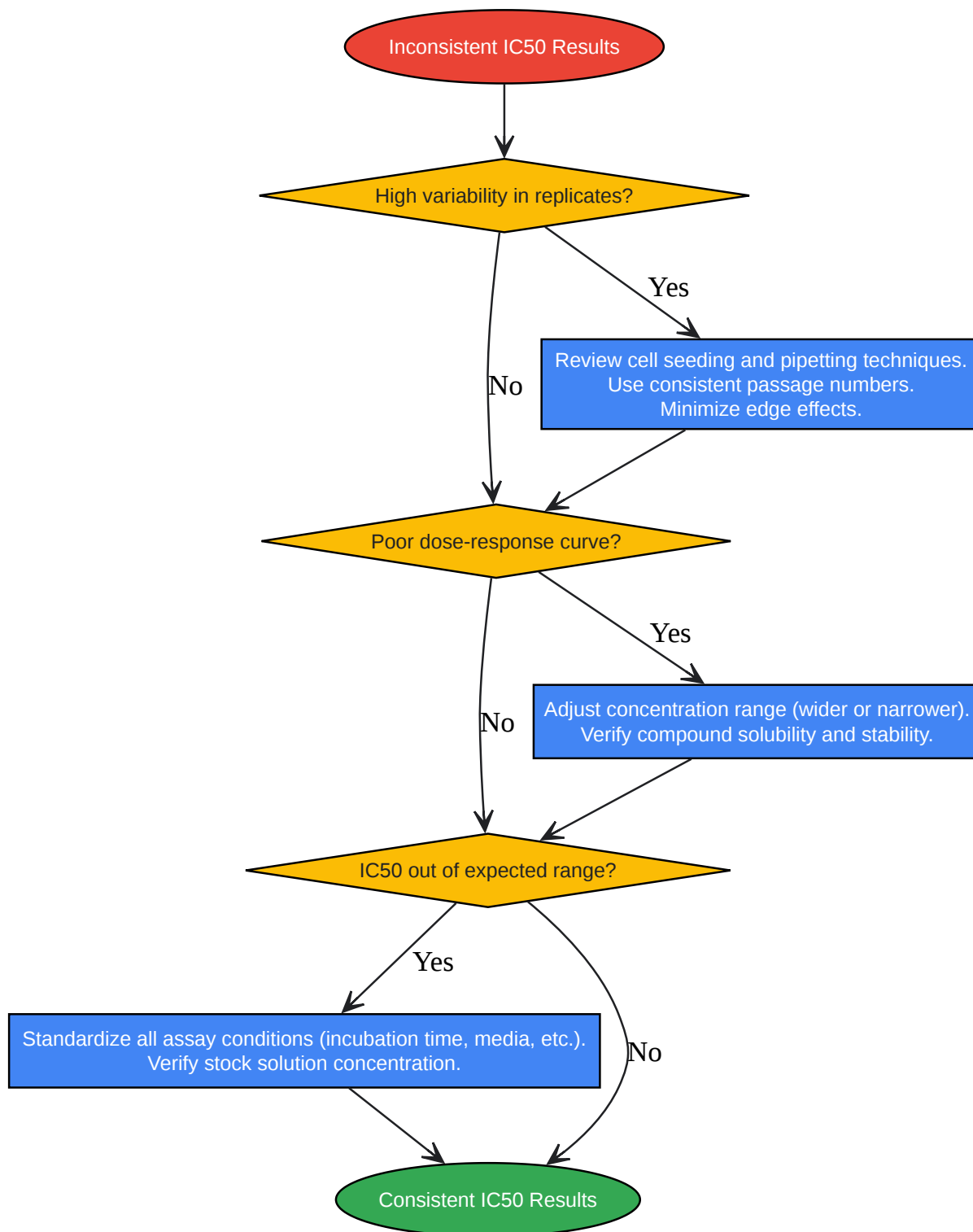

[Click to download full resolution via product page](#)

Need Custom Synthesis?

BenchChem offers custom synthesis for rare earth carbides and specific isotopic labeling.

Email: info@benchchem.com or [Request Quote Online](#).

References

- [1. mdpi.com \[mdpi.com\]](#)
- [2. mdpi.com \[mdpi.com\]](#)
- [3. smart.dhgate.com \[smart.dhgate.com\]](#)
- [4. benchchem.com \[benchchem.com\]](#)
- [5. benchchem.com \[benchchem.com\]](#)
- [6. benchchem.com \[benchchem.com\]](#)
- [7. researchgate.net \[researchgate.net\]](#)
- To cite this document: BenchChem. [Technical Support Center: Optimizing EML734 Concentration for IC50 Determination]. BenchChem, [2026]. [Online PDF]. Available at: [<https://www.benchchem.com/product/b15584696/docs#technical-support-center-optimizing-eml734-concentration-for-ic50-determination>]

Disclaimer & Data Validity:

The information provided in this document is for Research Use Only (RUO) and is strictly not intended for diagnostic or therapeutic procedures. While BenchChem strives to provide accurate protocols, we make no warranties, express or implied, regarding the fitness of this product for every specific experimental setup.

Technical Support: The protocols provided are for reference purposes. Unsure if this reagent suits your experiment?

Need Industrial/Bulk Grade? [Request Custom Synthesis Quote](#)

BenchChem

Our mission is to be the trusted global source of essential and advanced chemicals, empowering scientists and researchers to drive progress in science and industry.

Contact

Address: 3281 E Guasti Rd

Ontario, CA 91761, United States

Phone: (601) 213-4426

Email: info@benchchem.com

[Contact our Ph.D. Support Team for a compatibility check](#)