

# minimizing experimental artifacts with LSN3160440

**Author:** BenchChem Technical Support Team. **Date:** April 2026

## Compound of Interest

Compound Name: LSN3160440

Cat. No.: B15138572

[Get Quote](#)

## LSN3160440 Technical Support Center

Welcome to the technical support center for **LSN3160440**, a positive allosteric modulator (PAM) of the glucagon-like peptide-1 receptor (GLP-1R). This resource is designed to assist researchers, scientists, and drug development professionals in minimizing experimental artifacts and effectively utilizing **LSN3160440** in their studies.

## Frequently Asked Questions (FAQs)

Q1: What is the mechanism of action of **LSN3160440**?

A1: **LSN3160440** is a positive allosteric modulator (PAM) of the GLP-1 receptor. It functions as a "molecular glue" by stabilizing the interaction between the GLP-1R and its inactive metabolite, GLP-1(9-36)NH<sub>2</sub>.<sup>[1]</sup> This interaction potentiates the activity of GLP-1(9-36)NH<sub>2</sub>, effectively converting it from a weak partial agonist to a full agonist.<sup>[2]</sup> **LSN3160440** binds to a site topographically distinct from the orthosteric ligand binding pocket, at the interface of transmembrane helices 1 and 2 (TM1 and TM2).<sup>[3][4]</sup>

Q2: What is "probe dependency" and how does it apply to **LSN3160440**?

A2: Probe dependency is a phenomenon observed with allosteric modulators where the modulator's effect is dependent on the specific orthosteric ligand ("probe") it is paired with.

**LSN3160440** exhibits strong probe dependence, robustly potentiating the activity of GLP-1(9-36)NH<sub>2</sub> but not the full-length, active form of GLP-1 (GLP-1(7-36)NH<sub>2</sub>) or oxyntomodulin.[5] This specificity is a critical consideration in experimental design.

Q3: What are the known off-target effects of **LSN3160440**?

A3: **LSN3160440** was developed from a screening hit that was a known MET kinase inhibitor. However, through optimization, **LSN3160440** has been shown to be highly selective. It displays selectivity against the MET kinase and a panel of 33 other diverse kinases, as well as 261 G-protein coupled receptors (GPCRs).[5] While off-target effects are minimal, it is always good practice to include appropriate controls in your experiments to monitor for any unexpected activity.

Q4: What are the recommended solvent and storage conditions for **LSN3160440**?

A4: **LSN3160440** is soluble in DMSO. For long-term storage, it is recommended to store the compound as a solid at -20°C. For experimental use, fresh dilutions from a DMSO stock solution should be prepared. Studies on the stability of compounds in DMSO suggest that while many are stable, the presence of water can be a more significant factor in compound degradation than oxygen.[6] It is advisable to use anhydrous DMSO and minimize freeze-thaw cycles.

## Troubleshooting Guides

### In Vitro Assays

Issue 1: Low or no signal in cAMP accumulation assays.

Potential Cause	Troubleshooting Step
Low GLP-1R Expression	Confirm GLP-1R expression in your cell line using qPCR or Western blot. Consider using a cell line with higher endogenous expression or a stably transfected cell line.
cAMP Degradation	Include a phosphodiesterase (PDE) inhibitor, such as IBMX (100-500 $\mu$ M), in your assay buffer to prevent the breakdown of cAMP.[7]
Suboptimal Stimulation Time	Perform a time-course experiment to determine the peak cAMP response time for your specific cell line and experimental conditions.
LSN3160440 or GLP-1(9-36)NH <sub>2</sub> Degradation	Prepare fresh dilutions of both LSN3160440 and GLP-1(9-36)NH <sub>2</sub> for each experiment from frozen stocks.
Incorrect Assay Conditions	Ensure the assay is performed in the presence of GLP-1(9-36)NH <sub>2</sub> , as LSN3160440's potentiation is probe-dependent.

Issue 2: High background or variability in insulin secretion assays from isolated islets.

Potential Cause	Troubleshooting Step
Islet Health and Viability	Ensure proper islet isolation technique to maximize viability. Allow islets to recover for at least 2 hours post-isolation before starting the experiment.
Basal Insulin Secretion	Pre-incubate islets in low-glucose media to establish a stable baseline before stimulation.[8]
Inconsistent Islet Size	Hand-pick islets of similar size for each experimental replicate to reduce variability in insulin content.
Reagent Purity	Use high-purity glucose and other reagents. Ensure the GLP-1(9-36)NH <sub>2</sub> peptide is of high quality and stored correctly.
Glucose-Dependent Effect	Remember that LSN3160440's potentiation of insulin secretion is glucose-dependent.[9] Ensure appropriate low and high glucose concentrations are used as controls.

## In Vivo Assays

Issue 3: Poor in vivo efficacy or high variability in animal studies.

Potential Cause	Troubleshooting Step
Poor Bioavailability	LSN3160440 has been successfully administered via oral gavage.[10][11] Ensure proper vehicle formulation to aid absorption. A common vehicle for oral administration of hydrophobic compounds is a suspension in 0.5% carboxymethylcellulose (CMC) in water. For injections, a mixture of DMSO and corn oil (e.g., 10:90) can be considered.[12]
Incorrect Dosing	Perform a dose-response study to determine the optimal concentration of LSN3160440 for your animal model and desired effect.
Timing of Administration	The timing of LSN3160440 administration relative to the glucose challenge or other stimuli is critical. This should be optimized based on the pharmacokinetic profile of the compound.
Animal Stress	Handle animals carefully to minimize stress, which can impact glucose homeostasis and introduce variability.
Probe Availability	Ensure that the experimental design accounts for the endogenous levels of GLP-1(9-36)NH <sub>2</sub> in the animal model, as this is the probe that LSN3160440 potentiates.

## Experimental Protocols

### Protocol 1: In Vitro cAMP Accumulation Assay

- Cell Culture: Plate HEK293 cells stably expressing the human GLP-1R in a 96-well plate at a density of 50,000 cells/well and culture overnight.
- Assay Buffer Preparation: Prepare an assay buffer (e.g., HBSS) containing a phosphodiesterase inhibitor such as 500  $\mu$ M IBMX.

- **Compound Preparation:** Prepare serial dilutions of **LSN3160440** in the assay buffer. Prepare a fixed, sub-maximal concentration of GLP-1(9-36)NH<sub>2</sub> (e.g., EC<sub>20</sub>) in the assay buffer.
- **Stimulation:** Wash the cells once with assay buffer. Add the **LSN3160440** dilutions to the wells, followed immediately by the addition of GLP-1(9-36)NH<sub>2</sub>. Include control wells with vehicle, **LSN3160440** alone, and GLP-1(9-36)NH<sub>2</sub> alone.
- **Incubation:** Incubate the plate at 37°C for 30 minutes.
- **Lysis and Detection:** Lyse the cells and measure intracellular cAMP levels using a commercially available cAMP assay kit (e.g., HTRF, ELISA) according to the manufacturer's instructions.

## Protocol 2: Glucose-Stimulated Insulin Secretion (GSIS) from Isolated Mouse Islets

- **Islet Isolation:** Isolate pancreatic islets from mice using collagenase digestion.
- **Islet Recovery:** Allow islets to recover for 2 hours in RPMI-1640 medium supplemented with 10% FBS and 11 mM glucose.
- **Pre-incubation:** Hand-pick islets of similar size and place 10 islets per well in a 24-well plate. Pre-incubate for 1 hour at 37°C in Krebs-Ringer Bicarbonate (KRB) buffer containing 2.8 mM glucose.
- **Stimulation:** Replace the pre-incubation buffer with KRB buffer containing:
  - 2.8 mM glucose (basal)
  - 16.7 mM glucose (stimulated)
  - 16.7 mM glucose + **LSN3160440**
  - 16.7 mM glucose + GLP-1(9-36)NH<sub>2</sub>
  - 16.7 mM glucose + **LSN3160440** + GLP-1(9-36)NH<sub>2</sub>
- **Incubation:** Incubate for 1 hour at 37°C.

- **Sample Collection:** Collect the supernatant from each well.
- **Insulin Measurement:** Measure the insulin concentration in the supernatant using an ELISA kit.

## Quantitative Data Summary

Table 1: In Vitro Potency of **LSN3160440**

Assay	Ligand	Condition	EC50 / Ki (nM)
cAMP Accumulation	GLP-1(9-36)NH2	+ 1 $\mu$ M LSN3160440	~1
cAMP Accumulation	GLP-1(9-36)NH2	- LSN3160440	>1000
Radioligand Binding	GLP-1(9-36)NH2	+ 10 $\mu$ M LSN3160440	0.77
Radioligand Binding	GLP-1(9-36)NH2	- LSN3160440	105

Note: The above values are approximate and may vary depending on the specific experimental conditions.

## Visualizations

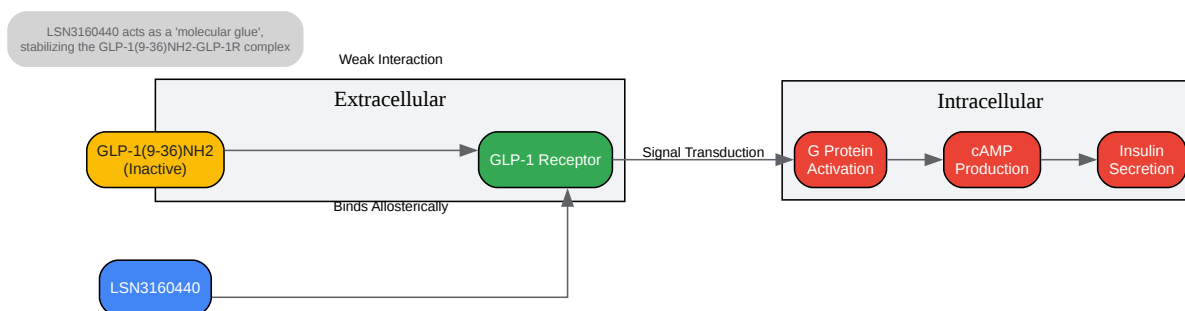

[Click to download full resolution via product page](#)

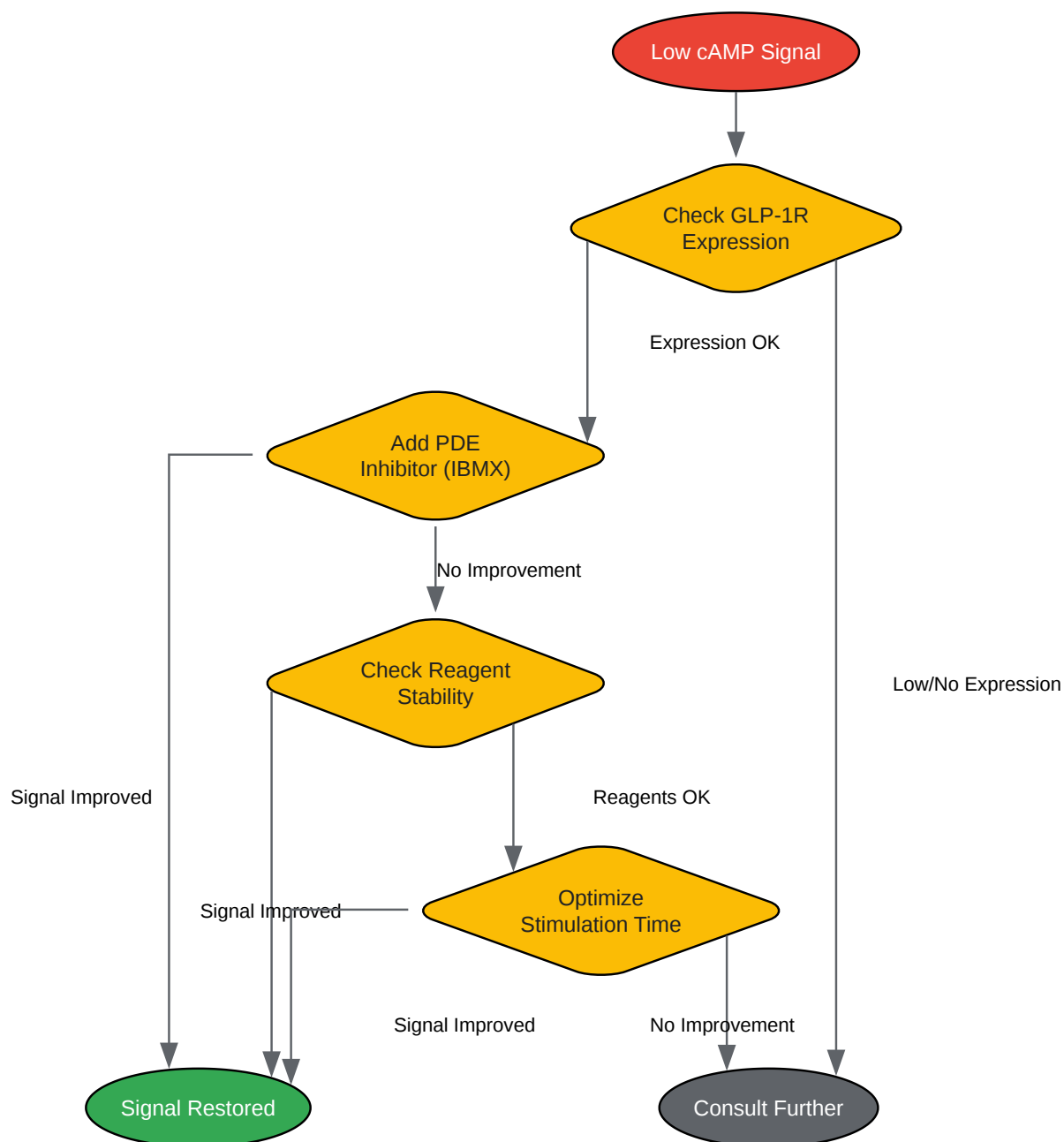
Caption: Mechanism of action of **LSN3160440** as a molecular glue.

[Click to download full resolution via product page](#)

Caption: Troubleshooting workflow for low cAMP signal.

### Need Custom Synthesis?

BenchChem offers custom synthesis for rare earth carbides and specific isotopic labeling.

Email: [info@benchchem.com](mailto:info@benchchem.com) or [Request Quote Online](#).

## References

- [1. medchemexpress.com \[medchemexpress.com\]](https://www.medchemexpress.com)
- [2. researchgate.net \[researchgate.net\]](https://www.researchgate.net)
- [3. researchgate.net \[researchgate.net\]](https://www.researchgate.net)
- [4. Structural insights into probe-dependent positive allostereism of the GLP-1 receptor - PubMed \[pubmed.ncbi.nlm.nih.gov\]](#)
- [5. GLP1R PAM virtual screen. LSN3160440 Analogs. \[doctortarget.com\]](https://www.doctortarget.com)
- [6. Studies on repository compound stability in DMSO under various conditions - PubMed \[pubmed.ncbi.nlm.nih.gov\]](#)
- [7. benchchem.com \[benchchem.com\]](https://www.benchchem.com)
- [8. Static insulin secretion analysis of isolated islets \[protocols.io\]](https://www.protocols.io)
- [9. researchgate.net \[researchgate.net\]](https://www.researchgate.net)
- [10. Oral Gavage Delivery of Stable Isotope Tracer for In Vivo Metabolomics - PubMed \[pubmed.ncbi.nlm.nih.gov\]](#)
- [11. researchgate.net \[researchgate.net\]](https://www.researchgate.net)
- [12. LSN3160440 | Molecular Glues | 2765539-59-9 | Invivochem \[invivochem.com\]](https://www.invivochem.com)
- To cite this document: BenchChem. [minimizing experimental artifacts with LSN3160440]. BenchChem, [2026]. [Online PDF]. Available at: [\[https://www.benchchem.com/product/b15138572/docs#minimizing-experimental-artifacts-with-lsn3160440\]](https://www.benchchem.com/product/b15138572/docs#minimizing-experimental-artifacts-with-lsn3160440)

---

### Disclaimer & Data Validity:

The information provided in this document is for Research Use Only (RUO) and is strictly not intended for diagnostic or therapeutic procedures. While BenchChem strives to provide

accurate protocols, we make no warranties, express or implied, regarding the fitness of this product for every specific experimental setup.

**Technical Support:** The protocols provided are for reference purposes. Unsure if this reagent suits your experiment?

**Need Industrial/Bulk Grade?** [Request Custom Synthesis Quote](#)

## BenchChem

Our mission is to be the trusted global source of essential and advanced chemicals, empowering scientists and researchers to drive progress in science and industry.

### Contact

Address: 3281 E Guasti Rd

Ontario, CA 91761, United States

Phone: (601) 213-4426

Email: [info@benchchem.com](mailto:info@benchchem.com)

[Contact our Ph.D. Support Team for a compatibility check](#)