

The Role of Cdk7 Inhibition in Cell Cycle Regulation: A Technical Guide

Author: BenchChem Technical Support Team. **Date:** April 2026

Compound of Interest

Compound Name: Cdk7-IN-5
Cat. No.: B13918910

[Get Quote](#)

An In-depth Technical Guide for Researchers, Scientists, and Drug Development Professionals

Note to the Reader: The initial query specified "**Cdk7-IN-5**." Our research indicates that **Cdk7-IN-5** is an inhibitor of Cdc7 kinase, not Cdk7. Given the focus of the request on Cdk7's role in cell cycle regulation, this guide will focus on well-characterized and selective inhibitors of Cdk7, such as YKL-5-124 and THZ1, as representative compounds to elucidate the biological consequences of Cdk7 inhibition.

Executive Summary

Cyclin-dependent kinase 7 (Cdk7) is a pivotal enzyme that functions at the intersection of cell cycle control and transcriptional regulation. Its dual roles make it an attractive target for therapeutic intervention in oncology. This technical guide provides a comprehensive overview of the role of Cdk7 in cell cycle progression, with a focus on the effects of its inhibition. We present quantitative data on the activity of selective Cdk7 inhibitors, detailed protocols for key experimental assays, and visual representations of the underlying signaling pathways and experimental workflows.

The Dual Roles of Cdk7 in the Cell Cycle and Transcription

Cdk7 is a serine/threonine kinase that, in complex with Cyclin H and MAT1, forms the Cdk-activating kinase (CAK) complex. The CAK complex is responsible for the activating phosphorylation of several cell cycle-dependent kinases, including Cdk1, Cdk2, Cdk4, and Cdk6. This positions Cdk7 as a master regulator of cell cycle transitions.

Simultaneously, Cdk7 is a component of the general transcription factor TFIIH. In this capacity, it phosphorylates the C-terminal domain (CTD) of RNA polymerase II (Pol II), a critical step for the initiation and elongation phases of transcription. By inhibiting Cdk7, one can therefore induce both cell cycle arrest and transcriptional repression, making it a potent anti-proliferative strategy.

Quantitative Analysis of Cdk7 Inhibition

The development of selective Cdk7 inhibitors has enabled a detailed investigation of its functions. Below are tables summarizing the quantitative data for two prominent Cdk7 inhibitors, YKL-5-124 and THZ1.

Biochemical Potency of Cdk7 Inhibitors

Inhibitor	Target	IC50 (nM)	Notes
YKL-5-124	Cdk7	53.5	Potent and selective covalent inhibitor.[1][2]
Cdk7/Mat1/CycH	9.7	Higher potency in the complex.[1][3][4]	
Cdk2	1300	>100-fold selective over Cdk2.[2][4]	
Cdk9	3020	>100-fold selective over Cdk9.[2][4]	
Cdk12/13	Inactive	High selectivity against Cdk12/13.[1][2]	
THZ1	Cdk7	-	Covalent inhibitor, potency often measured by other means.
Cdk12/13	Equipotent	Also potently inhibits Cdk12/13, a key off-target.[2]	

Cellular Effects of Cdk7 Inhibition on Cell Cycle Distribution

Cell Line	Inhibitor	Concentration (nM)	Time (h)	% G1	% S	% G2/M	Reference
HAP1	YKL-5-124	125 - 2000	72	Increase	Decrease	Increase	[1]
HepG2	THZ1	200	24	-	Decrease	-	[5]
Hep3B	THZ1	200	24	-	Decrease	-	[5]
SK-Hep-1	THZ1	200	8	-	Decrease	-	[5]
B-ALL cells	THZ1	Varies	2-24	-	-	Arrested at G2/M	[6]
Cervical Cancer Cells	THZ1	Varies	-	-	-	Blockage at G2/M	[7]

Signaling Pathways and Experimental Workflows

Visualizing the complex biological processes and experimental designs is crucial for a comprehensive understanding. The following diagrams were generated using the Graphviz DOT language.

Cdk7 Signaling in Cell Cycle Progression

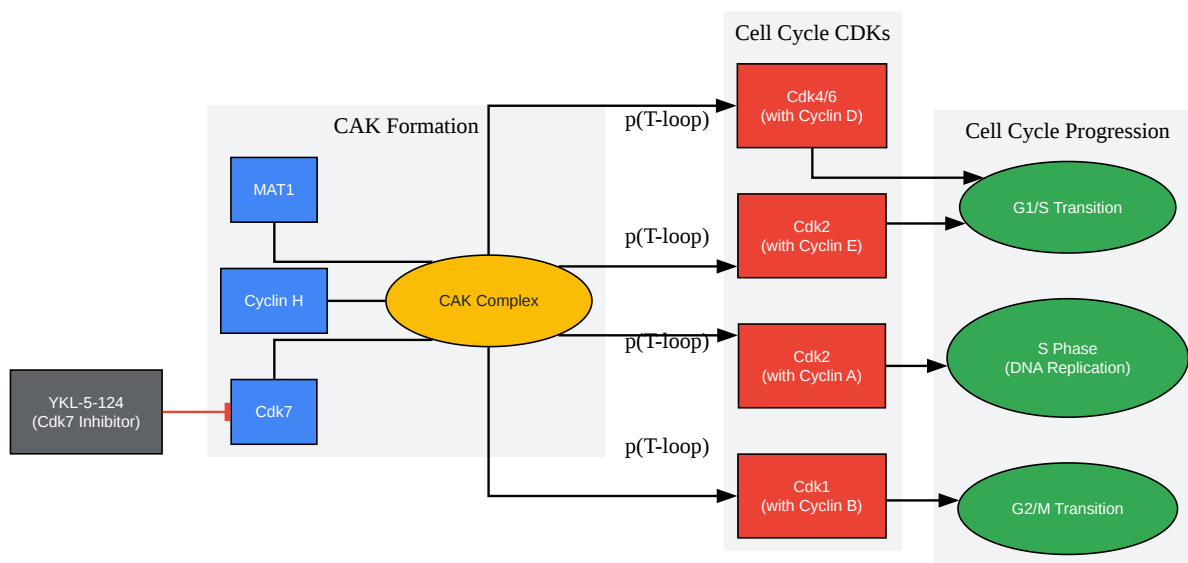

[Click to download full resolution via product page](#)

Caption: Cdk7's role as the Cdk-activating kinase (CAK) in the cell cycle.

Cdk7's Role in Transcriptional Regulation

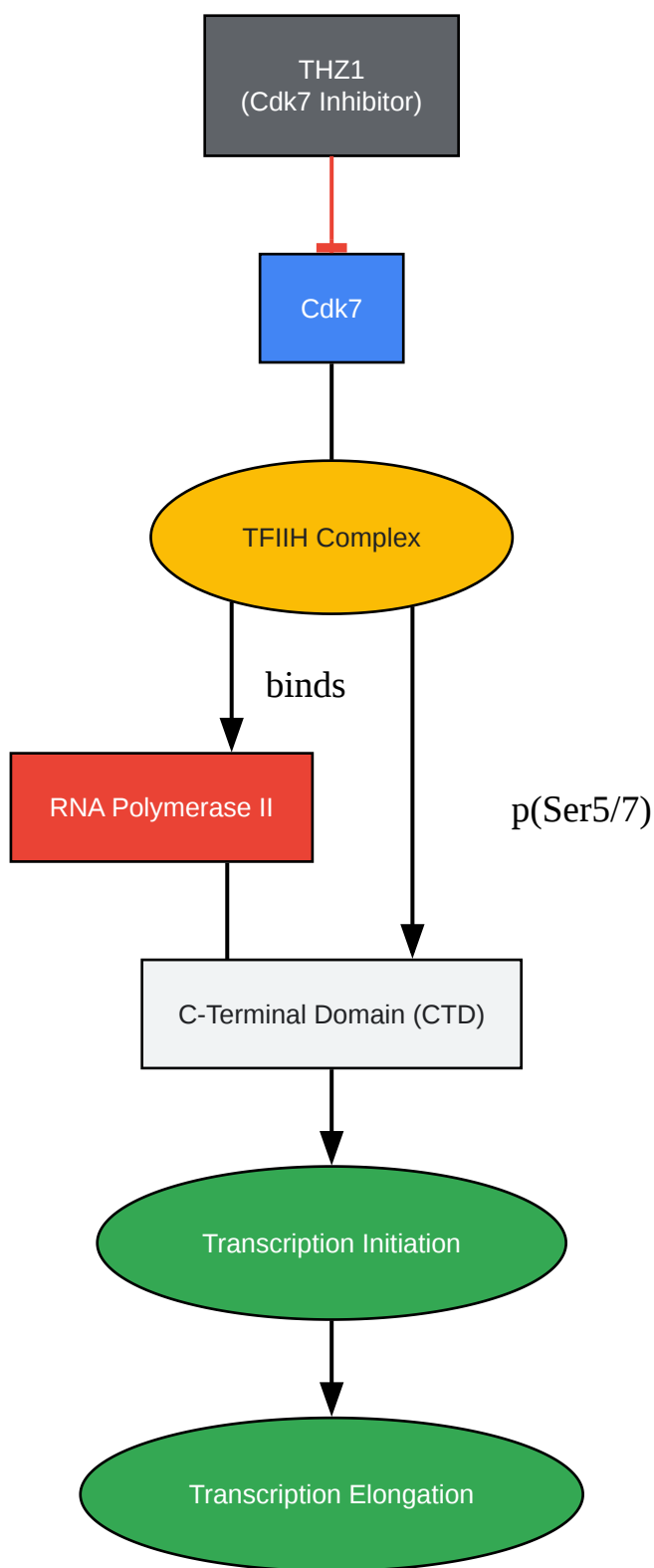

[Click to download full resolution via product page](#)

Caption: Cdk7's function within the TFIIH complex in transcription.

Experimental Workflow for Assessing Cdk7 Inhibitor Activity

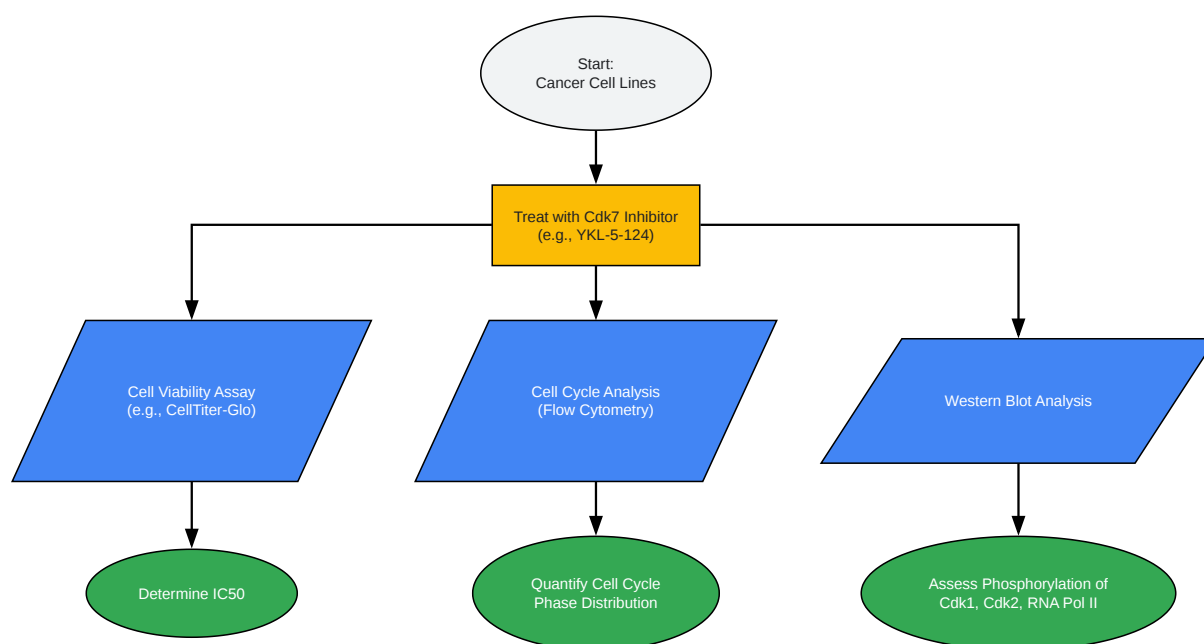

[Click to download full resolution via product page](#)

Caption: A typical workflow for evaluating the effects of a Cdk7 inhibitor.

Detailed Experimental Protocols

The following are detailed methodologies for key experiments cited in the study of Cdk7 inhibitors.

Cell Viability Assay (CellTiter-Glo®)

This protocol is adapted from the Promega CellTiter-Glo® Luminescent Cell Viability Assay.^[8]
^[9]^[10]^[11]

Objective: To determine the number of viable cells in culture based on the quantification of ATP.

Materials:

- Opaque-walled multiwell plates (96-well or 384-well)
- Mammalian cells in culture medium
- Cdk7 inhibitor (e.g., YKL-5-124)
- CellTiter-Glo® Reagent (Promega)
- Luminometer

Procedure:

- Cell Plating: Seed cells in opaque-walled multiwell plates at a density determined to be within the linear range of the assay. Include wells with medium only for background measurement.
- Compound Treatment: Add the Cdk7 inhibitor at various concentrations to the experimental wells. Include a vehicle control (e.g., DMSO). Incubate for the desired time period (e.g., 72 hours).
- Equilibration: Equilibrate the plate and its contents to room temperature for approximately 30 minutes.
- Reagent Addition: Add a volume of CellTiter-Glo® Reagent equal to the volume of cell culture medium in each well.
- Lysis and Signal Stabilization: Mix the contents for 2 minutes on an orbital shaker to induce cell lysis. Incubate at room temperature for 10 minutes to stabilize the luminescent signal.
- Measurement: Record the luminescence using a luminometer.

- **Data Analysis:** Subtract the background luminescence from all readings. Plot the cell viability against the inhibitor concentration to determine the IC50 value.

Cell Cycle Analysis by Propidium Iodide Staining and Flow Cytometry

This protocol is a generalized procedure based on standard methods.[\[12\]](#)[\[13\]](#)[\[14\]](#)[\[15\]](#)[\[16\]](#)

Objective: To analyze the distribution of cells in different phases of the cell cycle based on DNA content.

Materials:

- Cells treated with Cdk7 inhibitor
- Phosphate-Buffered Saline (PBS)
- 70% Ethanol (ice-cold)
- Propidium Iodide (PI) staining solution (containing RNase A)
- Flow cytometer

Procedure:

- **Cell Harvesting:** Harvest cells by trypsinization or scraping and wash with cold PBS.
- **Fixation:** Resuspend the cell pellet and add ice-cold 70% ethanol dropwise while gently vortexing to prevent clumping. Fix for at least 30 minutes on ice or at -20°C for longer storage.
- **Washing:** Centrifuge the fixed cells and wash twice with cold PBS.
- **Staining:** Resuspend the cell pellet in PI staining solution. Incubate for 15-30 minutes at room temperature in the dark.
- **Analysis:** Analyze the stained cells using a flow cytometer. Collect data from at least 10,000 single-cell events.

- Data Interpretation: Use cell cycle analysis software to generate a DNA content histogram and quantify the percentage of cells in the G0/G1, S, and G2/M phases.

Western Blotting for Phosphorylated Proteins

This protocol provides a general framework for detecting phosphorylated Cdk1 and Cdk2.[\[17\]](#)
[\[18\]](#)[\[19\]](#)[\[20\]](#)[\[21\]](#)

Objective: To assess the phosphorylation status of Cdk7 substrates, such as Cdk1 (p-Thr161) and Cdk2 (p-Thr160).

Materials:

- Cell lysates from inhibitor-treated and control cells
- SDS-PAGE gels
- Nitrocellulose or PVDF membranes
- Blocking buffer (e.g., 5% BSA or non-fat milk in TBST)
- Primary antibodies (e.g., anti-phospho-Cdk1 (Thr161), anti-phospho-Cdk2 (Thr160))
- HRP-conjugated secondary antibody
- Chemiluminescent substrate
- Imaging system

Procedure:

- Sample Preparation: Lyse cells and determine protein concentration. Prepare samples with Laemmli buffer and heat to denature.
- Electrophoresis: Separate proteins by SDS-PAGE.
- Transfer: Transfer the separated proteins to a nitrocellulose or PVDF membrane.

- **Blocking:** Block the membrane with blocking buffer for 1 hour at room temperature to prevent non-specific antibody binding.
- **Primary Antibody Incubation:** Incubate the membrane with the primary antibody (diluted in blocking buffer) overnight at 4°C with gentle agitation.
- **Washing:** Wash the membrane three times with TBST for 5-10 minutes each.
- **Secondary Antibody Incubation:** Incubate the membrane with the HRP-conjugated secondary antibody for 1 hour at room temperature.
- **Washing:** Repeat the washing step.
- **Detection:** Add the chemiluminescent substrate and capture the signal using an imaging system.
- **Analysis:** Quantify the band intensities and normalize to a loading control (e.g., β -actin or tubulin).

Conclusion

The inhibition of Cdk7 presents a compelling strategy for cancer therapy due to its dual impact on cell cycle progression and transcription. The use of selective inhibitors like YKL-5-124 has been instrumental in dissecting the specific roles of Cdk7, revealing a predominant cell cycle phenotype upon its inhibition. The methodologies and data presented in this guide offer a robust framework for researchers and drug developers to further explore the therapeutic potential of targeting Cdk7 in various malignancies.

Need Custom Synthesis?

BenchChem offers custom synthesis for rare earth carbides and specific isotopic labeling.

Email: info@benchchem.com or [Request Quote Online](#).

References

- 1. [medchemexpress.com](https://www.medchemexpress.com) [[medchemexpress.com](https://www.medchemexpress.com)]

- [2. Development of a selective CDK7 covalent inhibitor reveals predominant cell cycle phenotype - PMC \[pmc.ncbi.nlm.nih.gov\]](#)
- [3. YKL 5-124 | Transcriptional CDKs | Tocris Bioscience \[tocris.com\]](#)
- [4. selleckchem.com \[selleckchem.com\]](#)
- [5. researchgate.net \[researchgate.net\]](#)
- [6. CDK7 Inhibitor THZ1 Induces the Cell Apoptosis of B-Cell Acute Lymphocytic Leukemia by Perturbing Cellular Metabolism - PMC \[pmc.ncbi.nlm.nih.gov\]](#)
- [7. researchgate.net \[researchgate.net\]](#)
- [8. CellTiter-Glo® Luminescent Cell Viability Assay Protocol \[promega.com\]](#)
- [9. CellTiter-Glo® 3D Cell Viability Assay Protocol \[worldwide.promega.com\]](#)
- [10. promega.com \[promega.com\]](#)
- [11. ch.promega.com \[ch.promega.com\]](#)
- [12. Flow cytometry with PI staining | Abcam \[abcam.com\]](#)
- [13. Cell Cycle Analysis by DNA Content - Protocols - Flow Cytometry - UC San Diego Moores Cancer Center \[sites.medschool.ucsd.edu\]](#)
- [14. protocols.io \[protocols.io\]](#)
- [15. igbmc.fr \[igbmc.fr\]](#)
- [16. ucl.ac.uk \[ucl.ac.uk\]](#)
- [17. bosterbio.com \[bosterbio.com\]](#)
- [18. Western Blot Procedure | Cell Signaling Technology \[cellsignal.com\]](#)
- [19. Western Blotting Protocol \(Fluorescent\) | Cell Signaling Technology \[cellsignal.com\]](#)
- [20. Phospho-CDK2 \(Thr160\) Antibody \(#2561\) Datasheet With Images | Cell Signaling Technology \[cellsignal.com\]](#)
- [21. datasheets.scbt.com \[datasheets.scbt.com\]](#)
- To cite this document: BenchChem. [The Role of Cdk7 Inhibition in Cell Cycle Regulation: A Technical Guide]. BenchChem, [2026]. [Online PDF]. Available at: [\[https://www.benchchem.com/product/b13918910/docs#the-role-of-cdk7-inhibition-in-cell-cycle-regulation-a-technical-guide\]](https://www.benchchem.com/product/b13918910/docs#the-role-of-cdk7-inhibition-in-cell-cycle-regulation-a-technical-guide)

Disclaimer & Data Validity:

The information provided in this document is for Research Use Only (RUO) and is strictly not intended for diagnostic or therapeutic procedures. While BenchChem strives to provide accurate protocols, we make no warranties, express or implied, regarding the fitness of this product for every specific experimental setup.

Technical Support: The protocols provided are for reference purposes. Unsure if this reagent suits your experiment?

Need Industrial/Bulk Grade? [Request Custom Synthesis Quote](#)

BenchChem

Our mission is to be the trusted global source of essential and advanced chemicals, empowering scientists and researchers to drive progress in science and industry.

Contact

Address: 3281 E Guasti Rd
Ontario, CA 91761, United States
Phone: (601) 213-4426
Email: info@benchchem.com

[Contact our Ph.D. Support Team for a compatibility check](#)