

# Modifying experimental protocols for EGFR mutant-IN-2

**Author:** BenchChem Technical Support Team. **Date:** April 2026

## Compound of Interest

Compound Name: EGFR mutant-IN-2

Cat. No.: B15137557

[Get Quote](#)

## Technical Support Center: EGFR Mutant-IN-2

Welcome to the technical support center for **EGFR Mutant-IN-2**, a third-generation irreversible epidermal growth factor receptor (EGFR) inhibitor. This guide is intended for researchers, scientists, and drug development professionals to provide troubleshooting assistance and detailed experimental protocols. **EGFR Mutant-IN-2** is designed to selectively target common activating EGFR mutations (e.g., L858R, exon 19 deletions) and the T790M resistance mutation, while sparing wild-type (WT) EGFR.

## Frequently Asked Questions (FAQs)

Q1: What is the mechanism of action of **EGFR Mutant-IN-2**?

A1: **EGFR Mutant-IN-2** is an irreversible inhibitor that specifically targets the ATP-binding site of mutant EGFR. It forms a covalent bond with a cysteine residue (Cys797) within the kinase domain. This covalent binding leads to potent and sustained inhibition of EGFR signaling pathways, primarily the RAS-RAF-MEK-ERK (MAPK) and PI3K-AKT-mTOR pathways, which are crucial for cell proliferation and survival. Its design allows it to be particularly effective against the T790M mutation, which often confers resistance to first and second-generation EGFR inhibitors by increasing ATP affinity.[1][2]

Q2: Which cell lines are recommended for testing the efficacy of **EGFR Mutant-IN-2**?

A2: The choice of cell line is critical for evaluating the activity of **EGFR Mutant-IN-2**. We recommend using cell lines with well-characterized EGFR mutation statuses. For example, NCI-H1975 cells harbor both the L858R activating mutation and the T790M resistance mutation, making them an excellent model for assessing the inhibitor's efficacy against this common resistance mechanism.[3] PC-9 cells, which have an exon 19 deletion, are sensitive to EGFR inhibitors and can be used to determine potency against activating mutations.[4] For assessing selectivity, a cell line with wild-type EGFR, such as A431 (which overexpresses WT EGFR), can be used.[4]

Q3: What are the expected off-target effects of **EGFR Mutant-IN-2**?

A3: While **EGFR Mutant-IN-2** is designed for high selectivity towards mutant EGFR, some off-target effects on wild-type EGFR can occur, especially at higher concentrations. This can lead to side effects such as skin rash and diarrhea, which are common for EGFR inhibitors. Kinase profiling assays are recommended to determine the broader selectivity profile against other kinases like HER2 and HER4.

## Troubleshooting Guide

Problem 1: Inconsistent IC50 values in cell viability assays.

- Possible Cause: High variability in experimental setup.
  - Solution: Ensure consistent cell seeding density, as uneven plating is a major source of variability. Use a homogenous cell suspension and calibrate pipettes regularly. To mitigate "edge effects" in 96-well plates, avoid using the outer wells or fill them with sterile PBS or media.
- Possible Cause: Serum interference.
  - Solution: Serum contains growth factors that can compete with the inhibitor. Consider reducing the serum concentration (e.g., to 2-5%) or using serum-free media during the drug treatment period if the cells can tolerate it.
- Possible Cause: Cell line integrity.

- Solution: Use low-passage, authenticated cell lines. Genetic drift in cell lines can alter their response to drugs.

Problem 2: No inhibition of EGFR phosphorylation observed in Western Blot.

- Possible Cause: Incorrect antibody or blotting procedure.
  - Solution: Use a phospho-specific antibody for the activated form of EGFR (e.g., p-EGFR Tyr1068). Ensure the Western blot protocol is optimized for large membrane proteins like EGFR (175 kDa), which may require longer transfer times or lower percentage acrylamide gels.
- Possible Cause: Suboptimal lysis buffer.
  - Solution: EGFR is a transmembrane protein, so a strong lysis buffer such as RIPA buffer is recommended to ensure complete protein extraction.
- Possible Cause: High EGF concentration in the media.
  - Solution: In experiments designed to test the inhibitory effect of the compound, ensure that the cells are not stimulated with high concentrations of EGF, which could overcome the inhibitory effect.

Problem 3: Low or no activity in a kinase assay.

- Possible Cause: Improper assay setup.
  - Solution: Ensure that the ATP concentration in the assay is appropriate. Since EGFR inhibitors are often ATP-competitive, the apparent potency can be affected by the ATP concentration. Use an ATP concentration that is close to the  $K_m$  of the enzyme for ATP.
- Possible Cause: Inactive enzyme.
  - Solution: Verify the activity of the recombinant EGFR enzyme using a known potent inhibitor as a positive control. Ensure proper storage and handling of the enzyme.

## Data Presentation

Table 1: In Vitro Kinase Inhibition Profile of a Representative 3rd Generation EGFR Inhibitor

Target Kinase	IC50 (nM)
EGFR (Wild-Type)	75.8
EGFR (L858R)	2.1
EGFR (T790M)	18.3
EGFR (L858R/T790M)	12.5
HER2	95.2
HER4	>1000

Data is illustrative for a typical 3rd generation EGFR inhibitor.

Table 2: Cellular Proliferation Inhibition (GI50) of a Representative 3rd Generation EGFR Inhibitor

Cell Line	EGFR Status	GI50 (nM)
A431	Wild-Type Overexpression	30.2
NCI-H1975	L858R/T790M	45.7
PC-9	del E746-A750	18.9
SW620	KRAS Mutant (EGFR WT)	>10,000

Data is illustrative for a typical 3rd generation EGFR inhibitor.

## Experimental Protocols

### Protocol 1: Cell Viability (MTT) Assay

- Cell Seeding:
  - Harvest and count cells, ensuring viability is >95%.

- Seed cells in a 96-well plate at a density of 5,000 cells/well in 100  $\mu$ L of complete medium.
- Incubate overnight at 37°C, 5% CO<sub>2</sub> to allow for cell attachment.
- Drug Treatment:
  - Prepare serial dilutions of **EGFR Mutant-IN-2** in culture medium. The final DMSO concentration should be consistent across all wells (typically  $\leq 0.1\%$ ).
  - Remove the old medium and add 100  $\mu$ L of the drug-containing medium. Include untreated and vehicle control wells.
  - Incubate for 72 hours.
- MTT Addition and Incubation:
  - Add 20  $\mu$ L of MTT solution (5 mg/mL in PBS) to each well and incubate for 4 hours at 37°C.
- Formazan Solubilization and Measurement:
  - Remove the medium and add 100  $\mu$ L of DMSO to dissolve the formazan crystals.
  - Measure the absorbance at 570 nm using a microplate reader.
- Data Analysis:
  - Calculate the percentage of cell growth inhibition relative to the vehicle control and determine the GI<sub>50</sub> values.

## Protocol 2: Western Blot for EGFR Phosphorylation

- Cell Treatment and Lysis:
  - Seed cells in a 6-well plate and grow to 70-80% confluency.
  - Treat cells with **EGFR Mutant-IN-2** at various concentrations for the desired time (e.g., 2-4 hours).

- Wash cells with ice-cold PBS and lyse with 150  $\mu$ L of ice-cold RIPA buffer containing protease and phosphatase inhibitors.
- Protein Quantification:
  - Determine the protein concentration of the lysates using a BCA assay.
  - Normalize the protein concentration for all samples.
- SDS-PAGE and Transfer:
  - Load 20-30  $\mu$ g of protein per lane onto an 8% SDS-PAGE gel.
  - Run the gel to separate proteins by size.
  - Transfer the proteins to a PVDF membrane.
- Immunoblotting:
  - Block the membrane with 5% BSA in TBST for 1 hour at room temperature.
  - Incubate the membrane with primary antibodies (e.g., anti-p-EGFR, anti-total-EGFR, and a loading control like beta-actin) overnight at 4°C.
  - Wash the membrane three times with TBST.
  - Incubate with the appropriate HRP-conjugated secondary antibody for 1 hour at room temperature.
  - Wash the membrane three times with TBST.
- Detection:
  - Apply ECL substrate and capture the chemiluminescent signal using an imaging system.

### **Protocol 3: In Vitro Kinase Assay (ADP-Glo™)**

- Reagent Preparation:

- Prepare the kinase reaction buffer (e.g., 40mM Tris, pH 7.5; 20mM MgCl<sub>2</sub>; 0.1mg/ml BSA; 2mM MnCl<sub>2</sub>; 50μM DTT).
- Prepare serial dilutions of **EGFR Mutant-IN-2**.
- Kinase Reaction:
  - In a 384-well plate, add the recombinant EGFR enzyme, the substrate (e.g., a poly(Glu, Tyr) peptide), and the diluted inhibitor or vehicle control.
  - Incubate for 30 minutes at room temperature to allow for covalent bond formation.
  - Initiate the kinase reaction by adding ATP.
  - Incubate for 1 hour at room temperature.
- Signal Detection:
  - Stop the reaction and measure the amount of ADP produced using the ADP-Glo™ Kinase Assay Kit according to the manufacturer's instructions.
  - Luminescence is measured using a plate reader.
- Data Analysis:
  - Calculate the IC<sub>50</sub> values by fitting the dose-response data to a four-parameter logistic equation.

## Visualizations

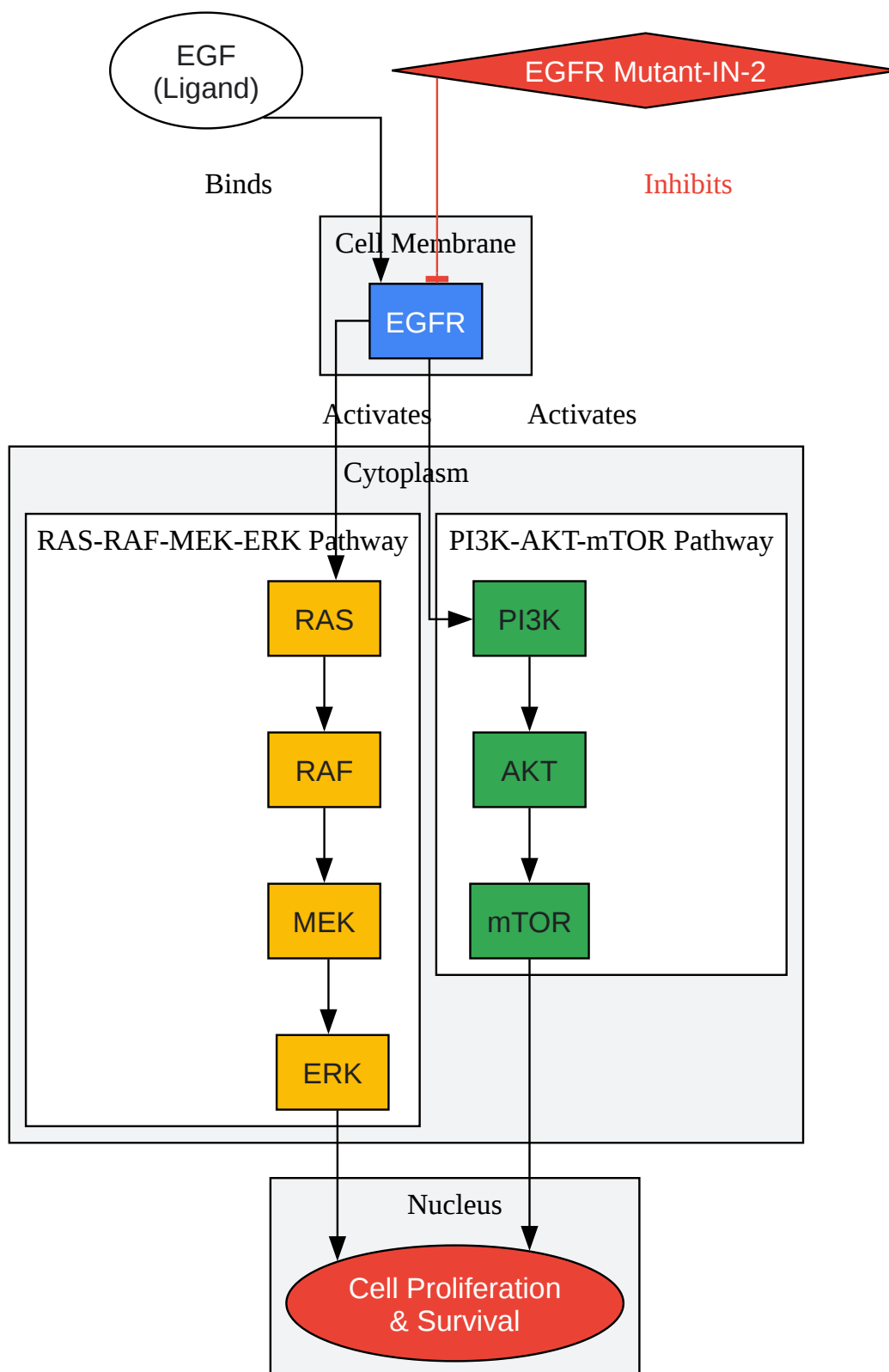

[Click to download full resolution via product page](#)

Caption: EGFR signaling cascade and the inhibitory action of **EGFR Mutant-IN-2**.

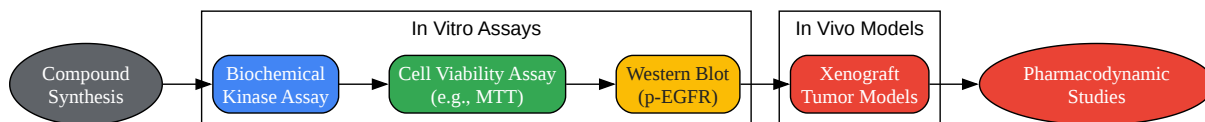

[Click to download full resolution via product page](#)

Caption: General experimental workflow for EGFR inhibitor development.

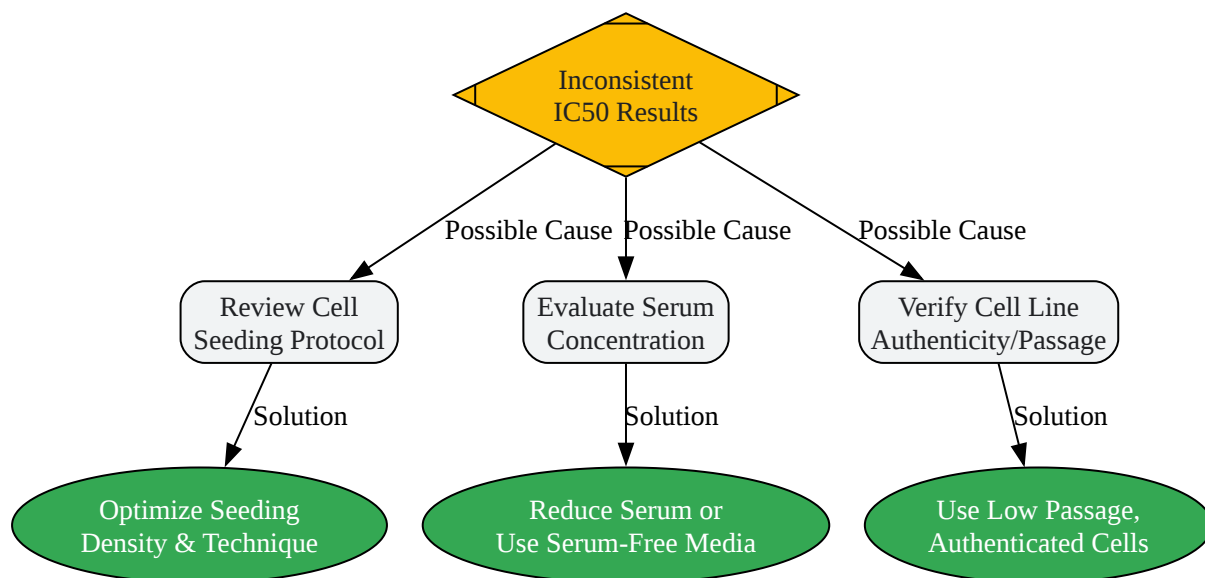

[Click to download full resolution via product page](#)

**Need Custom Synthesis?**

BenchChem offers custom synthesis for rare earth carbides and specific isotopic labeling.

Email: [info@benchchem.com](mailto:info@benchchem.com) or [Request Quote Online](#).

**References**

- [1. pnas.org \[pnas.org\]](https://pubs.pnas.org)
- [2. De Novo T790M Mutation in an L858R Epidermal Growth Factor Receptor Mutant-Associated Lung Adenocarcinoma - PMC \[pmc.ncbi.nlm.nih.gov\]](#)
- [3. Differential protein stability of EGFR mutants determines responsiveness to tyrosine kinase inhibitors - PMC \[pmc.ncbi.nlm.nih.gov\]](#)
- [4. benchchem.com \[benchchem.com\]](https://www.benchchem.com)
- To cite this document: BenchChem. [Modifying experimental protocols for EGFR mutant-IN-2]. BenchChem, [2026]. [Online PDF]. Available at: [\[https://www.benchchem.com/product/b15137557/docs#modifying-experimental-protocols-for-egfr-mutant-in-2\]](https://www.benchchem.com/product/b15137557/docs#modifying-experimental-protocols-for-egfr-mutant-in-2)

---

### Disclaimer & Data Validity:

The information provided in this document is for Research Use Only (RUO) and is strictly not intended for diagnostic or therapeutic procedures. While BenchChem strives to provide accurate protocols, we make no warranties, express or implied, regarding the fitness of this product for every specific experimental setup.

**Technical Support:** The protocols provided are for reference purposes. Unsure if this reagent suits your experiment?

**Need Industrial/Bulk Grade?** [Request Custom Synthesis Quote](#)

## BenchChem

Our mission is to be the trusted global source of essential and advanced chemicals, empowering scientists and researchers to drive progress in science and industry.

### Contact

Address: 3281 E Guasti Rd  
Ontario, CA 91761, United States  
Phone: (601) 213-4426  
Email: [info@benchchem.com](mailto:info@benchchem.com)

Contact our Ph.D. Support Team for a compatibility check