

Application Notes and Protocols for M-Se₃ in Thermoelectric Devices

Author: BenchChem Technical Support Team. **Date:** April 2026

Compound of Interest

Compound Name: *m*-Se₃
Cat. No.: B15137670

[Get Quote](#)

For Researchers, Scientists, and Drug Development Professionals

This document provides detailed application notes and protocols for the utilization of metal selenide (**M-Se₃**) compounds in thermoelectric devices. It covers the synthesis of various **M-Se₃** materials, fabrication of thermoelectric modules, and characterization of their performance.

Introduction to M-Se₃ Thermoelectric Materials

Thermoelectric materials offer a promising avenue for clean energy generation by directly converting waste heat into useful electrical energy and for solid-state cooling applications. The efficiency of a thermoelectric material is quantified by the dimensionless figure of merit, ZT, defined as:

$$ZT = (S^2\sigma / \kappa) * T$$

where:

- S is the Seebeck coefficient ($\mu\text{V/K}$)
- σ is the electrical conductivity (S/m)

- κ is the thermal conductivity (W/(m·K))
- T is the absolute temperature (K)

A high ZT value is indicative of a more efficient thermoelectric material. The term $S^2\sigma$ is known as the power factor, representing the material's capacity to generate electrical power from a temperature gradient. The thermal conductivity (κ) represents a loss mechanism, and therefore, a low value is desirable.

Metal selenides, particularly those of copper, silver, and tin, have emerged as promising candidates for thermoelectric applications due to their favorable electronic and thermal transport properties.

Quantitative Data Summary

The following tables summarize the thermoelectric properties of various metal selenide compounds.

Material	Synthesis Method	Temperature (K)	Seebeck Coefficient (S) ($\mu\text{V/K}$)	Electrical Conductivity (σ) (S/m)	Thermal Conductivity (κ) ($\text{W/(m}\cdot\text{K)}$)	Power Factor ($\mu\text{W/(m}\cdot\text{K}^2)$)	Figure of Merit (ZT)	Reference
β - Cu_2Se	Ball Milling & Hot Pressing	973	-	-	0.4 - 0.5	-	~1.6	[1]
$\text{Cu}_2\text{-xSe}$ (sintered)	Wet Chemical & Sintering	423	~125	$\sim 8 \times 10^4$	~1.0	~1250	~0.46	[2]
Ag_2Se	Room Temperature Aqueous Synthesis	380	-	-	-	-	~0.76	[3]
$\text{Ag}_2\text{Se/Bi}_2\text{S}_3$ (1.0 wt%)	Solution Blending & Hot Pressing	370	-	-	-	-	0.96	[3]
SnSe (single crystal)	Bridgman Method	923	-	-	~0.23	-	2.6	[4]
CsAg_5S_3	First-principles	700	-	-	< 0.27	2500	2.5	[5]

(predict es
ed) calculati
on

Experimental Protocols

Synthesis of M-Se₃ Materials

This protocol describes a wet chemical method for the synthesis of Cu₃Se₂ nanoparticles.

Materials:

- Selenium (Se) powder
- Sodium sulfite (Na₂SO₃)
- Copper (II) sulfate pentahydrate (CuSO₄·5H₂O)
- Deionized (DI) water
- Ethanol

Procedure:

- In a 100 mL beaker, mix 0.32 g of Se powder and 1.26 g of Na₂SO₃ in 50 mL of DI water.
- Stir the mixture for 1 hour at 80°C to dissolve the selenium.
- Allow the solution to cool to room temperature.
- Filter the mixture to remove any undissolved solids.
- In a separate 100 mL beaker, dissolve 2 g of CuSO₄·5H₂O in 50 mL of DI water.
- Slowly pour the selenium-containing supernatant into the CuSO₄ solution while stirring.
- Continue stirring the mixture at room temperature for 2 hours.
- Collect the resulting precipitate by centrifugation or filtration.

- Wash the precipitate thoroughly with DI water and ethanol to remove any unreacted precursors.
- Dry the final Cu_3Se_2 powder at 60°C in a vacuum oven.[2]

This protocol details a facile, room-temperature, solventless method for synthesizing Ag_2Se .

Materials:

- Silver (Ag) powder (3N, 200 mesh)
- Selenium (Se) powder (5N, 200 mesh)

Procedure:

- Weigh stoichiometric amounts of Ag and Se powders (2:1 molar ratio). For example, weigh 2.158 g of Ag and 0.790 g of Se.
- Combine the powders in a mortar.
- Gently grind the powders together using a pestle for approximately 30 minutes. The reaction is initiated by the mechanical contact and proceeds spontaneously.
- The color of the powder mixture will change, indicating the formation of Ag_2Se .
- The resulting Ag_2Se powder is ready for consolidation.[6]

Thermoelectric Device Fabrication

This protocol describes the consolidation of synthesized **M-Se3** powders into dense pellets for thermoelectric property measurements and device fabrication.

Materials:

- Synthesized **M-Se3** powder
- Graphite die and punches

Procedure:

- Load the **M-Se3** powder into a graphite die.
- Place the die into a hot-press furnace.
- Apply a uniaxial pressure of approximately 50 MPa.
- Heat the sample to the desired sintering temperature (e.g., 400-700°C for copper selenides) under an inert atmosphere (e.g., Argon) or vacuum.[1]
- Hold the temperature and pressure for a specified duration (e.g., 5-30 minutes) to allow for densification.
- Cool the sample down to room temperature before releasing the pressure.
- Eject the densified pellet from the die. The pellet is now ready for cutting and characterization.

Characterization of Thermoelectric Properties

The Seebeck coefficient and electrical conductivity are typically measured simultaneously using a commercial system (e.g., ULVAC ZEM-3) or a custom-built setup. The four-probe method is commonly employed.

Procedure:

- Cut a bar-shaped sample from the hot-pressed pellet with typical dimensions of 2mm x 2mm x 12mm.
- Mount the sample in the measurement apparatus.
- Four probes are brought into contact with the sample. Two outer probes are used to pass a constant DC current through the sample, and two inner probes, acting as a thermocouple, measure the voltage drop and the temperature difference.
- The measurement is performed in a high-vacuum or inert gas atmosphere to prevent oxidation at high temperatures.
- A temperature gradient (ΔT) is established across the sample by a small heater at one end.

- The thermoelectric voltage (ΔV) generated by the Seebeck effect is measured between the two inner probes.
- The Seebeck coefficient (S) is calculated as $S = -\Delta V / \Delta T$.
- The electrical resistance (R) is measured by passing a known current (I) through the outer probes and measuring the voltage drop (V) across the inner probes ($R = V/I$).
- The electrical conductivity (σ) is then calculated using the sample dimensions (A = cross-sectional area, L = distance between inner probes) as $\sigma = L / (R * A)$.^[7]

The laser flash analysis (LFA) is a widely used technique to determine the thermal diffusivity (α) of a material. The thermal conductivity (κ) can then be calculated if the specific heat capacity (C_p) and density (ρ) are known.

Procedure:

- Prepare a thin, disc-shaped sample (typically 1-3 mm thick and 6-12.7 mm in diameter) from the hot-pressed pellet. The surfaces should be parallel and flat.
- Coat the sample with a thin layer of graphite to ensure good absorption of the laser pulse and high emissivity for the infrared detector.
- Place the sample in the LFA instrument.
- The front face of the sample is irradiated with a short, high-intensity laser pulse.
- An infrared detector on the rear face of the sample records the temperature rise as a function of time.
- The thermal diffusivity (α) is calculated from the time it takes for the rear face temperature to reach half of its maximum rise ($t_{1/2}$), using the formula: $\alpha = 0.1388 * (d^2 / t_{1/2})$, where d is the sample thickness.
- The specific heat capacity (C_p) is measured separately, often using a differential scanning calorimeter (DSC).
- The density (ρ) of the sample is determined using the Archimedes method.

- Finally, the thermal conductivity (κ) is calculated using the equation: $\kappa = \alpha * \rho * C_p$.^{[8][9]}

Visualizations

Conceptual Pathway to High Thermoelectric Performance

The following diagram illustrates the key material properties that contribute to a high thermoelectric figure of merit (ZT).

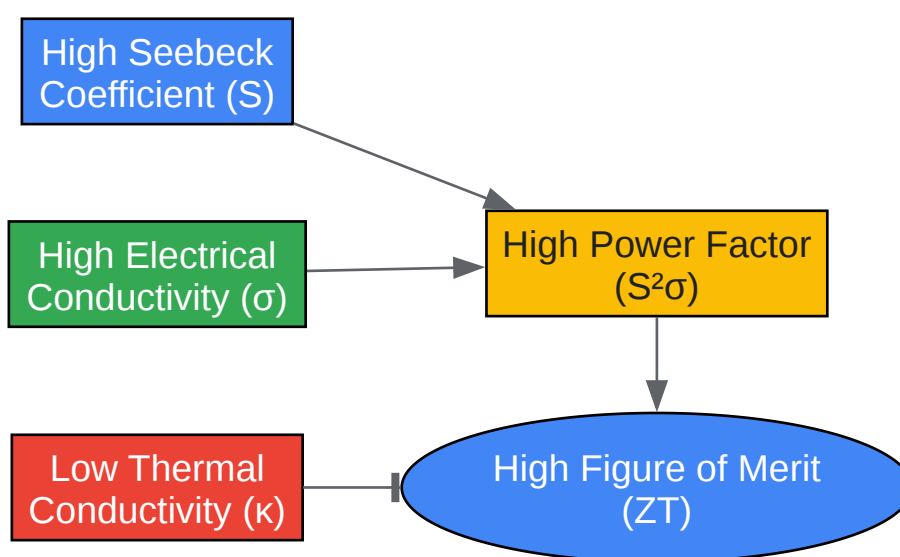

[Click to download full resolution via product page](#)

Caption: Relationship between key material properties and thermoelectric performance.

Experimental Workflow for M-Se₃ Thermoelectric Material Development

This diagram outlines the typical experimental workflow from material synthesis to performance evaluation.

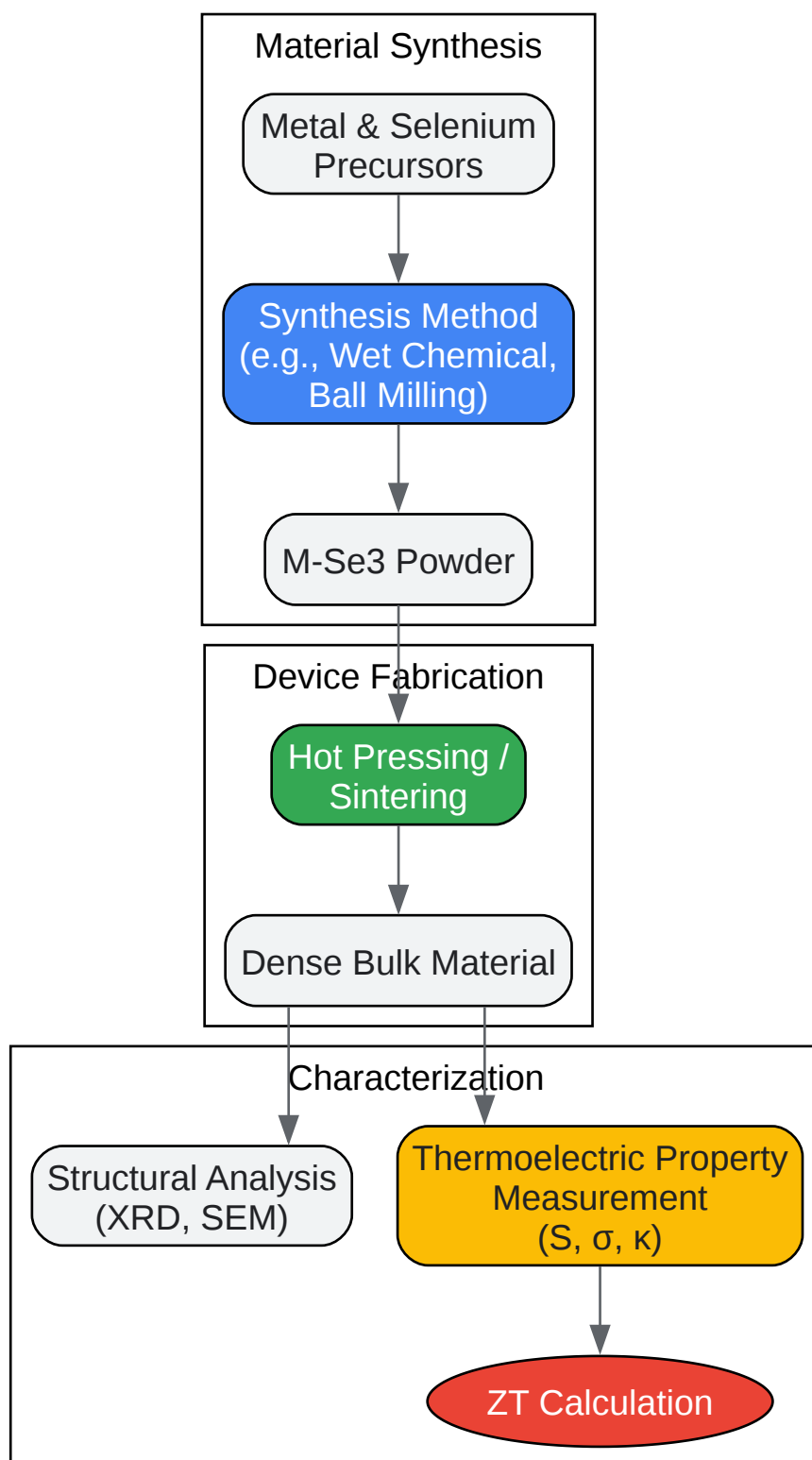

[Click to download full resolution via product page](#)

Caption: Experimental workflow for **M-Se₃** thermoelectric material development.

Phonon Scattering Mechanisms for Low Thermal Conductivity

This diagram illustrates how various scattering mechanisms contribute to reducing lattice thermal conductivity, a key factor for high ZT.

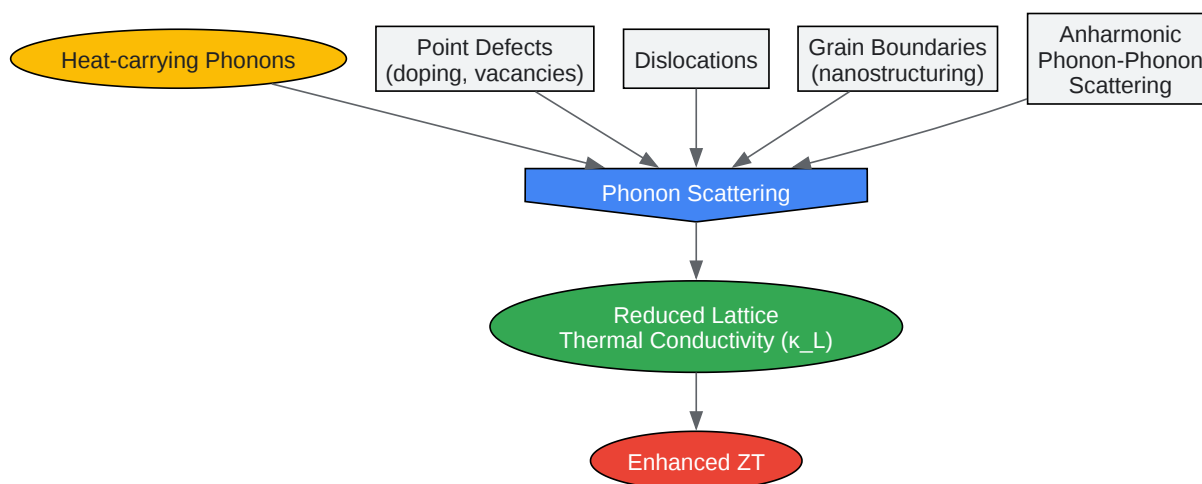

[Click to download full resolution via product page](#)

Need Custom Synthesis?

BenchChem offers custom synthesis for rare earth carbides and specific isotopic labeling.

Email: info@benchchem.com or [Request Quote Online](#).

References

- 1. analyzing-testing.netzsch.com [analyzing-testing.netzsch.com]
- 2. ira.lib.polyu.edu.hk [ira.lib.polyu.edu.hk]

- [3. \[1707.02737\] Phonon-Driven Electron Scattering and Magnetothermoelectric Effect in Two-Dimensional Tin Selenide \[arxiv.org\]](#)
- [4. Laser Flash Analysis for bulk thermoelectric materials: relation between thermal conductivity and electrical properties \[iris.cnr.it\]](#)
- [5. pubs.aip.org \[pubs.aip.org\]](#)
- [6. \[2411.10605\] Effects of Four-Phonon Scattering and Wave-like Phonon Tunneling Effects on Thermoelectric Properties of Mg₂GeSe₄ using Machine Learning \[arxiv.org\]](#)
- [7. analyzing-testing.netzsch.com \[analyzing-testing.netzsch.com\]](#)
- [8. rsc.org \[rsc.org\]](#)
- [9. tsapps.nist.gov \[tsapps.nist.gov\]](#)
- To cite this document: BenchChem. [Application Notes and Protocols for M-Se₃ in Thermoelectric Devices]. BenchChem, [2026]. [Online PDF]. Available at: [\[https://www.benchchem.com/product/b15137670/docs#application-notes-and-protocols-for-m-se3-in-thermoelectric-devices\]](https://www.benchchem.com/product/b15137670/docs#application-notes-and-protocols-for-m-se3-in-thermoelectric-devices)

Disclaimer & Data Validity:

The information provided in this document is for Research Use Only (RUO) and is strictly not intended for diagnostic or therapeutic procedures. While BenchChem strives to provide accurate protocols, we make no warranties, express or implied, regarding the fitness of this product for every specific experimental setup.

Technical Support: The protocols provided are for reference purposes. Unsure if this reagent suits your experiment?

Need Industrial/Bulk Grade? [Request Custom Synthesis Quote](#)

BenchChem

Our mission is to be the trusted global source of essential and advanced chemicals, empowering scientists and researchers to drive progress in science and industry.

Contact

Address: 3281 E Guasti Rd
Ontario, CA 91761, United States
Phone: (601) 213-4426
Email: info@benchchem.com

Contact our Ph.D. Support Team for a compatibility check