

# Application Notes and Protocols for D-156 in Cell Culture Experiments

**Author:** BenchChem Technical Support Team. **Date:** April 2026

## Compound of Interest

Compound Name: DHC-156  
Cat. No.: B15137150

[Get Quote](#)

For Researchers, Scientists, and Drug Development Professionals

These application notes provide detailed protocols and recommended concentrations for using **DHC-156**, a potent and selective downmodulator of the transcription factor brachyury, in a variety of cell culture experiments. The information is intended to guide researchers in utilizing **DHC-156** to investigate the role of brachyury in cancer biology and to assess its therapeutic potential.

## Introduction to DHC-156

**DHC-156** is a small molecule that post-translationally downmodulates brachyury, a key driver of chordoma and a protein implicated in the progression of several other cancers, including those of the breast, colon, lung, and prostate. It has been shown to induce an irreversible impairment of chordoma tumor cell growth.[1] Brachyury is associated with the epithelial-to-mesenchymal transition (EMT), a process that endows cancer cells with migratory and invasive properties.

Chemical Properties:

Property	Value
Molecular Weight	492.47 g/mol
Formula	C <sub>24</sub> H <sub>24</sub> F <sub>4</sub> N <sub>4</sub> O <sub>3</sub>
Solubility	Soluble in DMSO up to 100 mM
Storage	Store at -20°C

## Recommended DHC-156 Concentrations for In Vitro Assays

The optimal concentration of **DHC-156** will vary depending on the cell line and the specific experimental endpoint. The following table summarizes recommended starting concentrations based on available data, primarily in chordoma cell lines, and provides guidance for other brachyury-expressing cancer cell lines.

Cell Line Type	Assay	Recommended Starting Concentration	Notes
Chordoma (e.g., CH-22, UM-Chor1)	Brachyury Downmodulation (Western Blot, Immunofluorescence)	10 $\mu$ M	Effective downmodulation observed.[1][2]
Cell Viability / Cytotoxicity	5 - 10 $\mu$ M	Significant reduction in cell viability reported in this range. [1]	
Apoptosis Assay	5 - 10 $\mu$ M	Expected to induce apoptosis following brachyury downregulation.	
Cell Cycle Analysis	5 - 10 $\mu$ M	May induce cell cycle arrest.	
Brachyury-Expressing Non-Chordoma Cancers (e.g., Breast, Colorectal, Lung, Prostate)	Brachyury Downmodulation (Western Blot, Immunofluorescence)	5 - 20 $\mu$ M	Start with a dose-response experiment to determine optimal concentration.
Cell Viability / Cytotoxicity (IC50 determination)	1 - 50 $\mu$ M	A broad range is recommended for initial screening to determine the half-maximal inhibitory concentration (IC50).	
Apoptosis Assay	IC50 concentration	Use the predetermined IC50 as a starting point for apoptosis induction.	

---

Cell Cycle Analysis	IC50 concentration	Analyze cell cycle distribution at the IC50 to assess for arrest.
EMT Marker Analysis	5 - 20 $\mu$ M	Assess changes in markers like E-cadherin and Vimentin.

---

## Experimental Protocols

### Preparation of DHC-156 Stock Solution

- Reconstitution: Prepare a 10 mM stock solution of **DHC-156** by dissolving it in DMSO. For example, to make 1 ml of a 10 mM stock, dissolve 4.92 mg of **DHC-156** in 1 ml of DMSO.
- Storage: Aliquot the stock solution into smaller volumes to avoid repeated freeze-thaw cycles and store at  $-20^{\circ}\text{C}$ .

### Cell Culture and Seeding

- Chordoma Cell Lines (CH-22, U-CH1): Culture CH-22 cells in RPMI-1640 medium supplemented with 10% FBS.[3] For U-CH1 cells, use a 4:1 mixture of IMDM and RPMI-1640 supplemented with 10% FBS.[4]
- Other Cancer Cell Lines: Culture cells in their recommended growth medium.
- Seeding Density: Seed cells in appropriate culture vessels (e.g., 96-well plates for viability assays, 6-well plates for protein extraction) to reach 50-70% confluency at the time of treatment.

### Cell Viability (MTT) Assay

- Seed cells in a 96-well plate and allow them to attach overnight.
- Treat cells with a serial dilution of **DHC-156** (e.g., 0.1, 1, 5, 10, 25, 50  $\mu$ M) for 24, 48, or 72 hours. Include a DMSO-treated vehicle control.

- Add MTT reagent to each well and incubate for 2-4 hours at 37°C.
- Add solubilization solution (e.g., DMSO or a designated solubilizing agent) to dissolve the formazan crystals.
- Measure the absorbance at the appropriate wavelength (typically 570 nm).
- Calculate cell viability as a percentage of the vehicle control and determine the IC50 value.

## Western Blotting for Brachyury and EMT Markers

- Seed cells in 6-well plates and treat with the desired concentration of **DHC-156** for 24-48 hours.
- Lyse the cells in RIPA buffer supplemented with protease and phosphatase inhibitors.
- Determine protein concentration using a BCA or Bradford assay.
- Separate 20-30 µg of protein per lane on an SDS-PAGE gel.
- Transfer the proteins to a PVDF membrane.
- Block the membrane with 5% non-fat milk or BSA in TBST for 1 hour at room temperature.
- Incubate the membrane with primary antibodies against brachyury, E-cadherin, Vimentin, and a loading control (e.g., β-actin or GAPDH) overnight at 4°C.
- Wash the membrane with TBST and incubate with the appropriate HRP-conjugated secondary antibody for 1 hour at room temperature.
- Visualize the protein bands using an enhanced chemiluminescence (ECL) detection system.

## Apoptosis Assay (Annexin V/Propidium Iodide Staining)

- Seed cells in a 6-well plate and treat with **DHC-156** at the IC50 concentration for 24-48 hours.
- Harvest both adherent and floating cells and wash them with cold PBS.

- Resuspend the cells in 1X Annexin V binding buffer.
- Add FITC-conjugated Annexin V and Propidium Iodide (PI) to the cell suspension.
- Incubate in the dark for 15 minutes at room temperature.
- Analyze the cells by flow cytometry within one hour.
  - Live cells: Annexin V-negative and PI-negative.
  - Early apoptotic cells: Annexin V-positive and PI-negative.
  - Late apoptotic/necrotic cells: Annexin V-positive and PI-positive.

## Cell Cycle Analysis (Propidium Iodide Staining)

- Seed cells in a 6-well plate and treat with **DHC-156** at the IC50 concentration for 24 hours.
- Harvest the cells and wash with PBS.
- Fix the cells in ice-cold 70% ethanol while gently vortexing. Incubate at -20°C for at least 2 hours.
- Wash the fixed cells with PBS to remove the ethanol.
- Resuspend the cell pellet in a staining solution containing Propidium Iodide (PI) and RNase A.
- Incubate in the dark for 30 minutes at room temperature.
- Analyze the DNA content by flow cytometry to determine the percentage of cells in the G0/G1, S, and G2/M phases of the cell cycle.

## Signaling Pathways and Visualizations

**DHC-156** directly targets and downmodulates the transcription factor brachyury. The downstream effects of this action can vary depending on the cellular context.

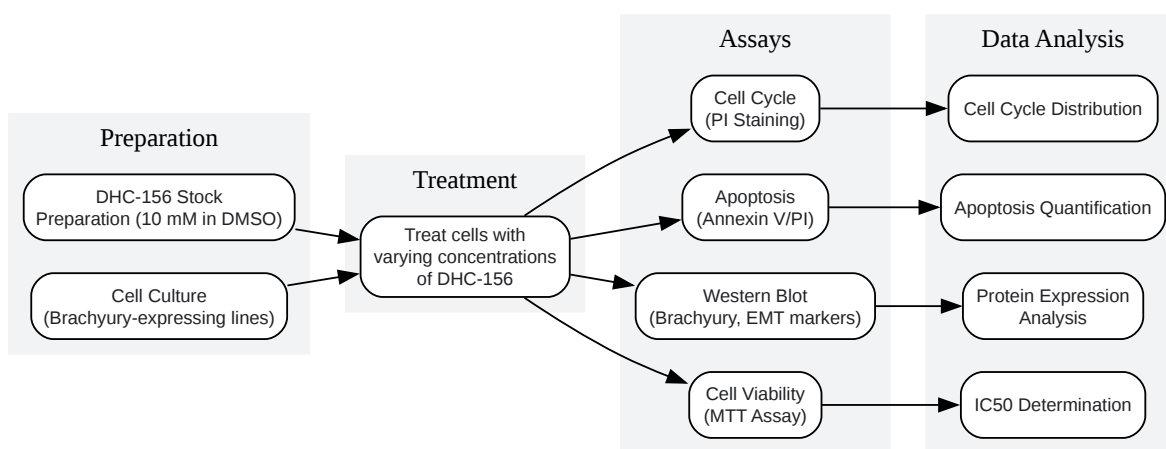
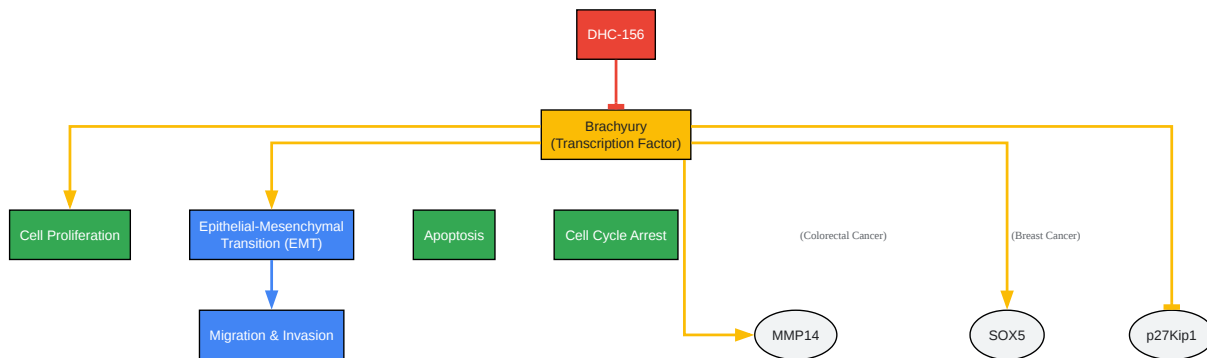

[Click to download full resolution via product page](#)

**Need Custom Synthesis?**

BenchChem offers custom synthesis for rare earth carbides and specific isotopic labeling.

Email: [info@benchchem.com](mailto:info@benchchem.com) or [Request Quote Online](#).

## References

- [1. Cytotoxicity of synthetic derivatives against breast cancer and multi-drug resistant breast cancer cell lines: a literature-based perspective study - PMC \[pmc.ncbi.nlm.nih.gov\]](#)
- [2. Automation, live-cell imaging, and endpoint cell viability for prostate cancer drug screens | PLOS One \[journals.plos.org\]](#)
- [3. HDAC inhibitors induce epithelial-mesenchymal transition in colon carcinoma cells - PubMed \[pubmed.ncbi.nlm.nih.gov\]](#)
- [4. Depletion of HDAC6 enhances cisplatin-induced DNA damage and apoptosis in non-small cell lung cancer cells - PubMed \[pubmed.ncbi.nlm.nih.gov\]](#)
- To cite this document: BenchChem. [Application Notes and Protocols for D-156 in Cell Culture Experiments]. BenchChem, [2026]. [Online PDF]. Available at: [\[https://www.benchchem.com/product/b15137150/docs#application-notes-and-protocols-for-d-156-in-cell-culture-experiments\]](https://www.benchchem.com/product/b15137150/docs#application-notes-and-protocols-for-d-156-in-cell-culture-experiments)

---

### Disclaimer & Data Validity:

The information provided in this document is for Research Use Only (RUO) and is strictly not intended for diagnostic or therapeutic procedures. While BenchChem strives to provide accurate protocols, we make no warranties, express or implied, regarding the fitness of this product for every specific experimental setup.

**Technical Support:** The protocols provided are for reference purposes. Unsure if this reagent suits your experiment?

**Need Industrial/Bulk Grade?** [Request Custom Synthesis Quote](#)

## BenchChem

Our mission is to be the trusted global source of essential and advanced chemicals, empowering scientists and researchers to drive progress in science and industry.

### Contact

Address: 3281 E Guasti Rd  
Ontario, CA 91761, United States  
Phone: (601) 213-4426  
Email: [info@benchchem.com](mailto:info@benchchem.com)

Contact our Ph.D. Support Team for a compatibility check