

A Comparative Guide to Alexa Fluor 647 Antibody Conjugation Kits

Author: BenchChem Technical Support Team. **Date:** December 2025

Compound of Interest

Compound Name: AF647-NHS ester triTEA

Cat. No.: B15137587

[Get Quote](#)

For researchers, scientists, and drug development professionals, the selection of an appropriate fluorescent labeling kit is critical for generating high-quality antibody conjugates for use in a variety of applications, from basic research to clinical assays. Alexa Fluor 647 (AF647), a bright and photostable far-red fluorescent dye, is a popular choice for antibody conjugation. This guide provides an objective comparison of commercially available AF647 antibody labeling kits, focusing on their performance, protocols, and key features to aid in selecting the optimal kit for your research needs.

Performance Comparison of AF647 Labeling Kits

The ideal AF647 antibody conjugation kit should offer high labeling efficiency, optimal degree of labeling (DOL), and maximal recovery of a functional antibody. While direct head-to-head third-party comparisons are limited, this section summarizes the key performance indicators based on manufacturer's data and available literature.

Feature	Thermo Fisher Scientific (Invitrogen™) Kits	Abcam (Lightning-Link®) Kits	AAT Bioquest (ReadiLink™) Kits
Kit Names	Alexa Fluor™ 647 Protein Labeling Kit, Alexa Fluor™ 647 Microscale Protein Labeling Kit, SAIVI™ Alexa Fluor™ 647 Antibody/Protein Labeling Kit	Alexa Fluor® 647 Conjugation Kit (Fast) - Lightning-Link®	ReadiLink™ Rapid AF647 Antibody Labeling Kit
Conjugation Time	~90 minutes (Protein Labeling Kit), <30 minutes (Microscale Kit)	< 20 minutes	Minimal hands-on time[1]
Hands-on Time	~15-30 minutes	~30 seconds	Minimal[1]
Antibody Recovery	>85% (with purification)[2]	100% (no purification step)[3]	Not specified, no purification needed[1]
Purification Required	Yes (spin column or resin based)[4][5]	No[3]	No[1]
Optimal DOL	Typically 3-7 moles of dye per mole of IgG[2][4]	Not specified by manufacturer, but designed for optimal performance	Not specified
Control over DOL	Yes, with SAIVI™ kits using a DOL modulating reagent[4]	Less direct control	Not specified
Starting Material	Purified antibody, free of amine-containing buffers[5]	Purified antibody, compatible with some common buffers	Purified antibody
Kit Components	Reactive dye, purification resin,	Lyophilized mixture of dye and reagents,	Vials of AF647 dye and reaction

buffers

modifier, quencher

components

Experimental Protocols

Detailed methodologies are crucial for reproducible experimental outcomes. Below are representative protocols for antibody conjugation and the determination of the degree of labeling.

General Antibody Conjugation Workflow

The following diagram illustrates a typical workflow for antibody conjugation using a labeling kit. The specific steps and incubation times may vary depending on the chosen kit.

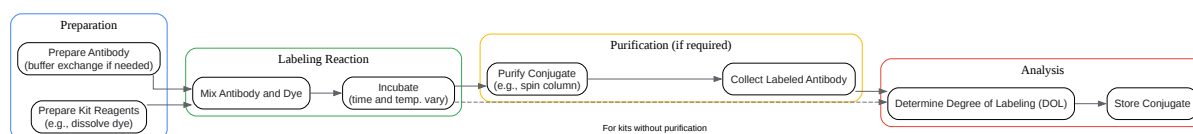

[Click to download full resolution via product page](#)

Caption: A generalized workflow for antibody conjugation to AF647.

Protocol 1: Antibody Conjugation using a Purification-Based Kit (e.g., Thermo Fisher Scientific)

- Antibody Preparation: Ensure the antibody is in an amine-free buffer (e.g., PBS) at a concentration of 1-2 mg/mL.^{[2][5]}
- Reaction Setup: Add the provided reaction buffer to the antibody solution.
- Labeling: Add the antibody solution to the vial of reactive AF647 dye.

- Incubation: Incubate the mixture for the time specified in the kit protocol (e.g., 60-90 minutes) at room temperature with gentle stirring.[2]
- Purification: Separate the labeled antibody from the unreacted dye using the provided spin column or purification resin.
- Elution: Elute the purified antibody conjugate.

Protocol 2: Rapid Antibody Conjugation without Purification (e.g., Abcam Lightning-Link®)

- Antibody Preparation: The antibody should be at a concentration of 0.5-2 mg/mL in a compatible buffer (pH 6.5-8.5).
- Modifier Addition: Add the modifier reagent to the antibody solution.[3]
- Labeling: Pipette the antibody-modifier mixture directly into the lyophilized vial of AF647.[3]
- Incubation: Incubate for 15 minutes at room temperature in the dark.[3]
- Quenching: Add the quencher reagent to stop the reaction. The conjugate is ready to use after 5 minutes.[3]

Protocol 3: Determination of Degree of Labeling (DOL)

The DOL is the average number of dye molecules conjugated to a single antibody molecule. It can be determined spectrophotometrically.

- Spectrophotometer Measurement: Measure the absorbance of the purified antibody conjugate at 280 nm (A₂₈₀) and 650 nm (A₆₅₀).[2][4][5]
- Calculate Protein Concentration:
 - Protein Concentration (M) = $[A_{280} - (A_{650} \times 0.03)] / \epsilon_{\text{protein}}$
 - Where $\epsilon_{\text{protein}}$ is the molar extinction coefficient of the antibody at 280 nm (for IgG, ~210,000 M⁻¹cm⁻¹) and 0.03 is a correction factor for the dye's absorbance at 280 nm.[5]

- Calculate Dye Concentration:
 - Dye Concentration (M) = $A_{650} / \epsilon_{\text{dye}}$
 - Where ϵ_{dye} is the molar extinction coefficient of AF647 at 650 nm ($\sim 239,000 \text{ M}^{-1}\text{cm}^{-1}$).
[2][4]
- Calculate DOL:
 - $\text{DOL} = \text{Dye Concentration (M)} / \text{Protein Concentration (M)}$

An optimal DOL is crucial as a high DOL can lead to fluorescence quenching and reduced antibody binding affinity, while a low DOL results in a weaker signal.[4] For many applications, a DOL of 3-7 is considered optimal for IgG antibodies.[2][4]

Impact of Conjugation Chemistry on Antibody Function

The most common antibody labeling kits, including those for AF647, utilize amine-reactive chemistry, targeting primary amines (e.g., lysine residues) on the antibody.[6][7] This method is robust and straightforward. However, as lysine residues can be present in the antigen-binding site (Fab region), this conjugation strategy can potentially impact antibody affinity.[8]

The following diagram illustrates the principle of amine-reactive labeling.

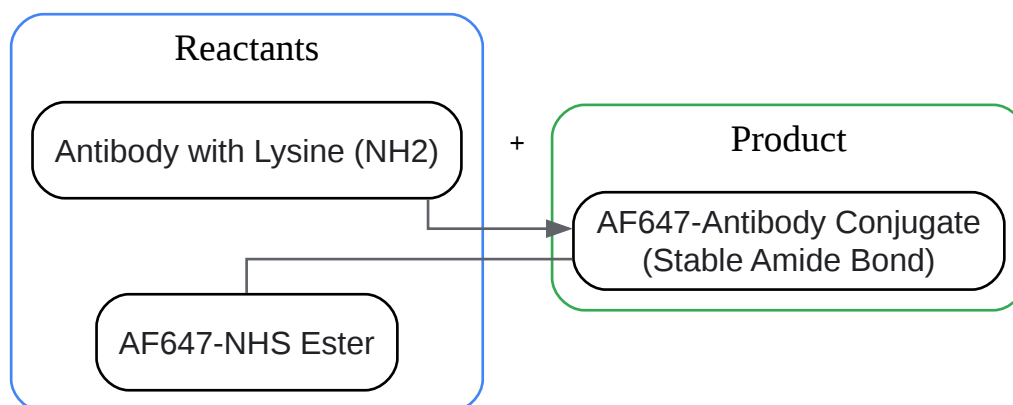

[Click to download full resolution via product page](#)

Caption: Amine-reactive labeling of an antibody with an NHS-ester functionalized dye.

For applications highly sensitive to antibody binding affinity, alternative conjugation strategies targeting sulfhydryl groups or carbohydrate moieties may be considered, although these are less common in all-in-one commercial kits.

Conclusion

The choice of an AF647 antibody labeling kit depends on the specific priorities of the researcher. For speed and convenience, with 100% antibody recovery, rapid kits such as Abcam's Lightning-Link® are an excellent choice, as they eliminate the need for a purification step.[3] For applications where precise control over the degree of labeling is paramount, and for larger scale conjugations, traditional kits with a purification step, like those from Thermo Fisher Scientific, offer more flexibility and control.[4] It is recommended to carefully consider the antibody's starting buffer composition and the desired final conjugate characteristics when selecting a kit. For critical applications, a preliminary small-scale labeling experiment to optimize the protocol for a specific antibody is advisable.

Need Custom Synthesis?

BenchChem offers custom synthesis for rare earth carbides and specific isotopic labeling.

Email: info@benchchem.com or [Request Quote Online](#).

References

- 1. file.elabscience.com [file.elabscience.com]
- 2. tools.thermofisher.com [tools.thermofisher.com]
- 3. abcam.com [abcam.com]
- 4. assets.thermofisher.cn [assets.thermofisher.cn]
- 5. assets.fishersci.com [assets.fishersci.com]
- 6. researchgate.net [researchgate.net]
- 7. Comparative study of the three different fluorophore antibody conjugation strategies - PubMed [pubmed.ncbi.nlm.nih.gov]

- 8. Fluorescent labeled antibodies - balancing functionality and degree of labeling - PMC [pmc.ncbi.nlm.nih.gov]
- To cite this document: BenchChem. [A Comparative Guide to Alexa Fluor 647 Antibody Conjugation Kits]. BenchChem, [2025]. [Online PDF]. Available at: [https://www.benchchem.com/product/b15137587#comparing-labeling-kits-for-af647-conjugation]

Disclaimer & Data Validity:

The information provided in this document is for Research Use Only (RUO) and is strictly not intended for diagnostic or therapeutic procedures. While BenchChem strives to provide accurate protocols, we make no warranties, express or implied, regarding the fitness of this product for every specific experimental setup.

Technical Support: The protocols provided are for reference purposes. Unsure if this reagent suits your experiment? [[Contact our Ph.D. Support Team for a compatibility check](#)]

Need Industrial/Bulk Grade? [Request Custom Synthesis Quote](#)

BenchChem

Our mission is to be the trusted global source of essential and advanced chemicals, empowering scientists and researchers to drive progress in science and industry.

Contact

Address: 3281 E Guasti Rd

Ontario, CA 91761, United States

Phone: (601) 213-4426

Email: info@benchchem.com