

Validating Target Engagement of Novel c-Met Inhibitors: A Comparative Guide

Author: BenchChem Technical Support Team. **Date:** April 2026

Compound of Interest

Compound Name: *c-Met-IN-19*

Cat. No.: *B15136428*

[Get Quote](#)

For Researchers, Scientists, and Drug Development Professionals

The receptor tyrosine kinase c-Met is a critical signaling node in cell proliferation, motility, and invasion, making it a prime target in cancer therapy. Validating that a novel inhibitor, such as the hypothetical "**c-Met-IN-19**," effectively engages its intended target within a cellular context is a crucial step in preclinical drug development. This guide provides a framework for validating the target engagement of new c-Met inhibitors by comparing them to established alternatives. It outlines key experiments, presents data in a clear, comparative format, and provides detailed protocols.

Comparative Analysis of c-Met Inhibitors

Effective validation involves comparing the performance of a novel inhibitor against well-characterized compounds. This table provides a template for summarizing key quantitative data. Researchers should aim to generate this data for their novel compound ("**c-Met-IN-19**") and compare it against known inhibitors.

Parameter	c-Met-IN-19 (Hypothetical Data)	Crizotinib (Reference)	Capmatinib (Reference)	Savolitinib (Reference)
Biochemical IC50 (c-Met)	[Insert experimental value, e.g., 5 nM]	4 nM	0.8 nM	5 nM
Cellular IC50 (Phospho-c-Met)	[Insert experimental value, e.g., 20 nM]	12 nM	1.3 nM	7 nM
Cell Proliferation IC50 (e.g., MKN- 45)	[Insert experimental value, e.g., 50 nM]	8 nM	3 nM	10 nM
Selectivity (Kinase Panel)	[Describe, e.g., Highly selective for c-Met]	Also inhibits ALK, ROS1	Highly selective for c-Met	Highly selective for c-Met

Experimental Protocols

Detailed methodologies are essential for reproducible and comparable results. Below are protocols for key experiments in validating c-Met target engagement.

Western Blot for Phospho-c-Met Inhibition

This assay directly measures the ability of an inhibitor to block c-Met autophosphorylation in cells.

Protocol:

- **Cell Culture:** Plate a c-Met-dependent cancer cell line (e.g., MKN-45, EBC-1) in 6-well plates and grow to 70-80% confluency.
- **Serum Starvation:** Replace the growth medium with a serum-free medium and incubate for 12-24 hours.

- Inhibitor Treatment: Treat the cells with a dose range of **c-Met-IN-19** and reference inhibitors for 2 hours.
- HGF Stimulation: Stimulate the cells with hepatocyte growth factor (HGF) at 50 ng/mL for 15 minutes to induce c-Met phosphorylation.
- Cell Lysis: Wash the cells with cold PBS and lyse them in RIPA buffer supplemented with protease and phosphatase inhibitors.
- Protein Quantification: Determine the protein concentration of each lysate using a BCA assay.
- Western Blotting:
 - Separate equal amounts of protein (20-30 µg) on an SDS-PAGE gel and transfer to a PVDF membrane.
 - Block the membrane with 5% BSA in TBST for 1 hour.
 - Incubate the membrane overnight at 4°C with primary antibodies against phospho-c-Met (Tyr1234/1235) and total c-Met.
 - Wash the membrane and incubate with HRP-conjugated secondary antibodies for 1 hour at room temperature.
 - Develop the blot using an ECL substrate and image the chemiluminescence.
- Densitometry Analysis: Quantify the band intensities and normalize the phospho-c-Met signal to the total c-Met signal.

Cellular Thermal Shift Assay (CETSA)

CETSA is a powerful method to confirm direct binding of an inhibitor to its target protein in a cellular environment.

Protocol:

- Cell Culture and Treatment: Culture a relevant cell line and treat with **c-Met-IN-19** or a vehicle control for a specified time.
- Harvesting: Harvest the cells by scraping and resuspend them in PBS with protease inhibitors.
- Heating: Aliquot the cell suspension and heat the samples to a range of temperatures (e.g., 40-70°C) for 3 minutes, followed by cooling for 3 minutes at room temperature.
- Lysis: Lyse the cells by three freeze-thaw cycles.
- Centrifugation: Separate the soluble and aggregated protein fractions by centrifugation at 20,000 x g for 20 minutes at 4°C.
- Western Blotting: Collect the supernatant (soluble fraction) and analyze the levels of soluble c-Met by Western blotting as described above. A successful target engagement will result in a thermal stabilization of c-Met at higher temperatures in the inhibitor-treated samples compared to the vehicle control.

Visualizing Pathways and Workflows

Understanding the underlying biological pathways and experimental designs is facilitated by clear diagrams.

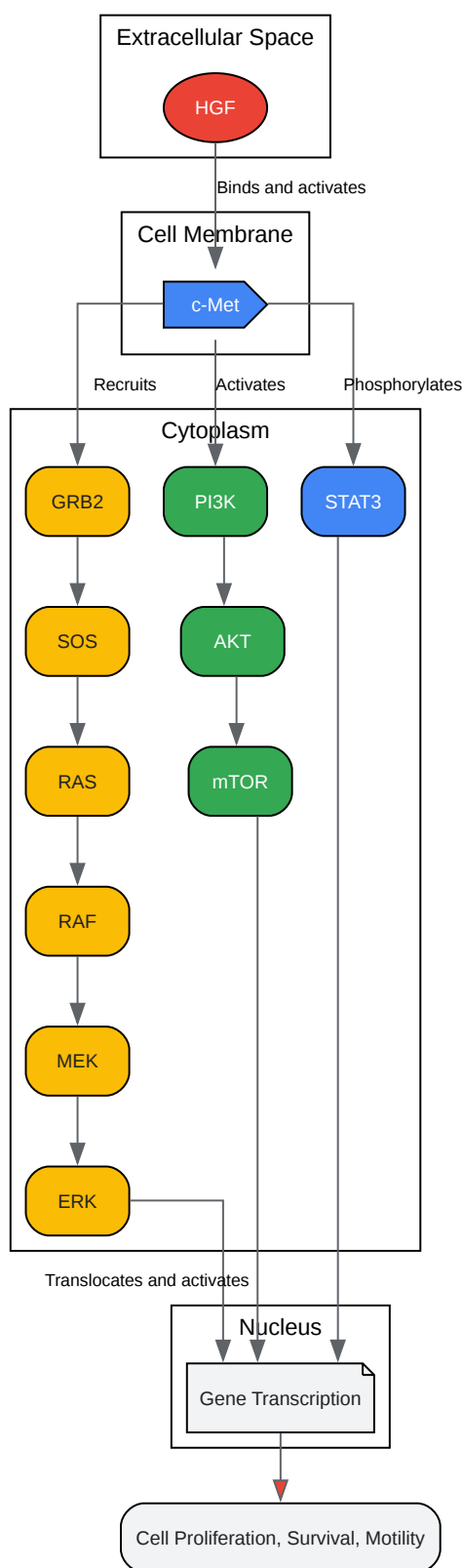

[Click to download full resolution via product page](#)

Caption: The c-Met signaling pathway, initiated by HGF binding.

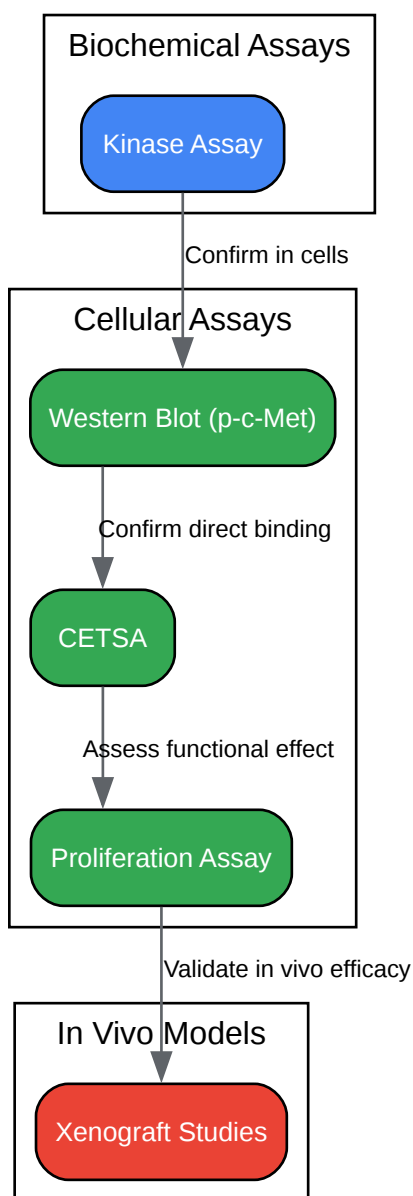

[Click to download full resolution via product page](#)

Caption: Experimental workflow for c-Met inhibitor validation.

- To cite this document: BenchChem. [Validating Target Engagement of Novel c-Met Inhibitors: A Comparative Guide]. BenchChem, [2026]. [Online PDF]. Available at: [<https://www.benchchem.com/product/b15136428/docs#validating-target-engagement-of-novel-c-met-inhibitors-a-comparative-guide>]

Disclaimer & Data Validity:

The information provided in this document is for Research Use Only (RUO) and is strictly not intended for diagnostic or therapeutic procedures. While BenchChem strives to provide accurate protocols, we make no warranties, express or implied, regarding the fitness of this product for every specific experimental setup.

Technical Support: The protocols provided are for reference purposes. Unsure if this reagent suits your experiment?

Need Industrial/Bulk Grade? [Request Custom Synthesis Quote](#)

BenchChem

Our mission is to be the trusted global source of essential and advanced chemicals, empowering scientists and researchers to drive progress in science and industry.

Contact

Address: 3281 E Guasti Rd
Ontario, CA 91761, United States
Phone: (601) 213-4426
Email: info@benchchem.com

[Contact our Ph.D. Support Team for a compatibility check](#)