

Application Notes and Protocols for Entrectinib-d4 in Drug-Drug Interaction Studies

Author: BenchChem Technical Support Team. **Date:** April 2026

Compound of Interest

Compound Name: *Entrectinib-d4*

Cat. No.: *B15136519*

[Get Quote](#)

For Researchers, Scientists, and Drug Development Professionals

These application notes provide a comprehensive overview of the use of **Entrectinib-d4** as an internal standard in drug-drug interaction (DDI) studies for entrectinib. Detailed protocols for in vitro and clinical DDI studies are outlined to guide researchers in accurately assessing the interaction potential of entrectinib with other therapeutic agents.

Introduction to Entrectinib and Drug-Drug Interactions

Entrectinib is a potent and selective tyrosine kinase inhibitor that targets TRKA/B/C, ROS1, and ALK fusion proteins, which are key drivers in various solid tumors.[1][2][3] The metabolism of entrectinib is primarily mediated by the cytochrome P450 3A4 (CYP3A4) enzyme.[2][4] This makes entrectinib susceptible to interactions with drugs that inhibit or induce CYP3A4, potentially leading to altered plasma concentrations and an increased risk of adverse events or reduced efficacy. Understanding these potential interactions is critical for the safe and effective use of entrectinib in clinical practice.

Entrectinib-d4, a deuterated form of entrectinib, serves as an ideal internal standard for quantitative bioanalysis using liquid chromatography-tandem mass spectrometry (LC-MS/MS). Its near-identical physicochemical properties to entrectinib ensure that it behaves similarly during sample preparation and analysis, allowing for accurate correction of variability and matrix effects.

Quantitative Data Summary

The following tables summarize the key quantitative data related to the drug-drug interaction potential of entrectinib.

Table 1: In Vitro Inhibition and Substrate Data for Entrectinib

Parameter	Value	System/Assay	Reference
CYP3A4/5 Inhibition (IC50)	2 μ M	Human Biomaterials	
P-glycoprotein (P-gp) Inhibition (IC50)	1.33 μ M	Human Biomaterials	
P-gp Substrate Status	Poor Substrate	In vitro P-gp Assay	
BCRP Substrate Status	Not a Substrate	In vitro Assays	

Table 2: Clinical Pharmacokinetic Drug-Drug Interactions with Entrectinib

Co-administered Drug (Perpetrator)	Effect on Entrectinib (Victim)	Reference
Itraconazole (Strong CYP3A4 Inhibitor)	C _{max} : \uparrow 73% AUC: \uparrow 504%	
Rifampin (Strong CYP3A4 Inducer)	C _{max} : \downarrow 56% AUC: \downarrow 77%	

Table 3: Entrectinib as a Perpetrator Drug

Co-administered Drug (Victim)	Effect of Entrectinib on Victim Drug	Reference
Midazolam (Sensitive CYP3A4 Substrate)	Single Dose Entrectinib: -	
	AUC: No effect - Cmax: ↓ 34%	
	Multiple Dose Entrectinib: -	
	AUC: ↑ 50% - Cmax: ↓ 21%	
Digoxin (P-gp Substrate)	Single Dose Entrectinib: -	
	AUC: ↑ 18% - Cmax: ↑ 28%	

Signaling Pathway of Entrectinib

Entrectinib inhibits the signaling pathways of TRK, ROS1, and ALK, which, when activated by fusion events, lead to downstream signaling that promotes cell proliferation and survival.

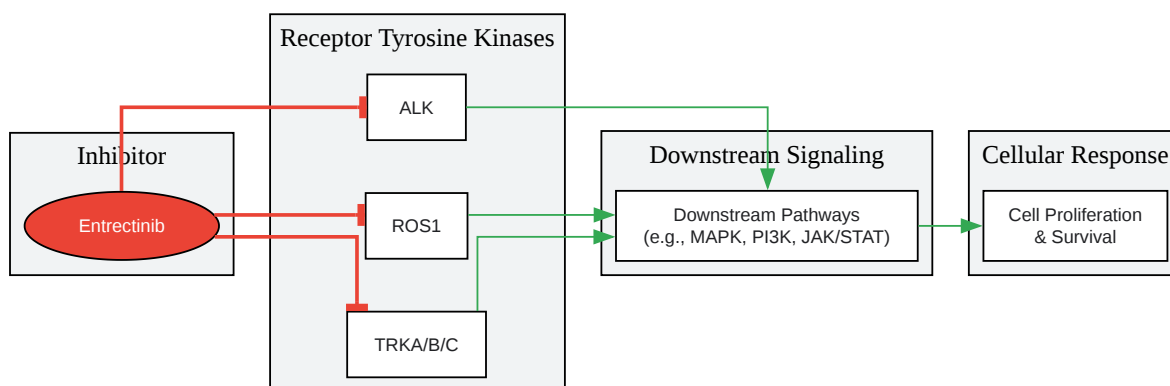

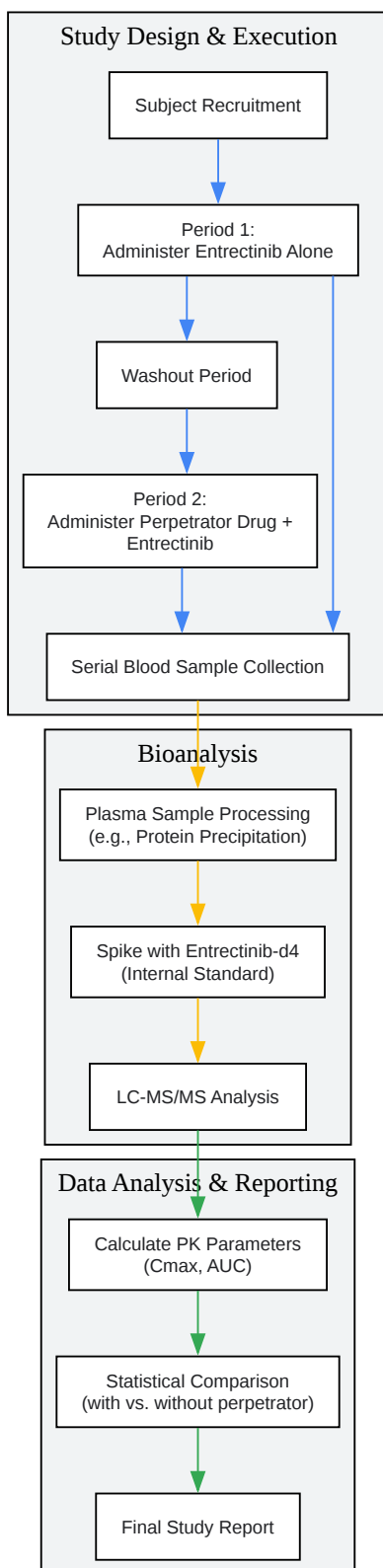

[Click to download full resolution via product page](#)

Need Custom Synthesis?

BenchChem offers custom synthesis for rare earth carbides and specific isotopic labeling.

Email: info@benchchem.com or [Request Quote Online](#).

References

- [1. cancercareontario.ca](http://cancercareontario.ca) [cancercareontario.ca]
- [2. go.drugbank.com](http://go.drugbank.com) [go.drugbank.com]
- [3. Entrectinib: A Review in NTRK+ Solid Tumours and ROS1+ NSCLC - PMC](#) [pmc.ncbi.nlm.nih.gov]
- [4. In vitro and clinical investigations to determine the drug-drug interaction potential of entrectinib, a small molecule inhibitor of neurotrophic tyrosine receptor kinase \(NTRK\) - PubMed](#) [pubmed.ncbi.nlm.nih.gov]
- To cite this document: BenchChem. [Application Notes and Protocols for Entrectinib-d4 in Drug-Drug Interaction Studies]. BenchChem, [2026]. [Online PDF]. Available at: [<https://www.benchchem.com/product/b15136519/docs#application-notes-and-protocols-for-entrectinib-d4-in-drug-drug-interaction-studies>]

Disclaimer & Data Validity:

The information provided in this document is for Research Use Only (RUO) and is strictly not intended for diagnostic or therapeutic procedures. While BenchChem strives to provide accurate protocols, we make no warranties, express or implied, regarding the fitness of this product for every specific experimental setup.

Technical Support: The protocols provided are for reference purposes. Unsure if this reagent suits your experiment?

Need Industrial/Bulk Grade? [Request Custom Synthesis Quote](#)

BenchChem

Our mission is to be the trusted global source of essential and advanced chemicals, empowering scientists and researchers to drive progress in science and industry.

Contact

Address: 3281 E Guasti Rd
Ontario, CA 91761, United States
Phone: (601) 213-4426
Email: info@benchchem.com

[Contact our Ph.D. Support Team for a compatibility check](#)