

# Application Notes and Protocols for DB18 in Tandem Solar Cell Devices

**Author:** BenchChem Technical Support Team. **Date:** April 2026

## Compound of Interest

Compound Name: DB18  
Cat. No.: B15136889

[Get Quote](#)

For Researchers, Scientists, and Drug Development Professionals

These application notes provide a comprehensive overview of the utilization of the polymer donor **DB18** in tandem organic solar cell (OSC) devices. The information is curated for researchers and scientists in the field of organic photovoltaics.

## Introduction to DB18 in Tandem Solar Cells

The polymer **DB18**, also known as D18, has emerged as a high-performance donor material in the field of organic photovoltaics, primarily recognized for its exceptional power conversion efficiencies (PCE) in single-junction devices, which have been reported to exceed 18%.<sup>[1]</sup> Its application in tandem solar cells is a promising avenue to further enhance the overall efficiency by capturing a broader range of the solar spectrum. In a tandem architecture, two or more solar cells with complementary absorption spectra are stacked. Typically, a wider bandgap front cell absorbs high-energy photons, while a narrower bandgap back cell absorbs lower-energy photons that pass through the front cell.

While extensive data exists for **DB18** in single-junction cells, its specific application in tandem devices is an area of active research. This document synthesizes the available information and

provides protocols based on established techniques for fabricating and characterizing tandem solar cells, adapted for the use of **DB18**.

## Data Presentation: Performance of DB18 in Solar Cells

While specific data for a complete **DB18**-based tandem solar cell is not yet widely published in comprehensive tables, the performance of **DB18** and its derivatives in single-junction devices provides a strong indication of its potential as a component in a tandem architecture. High-performance binary all-polymer solar cells have been achieved with efficiencies of up to 18.39%.<sup>[2]</sup>

For context, the following table summarizes the typical performance parameters of single-junction organic solar cells, which serves as a benchmark for the development of **DB18**-based tandem sub-cells.

Device Type	Donor:Acceptor	Voc (V)	Jsc (mA/cm <sup>2</sup> )	FF (%)	PCE (%)
Single-Junction	D18:L8-BO	-	-	-	19.65
Single-Junction	Terpolymer PL1	-	-	-	18.14
Single-Junction	PM6	-	-	-	15.16
Single-Junction	D18	-	-	-	16.18

Note: The data for D18:L8-BO represents a record efficiency for binary organic solar cells fabricated under high pressure.<sup>[1]</sup> The other values are for comparison and context.<sup>[1]</sup> A comprehensive performance table for a complete **DB18**-based tandem solar cell is not yet available in the reviewed literature.

## Experimental Protocols

The following protocols are generalized from standard procedures for fabricating solution-processed tandem organic solar cells and can be adapted for the use of **DB18** as the donor material in one of the sub-cells, likely the front cell due to its wider bandgap.

## Substrate Preparation

- **Cleaning:** Sequentially clean patterned indium tin oxide (ITO) coated glass substrates in ultrasonic baths of detergent, deionized water, acetone, and isopropanol for 15 minutes each.
- **Drying:** Dry the substrates with a stream of nitrogen gas.
- **UV-Ozone Treatment:** Treat the substrates with UV-ozone for 15-20 minutes to improve the work function of the ITO and enhance hole injection.

## Fabrication of the Front Sub-cell (DB18-based)

- **Hole Transport Layer (HTL) Deposition:**
  - Prepare a solution of PEDOT:PSS (poly(3,4-ethylenedioxythiophene) polystyrene sulfonate).
  - Spin-coat the PEDOT:PSS solution onto the cleaned ITO substrate at 3000-5000 rpm for 30-60 seconds.
  - Anneal the substrate at 140-150°C for 10-15 minutes in a nitrogen-filled glovebox.
- **Active Layer Deposition (DB18:Acceptor Blend):**
  - Prepare a blend solution of **DB18** and a suitable fullerene or non-fullerene acceptor (e.g., PC71BM, Y6) in a chlorinated solvent like chloroform or chlorobenzene. The donor:acceptor ratio and total concentration need to be optimized (e.g., 1:1 to 1:1.5 w/w, total concentration 10-20 mg/mL).
  - Spin-coat the active layer solution onto the HTL at 1000-3000 rpm for 30-60 seconds inside a nitrogen-filled glovebox.

- Anneal the film at a temperature optimized for morphology, typically between 80-120°C, for 5-10 minutes.
- Electron Transport Layer (ETL) Deposition:
  - Prepare a solution for the ETL, for example, a zinc oxide (ZnO) nanoparticle solution or a solution of PFN-Br.
  - Spin-coat the ETL solution onto the active layer.
  - Anneal as required by the specific ETL material.

## Interconnecting Layer (ICL) Deposition

The ICL is a critical component that connects the front and back sub-cells in series. It should be optically transparent and facilitate efficient recombination of electrons from the front cell and holes from the back cell.

- P-type Layer: Deposit a thin layer of a p-type material, such as PEDOT:PSS or MoOx, on top of the front cell's ETL.
- N-type Layer: Deposit a thin layer of an n-type material, such as ZnO nanoparticles or a pH-neutral conjugated polyelectrolyte, on top of the p-type layer.

## Fabrication of the Back Sub-cell

The back sub-cell should have a narrower bandgap to absorb lower-energy photons. The fabrication process is similar to the front cell, involving the deposition of an HTL, the narrow-bandgap active layer, and an ETL.

## Top Electrode Deposition

Deposit a top metal electrode, such as silver (Ag) or aluminum (Al), through thermal evaporation under high vacuum (<10<sup>-6</sup> Torr) using a shadow mask to define the device area.

## Mandatory Visualizations

### Tandem Solar Cell Device Architecture

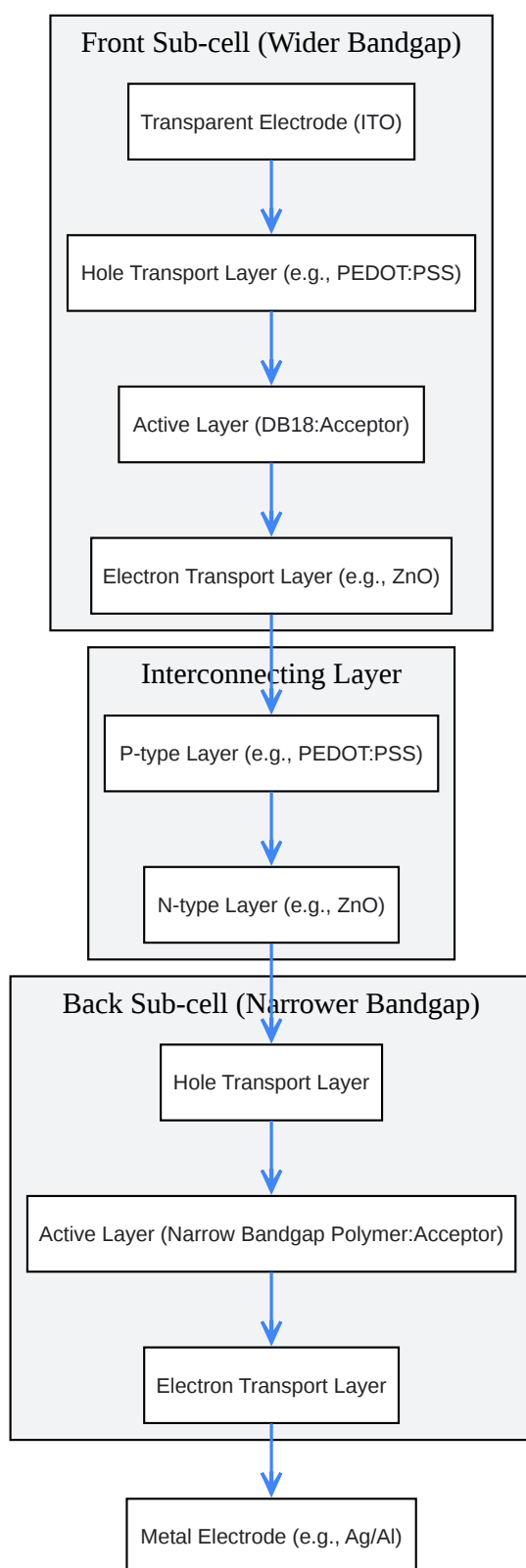

[Click to download full resolution via product page](#)

Caption: Schematic of a solution-processed tandem organic solar cell.

## Experimental Workflow for Tandem Cell Fabrication

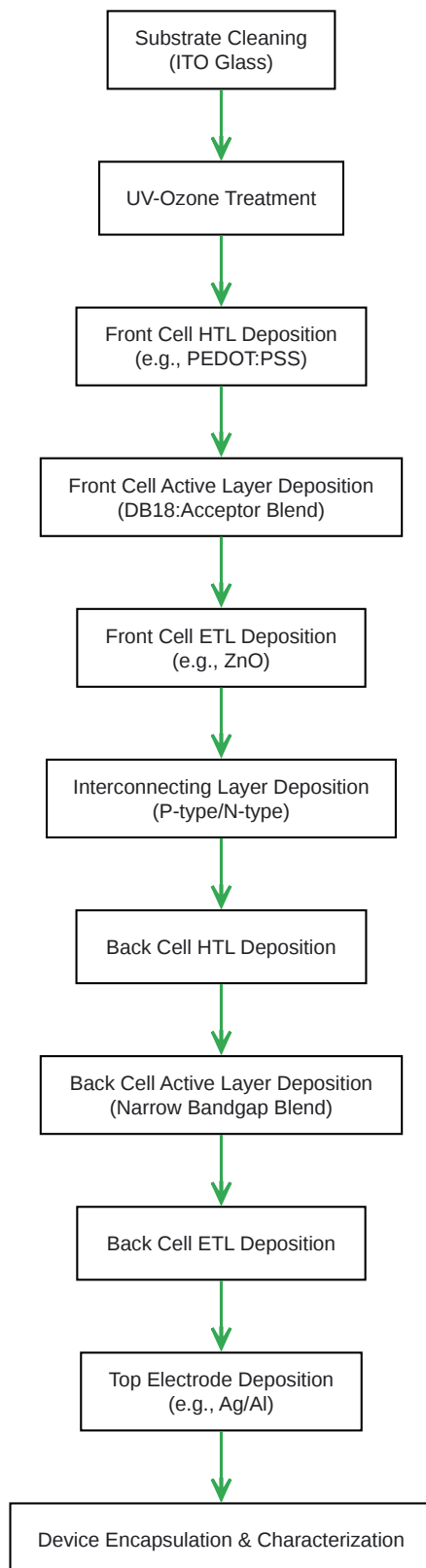

[Click to download full resolution via product page](#)

Caption: Step-by-step workflow for fabricating a tandem solar cell.

## Charge Generation and Recombination in a Tandem Device

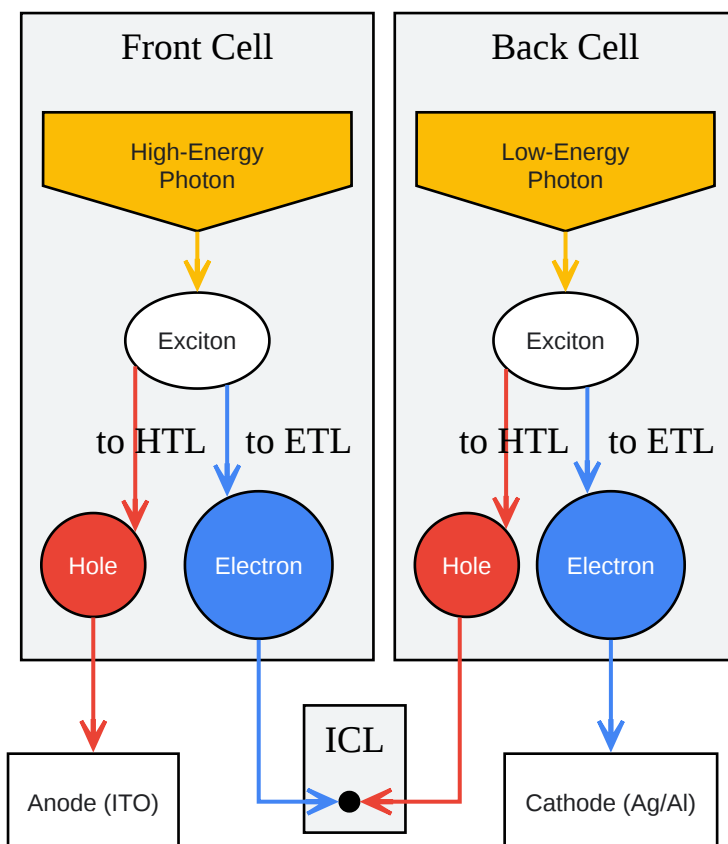

[Click to download full resolution via product page](#)

Caption: Charge carrier flow in a two-terminal tandem solar cell.

### Need Custom Synthesis?

BenchChem offers custom synthesis for rare earth carbides and specific isotopic labeling.

Email: [info@benchchem.com](mailto:info@benchchem.com) or [Request Quote Online](#).

## References

- 1. [researchgate.net](https://www.researchgate.net) [researchgate.net]

- [2. Efficiency limits in wide-bandgap Ge-containing donor polymer:non-fullerene acceptor bulk heterojunction solar cells — Fluxim \[fluxim.com\]](#)
- To cite this document: BenchChem. [Application Notes and Protocols for DB18 in Tandem Solar Cell Devices]. BenchChem, [2026]. [Online PDF]. Available at: [<https://www.benchchem.com/product/b15136889/docs#application-notes-and-protocols-for-db18-in-tandem-solar-cell-devices>]

---

**Disclaimer & Data Validity:**

The information provided in this document is for Research Use Only (RUO) and is strictly not intended for diagnostic or therapeutic procedures. While BenchChem strives to provide accurate protocols, we make no warranties, express or implied, regarding the fitness of this product for every specific experimental setup.

**Technical Support:** The protocols provided are for reference purposes. Unsure if this reagent suits your experiment?

**Need Industrial/Bulk Grade?** [Request Custom Synthesis Quote](#)

## BenchChem

Our mission is to be the trusted global source of essential and advanced chemicals, empowering scientists and researchers to drive progress in science and industry.

### Contact

Address: 3281 E Guasti Rd  
Ontario, CA 91761, United States  
Phone: (601) 213-4426  
Email: [info@benchchem.com](mailto:info@benchchem.com)

[Contact our Ph.D. Support Team for a compatibility check](#)