

Application Note: A Robust Protocol for Recombinant PIM2 Protein Purification

Author: BenchChem Technical Support Team. **Date:** April 2026

Compound of Interest

Compound Name: *Pim-IN-2*
Cat. No.: *B15136001*

[Get Quote](#)

Audience: Researchers, scientists, and drug development professionals.

Introduction: The Proviral Integration site for Moloney murine leukemia virus 2 (PIM2) is a serine/threonine kinase that plays a crucial role as an oncogene in various human cancers, including leukemia, myeloma, and several solid tumors.[1][2][3] PIM2 is a key regulator of cell survival, proliferation, and cell cycle progression.[1][2] It exerts its function by phosphorylating a multitude of downstream substrates involved in critical signaling pathways. Given its significance in cancer pathogenesis, the availability of highly purified and active recombinant PIM2 protein is essential for biochemical and structural studies, inhibitor screening, and the development of novel therapeutic agents. This application note provides a detailed protocol for the expression and purification of recombinant PIM2 kinase.

PIM2 Signaling Pathway

The PIM2 kinase is a constitutively active enzyme whose activity is primarily regulated at the level of gene expression. Its transcription is induced by a variety of cytokines and growth factors through the activation of transcription factors such as STAT3, STAT5, and NF- κ B. Once expressed, PIM2 phosphorylates a range of downstream targets to promote cell survival and proliferation.

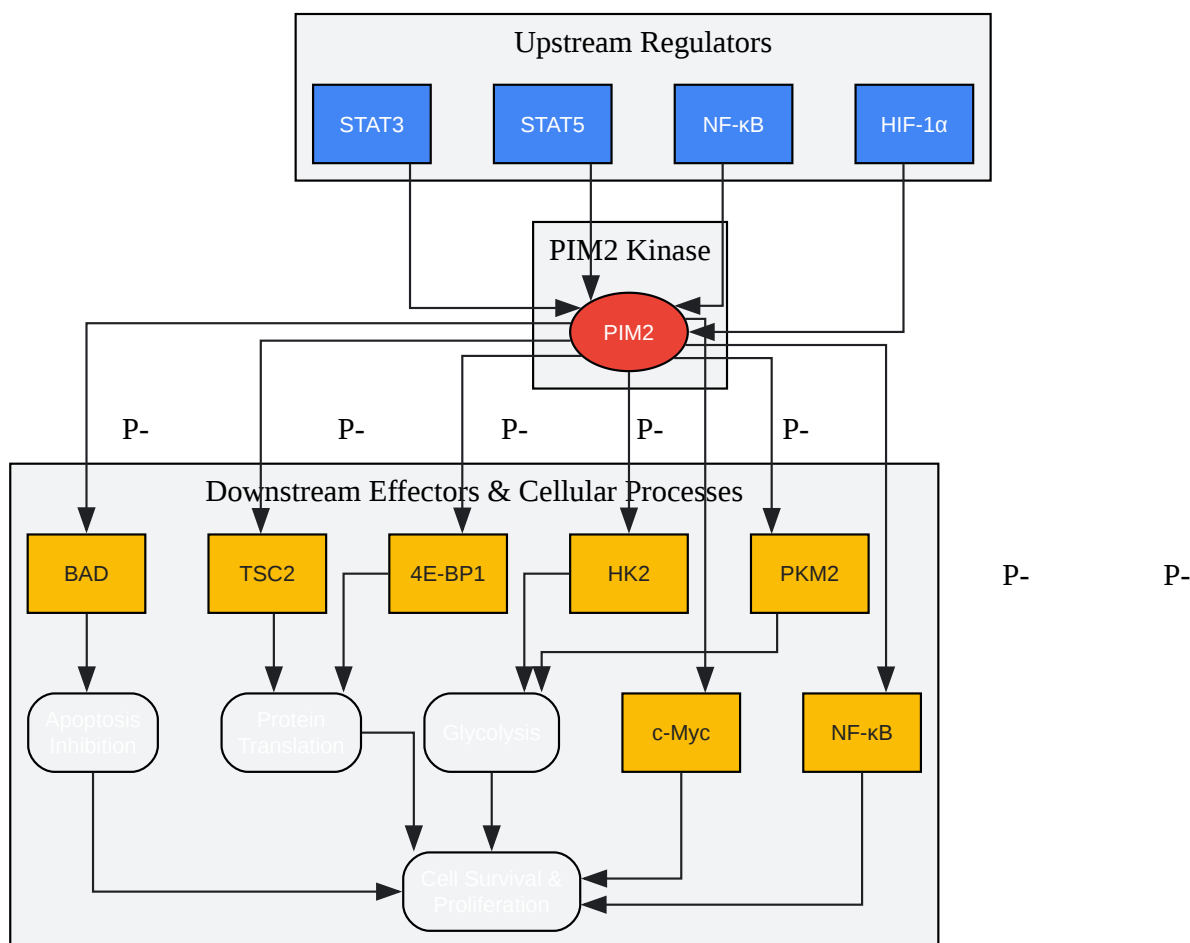

[Click to download full resolution via product page](#)

Caption: PIM2 signaling cascade overview.

Recombinant PIM2 Purification Workflow

The purification of recombinant PIM2 from *E. coli* typically involves expression, cell lysis, affinity chromatography, and an optional polishing step like size-exclusion chromatography. As PIM2 is often expressed in insoluble inclusion bodies, a refolding step is commonly required.

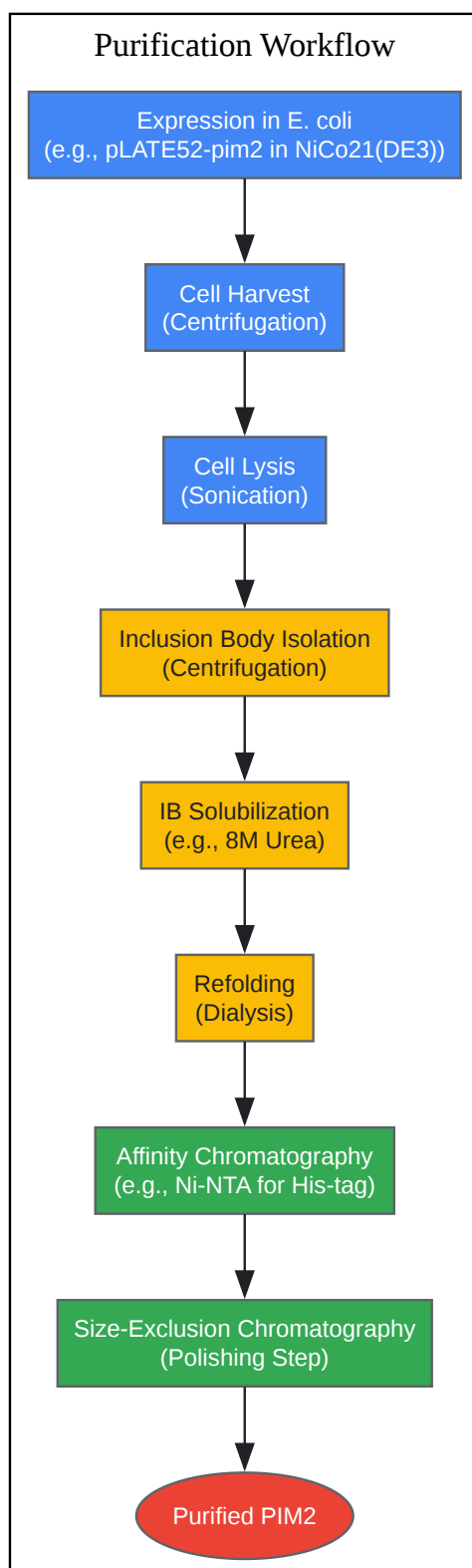

[Click to download full resolution via product page](#)

Caption: Recombinant PIM2 purification workflow.

Experimental Protocols

This protocol is adapted for a His-tagged PIM2 construct expressed in *E. coli*, which results in the formation of inclusion bodies.

Materials and Reagents

- Lysis Buffer: 50 mM Tris-HCl pH 8.0, 300 mM NaCl, 10 mM imidazole, 1 mM PMSF, 1 mg/mL lysozyme.
- Inclusion Body Wash Buffer: 50 mM Tris-HCl pH 8.0, 100 mM NaCl, 1% Triton X-100.
- Solubilization Buffer: 50 mM Tris-HCl pH 8.0, 100 mM NaCl, 8 M Urea, 10 mM β -mercaptoethanol.
- Refolding Buffer: 50 mM Tris-HCl pH 8.0, 250 mM NaCl, 500 mM L-Arginine, 1 mM reduced glutathione, 0.1 mM oxidized glutathione.
- Affinity Chromatography Buffers:
 - Binding Buffer (Buffer A): 50 mM Tris-HCl pH 8.0, 300 mM NaCl, 10 mM imidazole.
 - Wash Buffer (Buffer B): 50 mM Tris-HCl pH 8.0, 300 mM NaCl, 20 mM imidazole.
 - Elution Buffer (Buffer C): 50 mM Tris-HCl pH 8.0, 300 mM NaCl, 250 mM imidazole.
- Size-Exclusion Chromatography Buffer: 50 mM HEPES pH 7.5, 300 mM NaCl, 20% glycerol, 0.5 mM TCEP.
- Resin: Ni-NTA Agarose.

Protocol

Step 1: Expression of Recombinant PIM2

- Transform *E. coli* cells (e.g., NiCo21(DE3)) with a PIM2 expression vector (e.g., pLATE52-pim2).
- Inoculate a starter culture and grow overnight at 37°C.

- Use the starter culture to inoculate a larger volume of LB medium and grow at 37°C until the OD600 reaches 0.6-0.8.
- Induce protein expression by adding IPTG to a final concentration of 0.5-1 mM.
- Continue to culture for 4-6 hours at 30°C.
- Harvest the cells by centrifugation at 5,000 x g for 15 minutes at 4°C.

Step 2: Cell Lysis and Inclusion Body Isolation

- Resuspend the cell pellet in ice-cold Lysis Buffer.
- Lyse the cells by sonication on ice.
- Centrifuge the lysate at 15,000 x g for 30 minutes at 4°C to pellet the inclusion bodies.
- Discard the supernatant.
- Wash the inclusion body pellet with Inclusion Body Wash Buffer and centrifuge again. Repeat this step twice.

Step 3: Solubilization and Refolding

- Resuspend the washed inclusion body pellet in Solubilization Buffer.
- Stir gently for 1-2 hours at room temperature to completely solubilize the protein.
- Clarify the solubilized protein by centrifugation at 20,000 x g for 30 minutes.
- Perform refolding by adding the supernatant drop-wise into a large volume of stirred, ice-cold Refolding Buffer.
- Allow the protein to refold overnight at 4°C with gentle stirring.
- Concentrate the refolded protein and dialyze against Affinity Chromatography Binding Buffer (Buffer A).

Step 4: Affinity Chromatography

- Load the dialyzed protein solution onto a pre-equilibrated Ni-NTA agarose column.
- Wash the column with 10-20 column volumes of Binding Buffer (Buffer A).
- Wash the column with 10 column volumes of Wash Buffer (Buffer B) to remove non-specifically bound proteins.
- Elute the His-tagged PIM2 protein with Elution Buffer (Buffer C).
- Collect the fractions and analyze for the presence of PIM2 by SDS-PAGE.

Step 5: Size-Exclusion Chromatography (Optional Polishing Step)

- Pool the fractions containing PIM2 from the affinity chromatography step.
- Concentrate the pooled fractions.
- Load the concentrated protein onto a size-exclusion chromatography column (e.g., Sephacryl-200) pre-equilibrated with Size-Exclusion Chromatography Buffer.
- Collect fractions and analyze by SDS-PAGE for purity.
- Pool the purest fractions, determine the concentration, and store at -80°C.

Data Presentation

The following table summarizes typical yields and purity that can be expected at various stages of the purification process, based on published data.

Purification Stage	Starting Material	Total Protein (mg)	Purity (%)	Notes
Inclusion Body Isolation	250 mL E. coli culture	34.72	~50-60%	Wet weight of inclusion bodies was 312 mg.
After Refolding	20 mg of solubilized IB	18.4	~70-80%	Protein recovered after dialysis.
After Affinity Chromatography	18.4 mg of refolded protein	~10-15	>90%	Estimated yield after Ni-NTA purification.
After Size-Exclusion	~10-15 mg from affinity	~5-10	>95%	Final yield of highly pure, monomeric PIM2.

Conclusion

This protocol provides a comprehensive method for the expression and purification of recombinant PIM2 kinase from E. coli. The procedure yields a high-purity protein suitable for a wide range of applications, from enzymatic assays for inhibitor screening to structural biology studies. The inclusion of a refolding step is critical for obtaining active, soluble protein from inclusion bodies. The final purity can be significantly enhanced by an optional size-exclusion chromatography step.

Need Custom Synthesis?

BenchChem offers custom synthesis for rare earth carbides and specific isotopic labeling.

Email: info@benchchem.com or [Request Quote Online](#).

References

- [1. Protein kinase PIM2: A simple PIM family kinase with complex functions in cancer metabolism and therapeutics - PMC \[pmc.ncbi.nlm.nih.gov\]](#)
- [2. researchgate.net \[researchgate.net\]](#)
- [3. Protein kinase PIM2: A simple PIM family kinase with complex functions in cancer metabolism and therapeutics \[jcancer.org\]](#)
- To cite this document: BenchChem. [Application Note: A Robust Protocol for Recombinant PIM2 Protein Purification]. BenchChem, [2026]. [Online PDF]. Available at: [\[https://www.benchchem.com/product/b15136001/docs#application-note-a-robust-protocol-for-recombinant-pim2-protein-purification\]](https://www.benchchem.com/product/b15136001/docs#application-note-a-robust-protocol-for-recombinant-pim2-protein-purification)

Disclaimer & Data Validity:

The information provided in this document is for Research Use Only (RUO) and is strictly not intended for diagnostic or therapeutic procedures. While BenchChem strives to provide accurate protocols, we make no warranties, express or implied, regarding the fitness of this product for every specific experimental setup.

Technical Support: The protocols provided are for reference purposes. Unsure if this reagent suits your experiment?

Need Industrial/Bulk Grade? [Request Custom Synthesis Quote](#)

BenchChem

Our mission is to be the trusted global source of essential and advanced chemicals, empowering scientists and researchers to drive progress in science and industry.

Contact

Address: 3281 E Guasti Rd
Ontario, CA 91761, United States
Phone: (601) 213-4426
Email: info@benchchem.com

Contact our Ph.D. Support Team for a compatibility check