

# An In-depth Technical Guide to the DNA Alkylation Mechanism of Duocarmycin DM

**Author:** BenchChem Technical Support Team. **Date:** April 2026

## Compound of Interest

Compound Name: MA-PEG4-VC-PAB-DMEA-  
duocarmycin DM

Cat. No.: B15136955

[Get Quote](#)

For Researchers, Scientists, and Drug Development Professionals

## Executive Summary

Duocarmycin DM, a potent synthetic analogue of the natural product duocarmycin, is a DNA alkylating agent with remarkable cytotoxicity against a broad spectrum of cancer cell lines. Its mechanism of action involves a highly specific, multi-step process initiated by sequence-selective binding to the minor groove of DNA. This binding event catalyzes a conformational change in the duocarmycin DM molecule, activating its spirocyclopropylcyclohexadienone warhead for nucleophilic attack by the N3 atom of adenine bases, preferentially within AT-rich sequences. The resulting covalent adduct distorts the DNA helix, leading to the activation of cellular DNA damage response pathways, cell cycle arrest, and ultimately, apoptotic cell death. This guide provides a comprehensive technical overview of the DNA alkylation mechanism of duocarmycin DM, including quantitative data on its activity, detailed experimental protocols for its study, and visualizations of the key molecular and cellular events.

## The Core Mechanism: DNA Alkylation

The DNA alkylation mechanism of duocarmycin DM is a sophisticated process that can be dissected into three key phases:

- **Minor Groove Binding and Sequence Recognition:** Duocarmycin DM possesses a characteristic curved indole structure that allows it to bind snugly within the minor groove of duplex DNA.<sup>[1][2]</sup> This interaction is highly sequence-selective, with a strong preference for AT-rich regions of DNA.<sup>[3][4]</sup> The trimethoxyindole portion of the molecule is primarily responsible for this DNA binding specificity.<sup>[5]</sup>
- **Conformational Activation:** Upon binding to the minor groove, the DNA itself acts as a catalyst, inducing a conformational change in the duocarmycin DM molecule. This "shape-dependent catalysis" disrupts the stabilizing vinylogous amide conjugation of the alkylating subunit.<sup>[6][7]</sup>
- **Nucleophilic Attack and Adduct Formation:** The conformational change activates the spirocyclopropylcyclohexadienone "warhead," rendering the least substituted carbon of the cyclopropane ring highly electrophilic. This prompts a nucleophilic attack from the N3 position of an adenine base within the DNA minor groove, leading to the formation of a stable, covalent adduct.<sup>[3][7]</sup> This alkylation is essentially irreversible under physiological conditions and causes significant distortion of the DNA helix.<sup>[3]</sup>

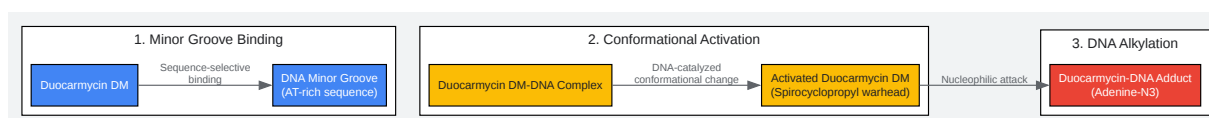

[Click to download full resolution via product page](#)

**Figure 1:** The core mechanism of DNA alkylation by Duocarmycin DM.

## Quantitative Data on Duocarmycin Activity

The potent cytotoxic activity of duocarmycin DM and its analogues is reflected in their low picomolar to nanomolar IC<sub>50</sub> values across a wide range of human cancer cell lines.

Compound	Cell Line	Cancer Type	IC50 (pM)
Duocarmycin DM	HT-29	Colon Carcinoma	22[2][3]
CL1-5	Lung Adenocarcinoma	13.8[2][3]	
Caski	Cervical Carcinoma	3.87[2][3]	
EJ	Bladder Carcinoma	15.4[2][3]	
LS174T	Colon Carcinoma	7.31[2][3]	
Duocarmycin SA	L1210	Murine Leukemia	~8[5]
10a (analogue)	Murine Leukemia	37[5][8]	
10d (analogue)	Murine Leukemia	35,000[8]	
10e (analogue)	Murine Leukemia	370,000[8]	

Note on DNA Binding Affinity (Kd): While the irreversible nature of the covalent bond formation makes precise determination of the equilibrium dissociation constant (Kd) for the initial non-covalent binding challenging, techniques like the fluorescent intercalator displacement (FID) assay have been employed to demonstrate the high affinity of duocarmycins for their target DNA sequences.[5] These studies show a correlation between hydrophobicity and DNA binding, which in turn influences the alkylation efficiency and cytotoxic potency.[8]

## Cellular Consequences of DNA Alkylation

The formation of duocarmycin-DNA adducts triggers a cascade of cellular events, culminating in cell death.

### DNA Damage Response and Cell Cycle Arrest

The distortion of the DNA helix by duocarmycin adducts is recognized by the cell's DNA damage response (DDR) machinery. This primarily activates the ATR (Ataxia Telangiectasia and Rad3-related) - Chk1 (Checkpoint kinase 1) signaling pathway.[3] ATR, a key sensor of single-stranded DNA and replication stress, phosphorylates and activates Chk1.[9] Activated Chk1 then phosphorylates downstream targets, such as Cdc25 phosphatases, leading to their

degradation and subsequent G2/M cell cycle arrest, providing the cell with time to repair the DNA damage.[10]

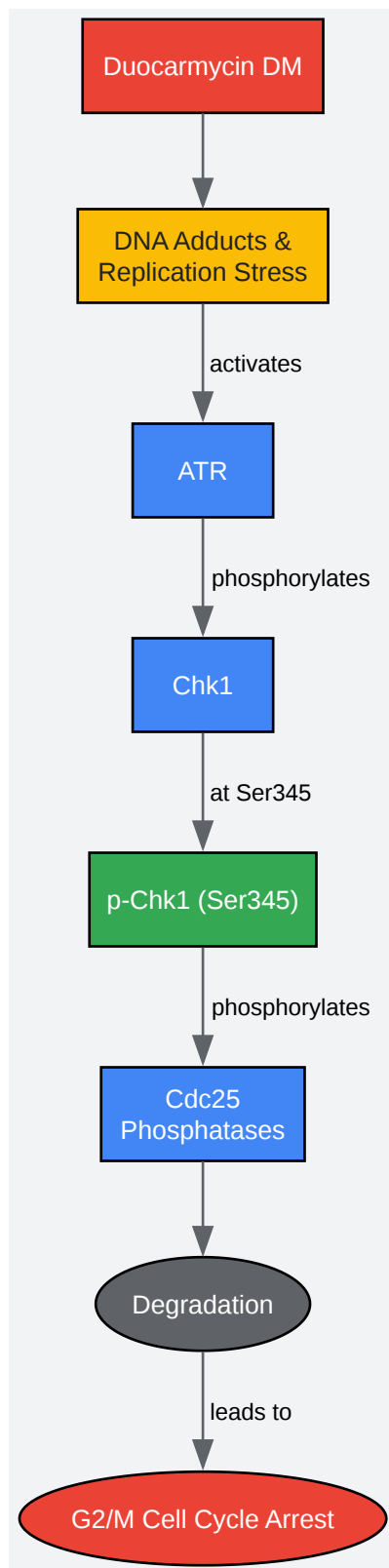

[Click to download full resolution via product page](#)

**Figure 2:** Duocarmycin DM-induced ATR-Chk1 signaling pathway leading to cell cycle arrest.

## Apoptosis

If the DNA damage is too extensive to be repaired, the cell undergoes programmed cell death, or apoptosis. Duocarmycin-induced apoptosis is primarily mediated through the intrinsic (mitochondrial) pathway, which involves the activation of a cascade of cysteine-aspartic proteases known as caspases. The process is initiated by the activation of initiator caspases, such as caspase-9, which then cleave and activate executioner caspases, like caspase-3.[11] [12] Activated caspase-3 is responsible for the cleavage of numerous cellular substrates, leading to the characteristic morphological and biochemical hallmarks of apoptosis, including DNA fragmentation.[10]

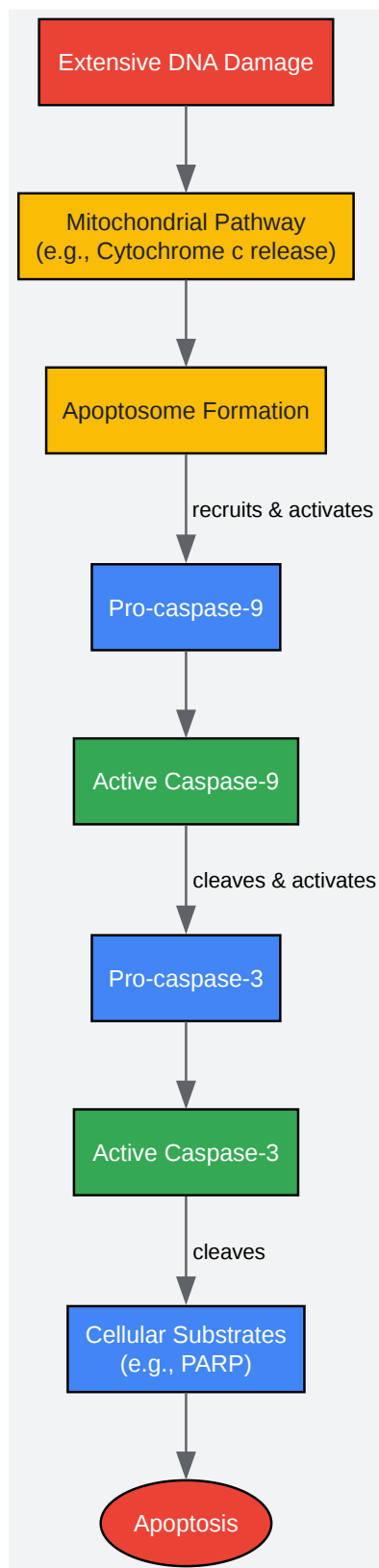

[Click to download full resolution via product page](#)

**Figure 3:** Duocarmycin DM-induced intrinsic apoptosis pathway.

## Detailed Experimental Protocols

The following are detailed methodologies for key experiments used to elucidate the DNA alkylation mechanism and cellular effects of duocarmycin DM.

### DNase I Footprinting Assay for DNA Binding Sequence Specificity

This assay identifies the specific DNA sequences where duocarmycin DM binds and protects the DNA from cleavage by DNase I.

Materials:

- Plasmid DNA containing the sequence of interest.
- Restriction enzymes.
- T4 Polynucleotide Kinase (PNK) and [ $\gamma$ - $^{32}$ P]ATP.
- DNase I (RNase-free).
- Duocarmycin DM.
- 2X Footprinting Buffer (100 mM KCl, 20 mM MgCl<sub>2</sub>, 40 mM Tris pH 8.0, 0.2 mM EDTA).
- Stop Solution (0.1 M EDTA, 0.6 M NH<sub>4</sub>OAc, 20  $\mu$ g/ml sonicated salmon sperm DNA).
- Phenol:Chloroform:Isoamyl Alcohol (25:24:1).
- Ethanol (100% and 70%).
- Sequencing Gel (6-8% polyacrylamide, 7M Urea).
- Formamide Loading Dye.

Procedure:

- **Probe Preparation:** a. Digest plasmid DNA with a suitable restriction enzyme to generate a fragment containing the target sequence. b. Dephosphorylate the 5' ends with calf intestinal phosphatase. c. End-label the DNA fragment with [ $\gamma$ - $^{32}\text{P}$ ]ATP using T4 PNK. d. Purify the labeled probe using a spin column.
- **Binding Reaction:** a. In a microcentrifuge tube, mix the radiolabeled DNA probe (10,000-20,000 cpm) with varying concentrations of duocarmycin DM in 1X Footprinting Buffer. b. Include a no-drug control. c. Incubate at room temperature for 30 minutes to allow binding to reach equilibrium.
- **DNase I Digestion:** a. Add a freshly diluted solution of DNase I to each reaction. The optimal concentration of DNase I must be determined empirically to achieve on average one cut per DNA molecule. b. Incubate for a short, precise time (e.g., 1-2 minutes) at room temperature. c. Stop the reaction by adding an excess of Stop Solution.
- **DNA Purification and Analysis:** a. Extract the DNA with phenol:chloroform and precipitate with ethanol. b. Wash the DNA pellet with 70% ethanol and air dry. c. Resuspend the pellet in Formamide Loading Dye. d. Denature the samples by heating at 90°C for 5 minutes and then place on ice. e. Load the samples onto a sequencing gel alongside a Maxam-Gilbert sequencing ladder of the same DNA fragment. f. After electrophoresis, dry the gel and expose it to X-ray film or a phosphorimager screen. g. The "footprint" will appear as a region of protection from DNase I cleavage in the lanes containing duocarmycin DM compared to the control lane.

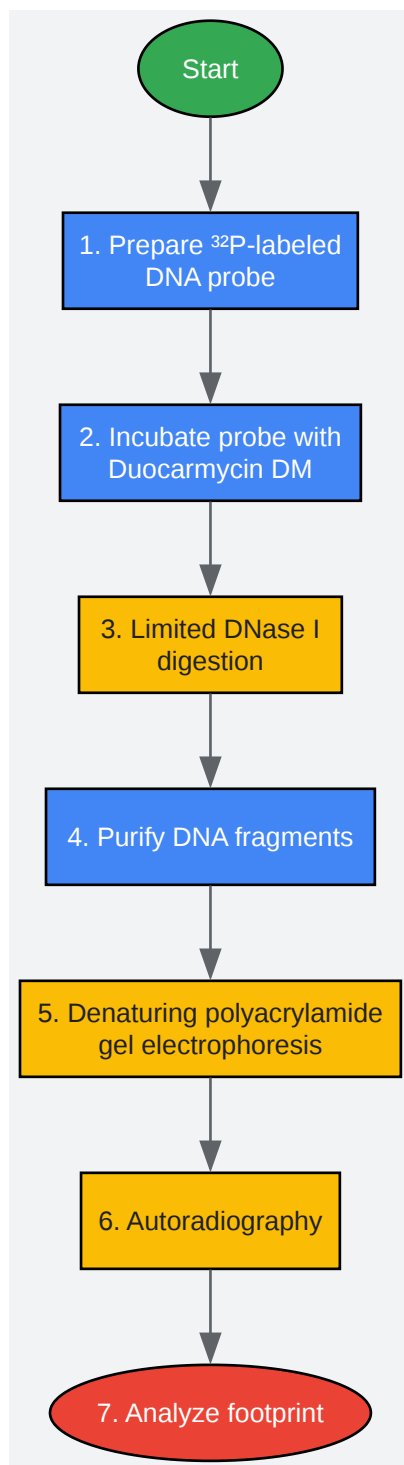

[Click to download full resolution via product page](#)

**Figure 4:** Experimental workflow for DNase I footprinting.

## Comet Assay (Single-Cell Gel Electrophoresis) for DNA Strand Breaks

The comet assay is a sensitive method for detecting DNA strand breaks in individual cells.

Materials:

- Treated and untreated cells.
- Low melting point agarose.
- Normal melting point agarose.
- Lysis Solution (2.5 M NaCl, 100 mM EDTA, 10 mM Tris, pH 10, with 1% Triton X-100 and 10% DMSO added fresh).
- Alkaline Electrophoresis Buffer (300 mM NaOH, 1 mM EDTA, pH >13).
- Neutralization Buffer (0.4 M Tris, pH 7.5).
- DNA stain (e.g., SYBR Green or propidium iodide).
- Microscope slides.

Procedure:

- Cell Preparation and Embedding: a. Harvest cells and resuspend in ice-cold PBS at a concentration of  $1 \times 10^5$  cells/mL. b. Mix the cell suspension with molten low melting point agarose (at 37°C) at a 1:10 (v/v) ratio. c. Pipette the cell/agarose mixture onto a microscope slide pre-coated with normal melting point agarose. d. Cover with a coverslip and allow the agarose to solidify on a cold plate.
- Cell Lysis: a. Gently remove the coverslip and immerse the slides in cold Lysis Solution for at least 1 hour at 4°C.
- Alkaline Unwinding and Electrophoresis: a. Place the slides in a horizontal gel electrophoresis tank filled with fresh, cold Alkaline Electrophoresis Buffer. b. Allow the DNA to

unwind for 20-40 minutes in the dark. c. Apply a voltage (e.g., 25 V, 300 mA) for 20-30 minutes.

- Neutralization and Staining: a. Gently remove the slides from the electrophoresis tank and immerse them in Neutralization Buffer for 5 minutes. Repeat this step three times. b. Stain the slides with a suitable DNA stain.
- Visualization and Analysis: a. Visualize the comets using a fluorescence microscope. b. Quantify the extent of DNA damage using specialized software to measure parameters such as tail length, tail intensity, and tail moment.

## Western Blot Analysis of Caspase Activation and Chk1 Phosphorylation

Western blotting is used to detect the cleavage of caspases (a hallmark of apoptosis) and the phosphorylation of Chk1 (an indicator of ATR activation).

Materials:

- Treated and untreated cell lysates.
- Protein assay reagent (e.g., BCA).
- SDS-PAGE gels.
- PVDF or nitrocellulose membranes.
- Blocking Buffer (e.g., 5% non-fat milk or BSA in TBST).
- Primary antibodies (e.g., anti-cleaved caspase-3, anti-cleaved caspase-9, anti-phospho-Chk1 (Ser345), anti-total Chk1, and a loading control like anti- $\beta$ -actin).
- HRP-conjugated secondary antibodies.
- Chemiluminescent substrate.

Procedure:

- Protein Extraction and Quantification: a. Lyse cells in RIPA buffer containing protease and phosphatase inhibitors. b. Quantify protein concentration using a BCA assay.
- SDS-PAGE and Transfer: a. Denature protein lysates by boiling in Laemmli buffer. b. Separate proteins by SDS-PAGE. c. Transfer proteins to a PVDF or nitrocellulose membrane.
- Immunoblotting: a. Block the membrane in Blocking Buffer for 1 hour at room temperature. b. Incubate the membrane with the primary antibody overnight at 4°C. c. Wash the membrane three times with TBST. d. Incubate with the appropriate HRP-conjugated secondary antibody for 1 hour at room temperature. e. Wash the membrane three times with TBST.
- Detection: a. Incubate the membrane with a chemiluminescent substrate. b. Detect the signal using an imaging system. c. Analyze the band intensities to determine the levels of cleaved caspases and phosphorylated Chk1 relative to total protein and the loading control.

## Conclusion

Duocarmycin DM represents a class of highly potent DNA alkylating agents with a sophisticated mechanism of action that leverages the structure of its DNA target for activation. Its sequence-selective binding to the minor groove, followed by a DNA-catalyzed activation and subsequent alkylation of adenine, leads to significant DNA damage. This damage, in turn, activates robust cellular responses, including cell cycle arrest and apoptosis, which are central to its anticancer activity. The detailed understanding of this mechanism, facilitated by the experimental approaches outlined in this guide, is crucial for the rational design of next-generation duocarmycin-based therapeutics, including antibody-drug conjugates, with improved efficacy and tumor selectivity.

### *Need Custom Synthesis?*

*BenchChem offers custom synthesis for rare earth carbides and specific isotopic labeling.*

*Email: [info@benchchem.com](mailto:info@benchchem.com) or [Request Quote Online](#).*

## References

- [1. DNase I footprinting \[gene.mie-u.ac.jp\]](#)

- [2. DNase I footprinting of small molecule binding sites on DNA - PubMed \[pubmed.ncbi.nlm.nih.gov\]](#)
- [3. medchemexpress.com \[medchemexpress.com\]](#)
- [4. medchemexpress.com \[medchemexpress.com\]](#)
- [5. researchgate.net \[researchgate.net\]](#)
- [6. Are the Duocarmycin and CC-1065 DNA Alkylation Reactions Acid-Catalyzed? Solvolysis pH-Rate Profiles Suggest They Are Not - PubMed \[pubmed.ncbi.nlm.nih.gov\]](#)
- [7. CC-1065 and the duocarmycins: unraveling the keys to a new class of naturally derived DNA alkylating agents - PubMed \[pubmed.ncbi.nlm.nih.gov\]](#)
- [8. A Fundamental Relationship Between Hydrophobic Properties and Biological Activity for the Duocarmycin Class of DNA Alkylating Antitumor Drugs: Hydrophobic Binding-Driven-Bonding - PMC \[pmc.ncbi.nlm.nih.gov\]](#)
- [9. Assessment of Chk1 phosphorylation as a pharmacodynamic biomarker of Chk1 inhibition - PMC \[pmc.ncbi.nlm.nih.gov\]](#)
- [10. bio-rad-antibodies.com \[bio-rad-antibodies.com\]](#)
- [11. devtoolsdaily.com \[devtoolsdaily.com\]](#)
- [12. m.youtube.com \[m.youtube.com\]](#)
- [To cite this document: BenchChem. \[An In-depth Technical Guide to the DNA Alkylation Mechanism of Duocarmycin DM\]. BenchChem, \[2026\]. \[Online PDF\]. Available at: \[https://www.benchchem.com/product/b15136955/docs#an-in-depth-technical-guide-to-the-dna-alkylation-mechanism-of-duocarmycin-dm\]](#)

---

### Disclaimer & Data Validity:

The information provided in this document is for Research Use Only (RUO) and is strictly not intended for diagnostic or therapeutic procedures. While BenchChem strives to provide accurate protocols, we make no warranties, express or implied, regarding the fitness of this product for every specific experimental setup.

**Technical Support:** The protocols provided are for reference purposes. Unsure if this reagent suits your experiment?

**Need Industrial/Bulk Grade?** [Request Custom Synthesis Quote](#)

# BenchChem

Our mission is to be the trusted global source of essential and advanced chemicals, empowering scientists and researchers to drive progress in science and industry.

## Contact

Address: 3281 E Guasti Rd

Ontario, CA 91761, United States

Phone: (601) 213-4426

Email: [info@benchchem.com](mailto:info@benchchem.com)

[Contact our Ph.D. Support Team for a compatibility check](#)