

A Comparative Guide to Ubc13 Inhibitors: ML307 vs. NSC697923

Author: BenchChem Technical Support Team. **Date:** April 2026

Compound of Interest

Compound Name: ML307
Cat. No.: B15136055

[Get Quote](#)

For researchers, scientists, and drug development professionals, this guide provides a comprehensive comparison of two prominent Ubc13 inhibitors, **ML307** and NSC697923. This document outlines their inhibitory activities, mechanisms of action, and the experimental frameworks used to characterize them.

The E2 ubiquitin-conjugating enzyme Ubc13 plays a pivotal role in cellular signaling pathways, particularly in the inflammatory response and DNA damage repair, by catalyzing the formation of lysine 63 (K63)-linked polyubiquitin chains. Its involvement in various diseases has made it a significant target for therapeutic intervention. This guide focuses on a direct comparison of two small molecule inhibitors of Ubc13: **ML307**, a potent and selective inhibitor, and NSC697923, a covalent inhibitor with demonstrated cellular activity.

Quantitative Comparison of Inhibitor Activity

The following table summarizes the key quantitative data for **ML307** and NSC697923, offering a side-by-side view of their potency and characteristics.

Feature	ML307	NSC697923
Biochemical Potency (IC50)	781 nM[1]	Not explicitly reported in a comparable biochemical assay. Effective in cellular assays at 1-2 μ M.
Mechanism of Action	First-in-class small molecule inhibitor of Ubc13 enzyme activity.[1][2]	Covalent inhibitor that targets the active site cysteine of Ubc13, preventing the formation of the Ubc13-ubiquitin thioester conjugate. [3][4][5][6]
Primary Assay for Potency	Time-Resolved Fluorescence Resonance Energy Transfer (TR-FRET)[1][2]	Inhibition of Ubc13~Ub conjugate formation in vitro and cellular assays for NF- κ B inhibition and apoptosis.[3][7]
Selectivity	>128-fold selective against Caspase-3. Not inhibitory in a TR-FRET assay for Bfl-1.[1][2]	Selective for Ubc13; has no effect on UbcH5c activity.[8][9]

Experimental Methodologies

Understanding the experimental context is crucial for interpreting the inhibitory data. Below are detailed descriptions of the key assays used to characterize **ML307** and NSC697923.

ML307: TR-FRET Biochemical Assay

The potency of **ML307** was determined using a time-resolved fluorescence resonance energy transfer (TR-FRET) based ubiquitination assay.[2] This in vitro assay monitors the formation of polyubiquitin chains by Ubc13 in conjunction with its cofactor UEV1a.

- Principle: The assay measures the proximity of differently labeled ubiquitin molecules. One population of ubiquitin is labeled with a terbium (Tb) chelate (the FRET donor), and another is labeled with fluorescein (the FRET acceptor). When Ubc13-UEV1a catalyzes the formation

of polyubiquitin chains, the donor and acceptor molecules are brought into close proximity, resulting in a FRET signal.

- Procedure:
 - Recombinant E1 activating enzyme, Ubc13, and UEV1a are combined in a reaction buffer.
 - Terbium-labeled and fluorescein-labeled ubiquitin molecules are added to the mixture.
 - The ubiquitination reaction is initiated by the addition of ATP.
 - **ML307** at varying concentrations is included to assess its inhibitory effect on polyubiquitin chain formation.
 - The TR-FRET signal is measured over time. A decrease in the FRET signal indicates inhibition of Ubc13 activity.
- Data Analysis: The IC₅₀ value is calculated by plotting the percentage of inhibition against the inhibitor concentration and fitting the data to a dose-response curve.

NSC697923: In Vitro and Cellular Assays

The inhibitory activity of NSC697923 was characterized through a combination of in vitro and cell-based assays.

- In Vitro Ubiquitination Assay: This assay directly assesses the formation of the Ubc13-ubiquitin (Ubc13~Ub) thioester conjugate.^[7]
 - Procedure: Purified E1 enzyme, Ubc13, Uev1A, and ubiquitin are incubated in a reaction buffer. The reaction is initiated with ATP. NSC697923 is added at various concentrations. The reaction products are then analyzed by non-reducing SDS-PAGE and Western blotting using an anti-Ubc13 antibody to visualize the Ubc13~Ub conjugate.
 - Endpoint: Inhibition is determined by the reduction in the band intensity corresponding to the Ubc13~Ub conjugate.
- Cell-Based NF- κ B Reporter Assay: This assay measures the effect of the inhibitor on the NF- κ B signaling pathway, a key downstream target of Ubc13.^[7]

- Principle: Cells are engineered to express a reporter gene (e.g., luciferase) under the control of an NF- κ B responsive promoter. Activation of the NF- κ B pathway leads to the expression of the reporter protein.
- Procedure: Cells are treated with NSC697923 at different concentrations, followed by stimulation with an NF- κ B activator (e.g., TNF α or IL-1 β). The activity of the reporter protein is then measured.
- Endpoint: A decrease in reporter gene activity indicates inhibition of the NF- κ B pathway.

Signaling Pathway and Experimental Workflow Diagrams

Visualizing the complex biological processes and experimental setups is essential for a clear understanding. The following diagrams, generated using the DOT language, illustrate the Ubc13 signaling pathway and the workflows of the key experiments.



[Click to download full resolution via product page](#)

Caption: Ubc13-mediated NF- κ B signaling pathway.

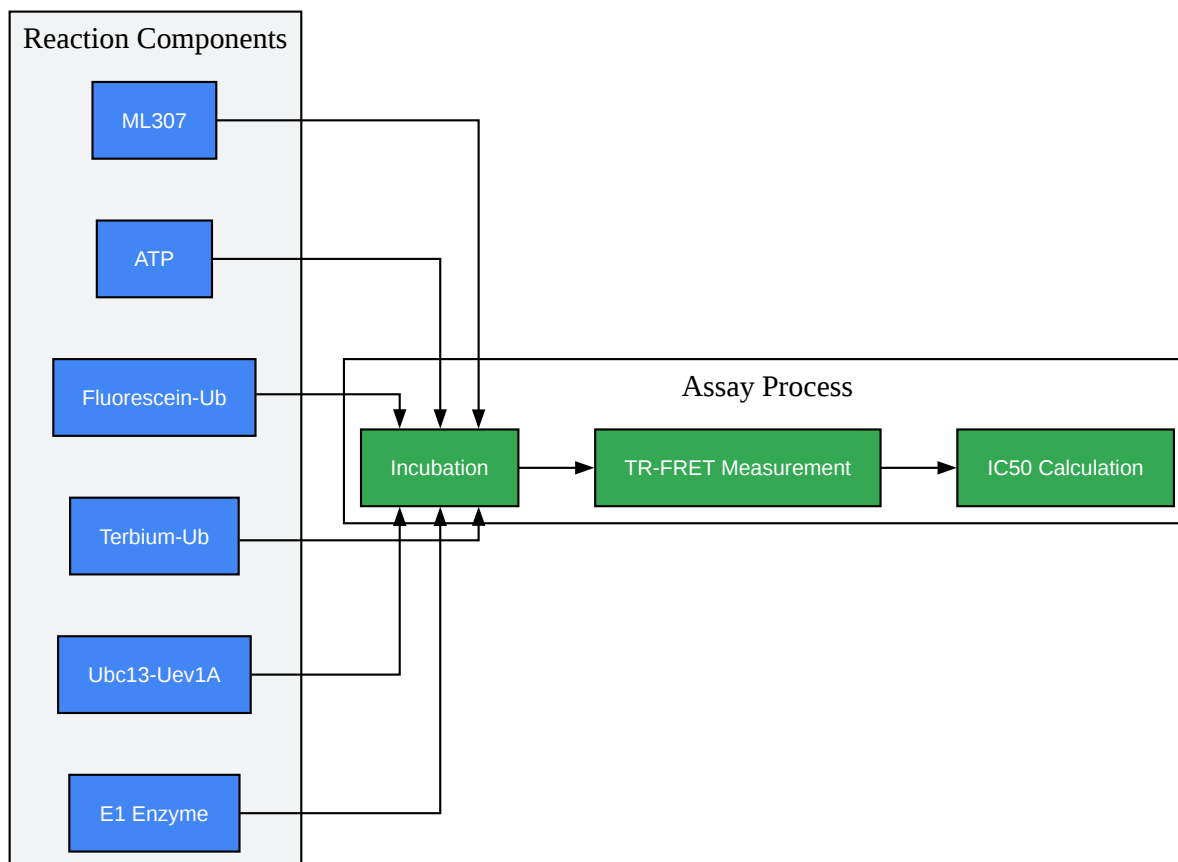

[Click to download full resolution via product page](#)

Caption: TR-FRET assay workflow for **ML307**.

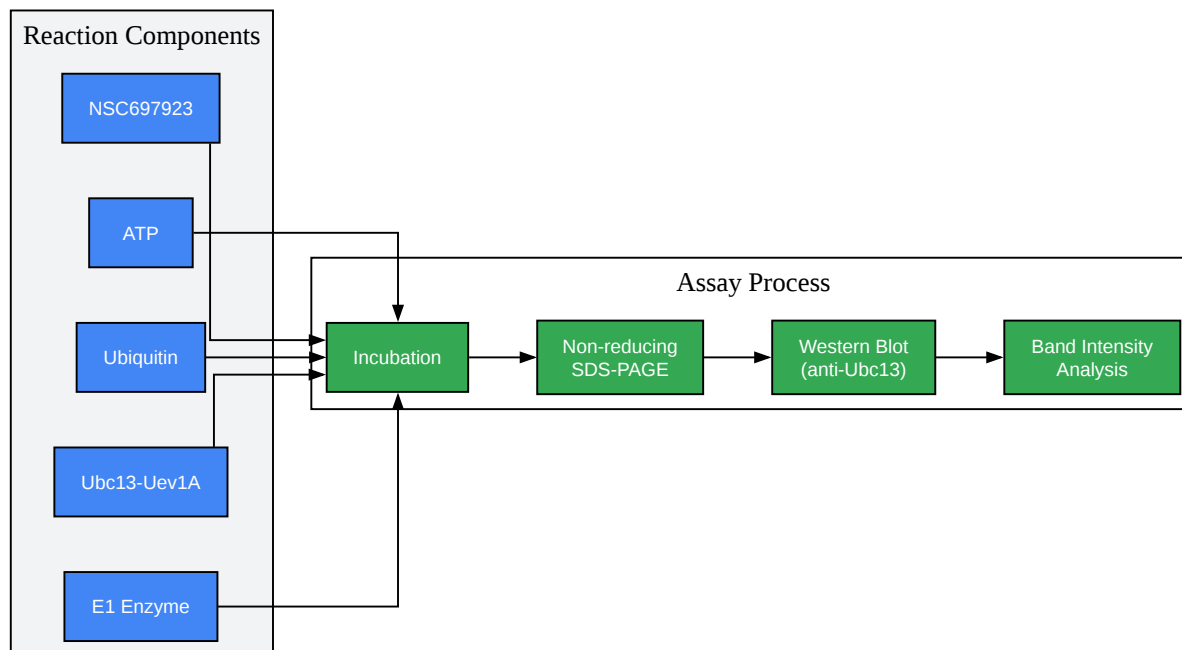

[Click to download full resolution via product page](#)

Caption: In vitro Ubc13~Ub conjugate assay for NSC697923.

Need Custom Synthesis?

BenchChem offers custom synthesis for rare earth carbides and specific isotopic labeling.

Email: info@benchchem.com or [Request Quote Online](#).

References

- 1. [medchemexpress.com](https://www.medchemexpress.com) [medchemexpress.com]
- 2. Ubc13: the Lys63 ubiquitin chain building machine - PMC [pmc.ncbi.nlm.nih.gov]
- 3. NSC-697923 | Cell Signaling Technology [cellsignal.com]

- [4. Selective UBC 13 Inhibitors - Probe Reports from the NIH Molecular Libraries Program - NCBI Bookshelf \[ncbi.nlm.nih.gov\]](#)
- [5. selleckchem.com \[selleckchem.com\]](#)
- [6. Covalent Inhibition of Ubc13 Affects Ubiquitin Signaling and Reveals Active Site Elements Important for Targeting - PubMed \[pubmed.ncbi.nlm.nih.gov\]](#)
- [7. UBC13-Mediated Ubiquitin Signaling Promotes Removal of Blocking Adducts from DNA Double-Strand Breaks - PMC \[pmc.ncbi.nlm.nih.gov\]](#)
- [8. Covalent Inhibition of Ubc13 Affects Ubiquitin Signaling and Reveals Active Site Elements Important for Targeting - PMC \[pmc.ncbi.nlm.nih.gov\]](#)
- [9. researchgate.net \[researchgate.net\]](#)
- To cite this document: BenchChem. [A Comparative Guide to Ubc13 Inhibitors: ML307 vs. NSC697923]. BenchChem, [2026]. [Online PDF]. Available at: [\[https://www.benchchem.com/product/b15136055/docs#a-comparative-guide-to-ubc13-inhibitors-ml307-vs-nsc697923\]](https://www.benchchem.com/product/b15136055/docs#a-comparative-guide-to-ubc13-inhibitors-ml307-vs-nsc697923)

Disclaimer & Data Validity:

The information provided in this document is for Research Use Only (RUO) and is strictly not intended for diagnostic or therapeutic procedures. While BenchChem strives to provide accurate protocols, we make no warranties, express or implied, regarding the fitness of this product for every specific experimental setup.

Technical Support: The protocols provided are for reference purposes. Unsure if this reagent suits your experiment?

Need Industrial/Bulk Grade? [Request Custom Synthesis Quote](#)

BenchChem

Our mission is to be the trusted global source of essential and advanced chemicals, empowering scientists and researchers to drive progress in science and industry.

Contact

Address: 3281 E Guasti Rd

Ontario, CA 91761, United States

Phone: (601) 213-4426

Email: info@benchchem.com

Contact our Ph.D. Support Team for a compatibility check