

# minimizing KMG-301AM TFA cytotoxicity in long-term experiments

**Author:** BenchChem Technical Support Team. **Date:** April 2026

## Compound of Interest

Compound Name: KMG-301AM TFA

Cat. No.: B15135756

[Get Quote](#)

## Technical Support Center: KMG-301AM TFA

Welcome to the technical support center for KMG-301AM. This resource is designed to assist researchers, scientists, and drug development professionals in minimizing potential cytotoxicity associated with KMG-301AM, particularly in long-term experiments. Here you will find troubleshooting guides and frequently asked questions (FAQs) to address specific issues you may encounter.

## Frequently Asked Questions (FAQs)

Q1: What is KMG-301AM and how does it work?

A1: KMG-301AM is a cell-permeable fluorescent probe designed for the selective detection of magnesium ions ( $Mg^{2+}$ ) within mitochondria.<sup>[1][2]</sup> Its acetoxymethyl (AM) ester form allows it to passively diffuse across the plasma and mitochondrial membranes.<sup>[3][4]</sup> Once inside the cell, intracellular esterases cleave the AM group, trapping the active, membrane-impermeable probe (KMG-301) within the mitochondria.<sup>[1][3]</sup> The fluorescence intensity of KMG-301 significantly increases upon binding to  $Mg^{2+}$ , enabling the visualization and quantification of mitochondrial  $Mg^{2+}$  dynamics.<sup>[1]</sup>

Q2: What are the potential sources of cytotoxicity when using KMG-301AM in long-term experiments?

A2: There are two primary potential sources of cytotoxicity associated with KMG-301AM:

- **AM Ester Hydrolysis:** The cleavage of the acetoxymethyl (AM) ester group by intracellular esterases releases formaldehyde and acetic acid as byproducts.[2] At high concentrations or with prolonged incubation times, these byproducts can be toxic to cells.[2]
- **Trifluoroacetic Acid (TFA) Counterion:** KMG-301AM, like many synthetic molecules purified by reverse-phase HPLC, may be supplied as a trifluoroacetate salt.[5][6] Residual TFA in the product can be cytotoxic and may interfere with cellular assays, leading to inconsistent results or unexpected cell death.[7][8]

Q3: What is Trifluoroacetic acid (TFA) and why is it present in the KMG-301AM product?

A3: Trifluoroacetic acid (TFA) is a strong acid commonly used in the synthesis and purification of peptides and other synthetic molecules, including fluorescent probes.[6] It is often used as an ion-pairing agent during reverse-phase high-performance liquid chromatography (RP-HPLC) for purification.[6] As a result, the final lyophilized product can contain TFA as a counterion to the positively charged molecule.[5]

Q4: How can the TFA counterion affect my long-term experiments?

A4: The presence of the TFA counterion can lead to several issues in long-term cell culture experiments:

- **Direct Cytotoxicity:** TFA can be toxic to cells, with the degree of toxicity varying between different cell lines.[6][9]
- **Inhibition of Cell Proliferation:** TFA has been shown to inhibit cell proliferation at higher concentrations.[7]
- **Alteration of Cellular Functions:** TFA can interfere with cellular assays, potentially leading to misleading or inconsistent results.[7][8]

Q5: How can I minimize cytotoxicity from the AM ester group?

A5: To minimize cytotoxicity from the hydrolysis of the AM ester, it is crucial to optimize the loading conditions for your specific cell type and experimental setup. This involves:

- **Titration of the KMG-301AM Concentration:** Determine the lowest effective concentration of the probe that provides a sufficient signal-to-noise ratio.[\[2\]](#)
- **Optimizing Incubation Time:** Minimize the incubation time required for adequate probe loading and de-esterification.[\[4\]](#)
- **Cell Viability Assays:** Perform cell viability assays to determine the optimal probe concentration and loading time that do not adversely affect your cells.[\[2\]](#)

## Troubleshooting Guides

### Problem 1: High Cell Death or Abnormal Morphology Observed in Long-Term Experiments

Possible Cause:

- Cytotoxicity from the KMG-301AM probe (AM ester or TFA counterion).
- High concentration of the DMSO solvent.[\[2\]](#)
- Phototoxicity from excessive exposure to excitation light.[\[10\]](#)

Troubleshooting Workflow

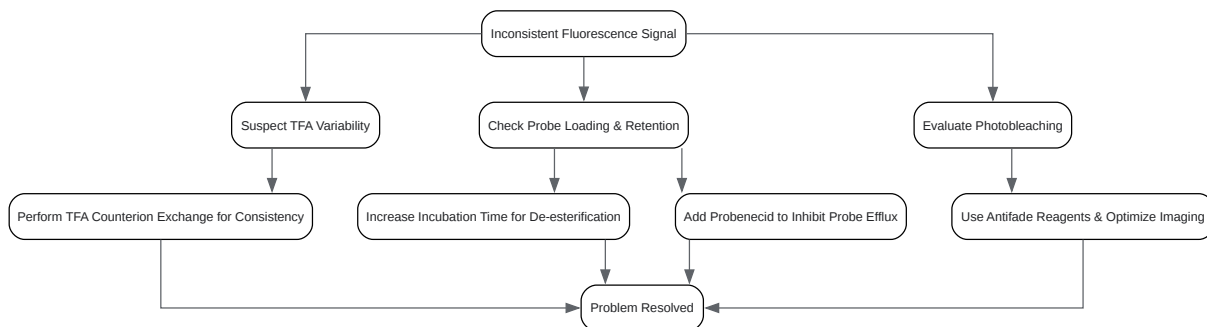
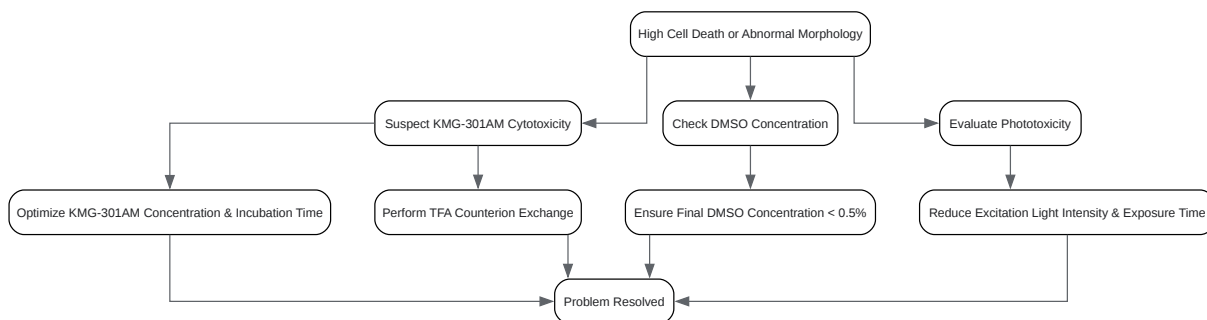

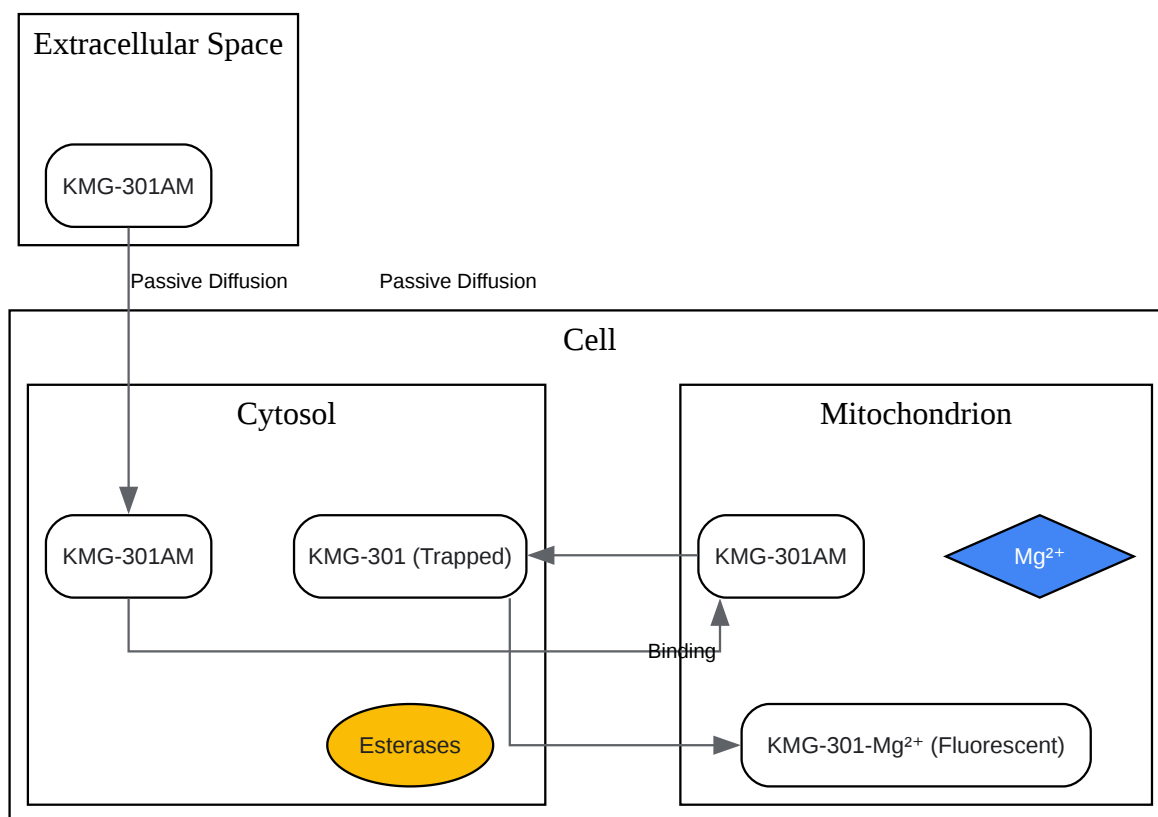

[Click to download full resolution via product page](#)

### Need Custom Synthesis?

BenchChem offers custom synthesis for rare earth carbides and specific isotopic labeling.

Email: [info@benchchem.com](mailto:info@benchchem.com) or [Request Quote Online](#).

## References

- 1. [benchchem.com](https://www.benchchem.com) [benchchem.com]
- 2. [benchchem.com](https://www.benchchem.com) [benchchem.com]
- 3. [benchchem.com](https://www.benchchem.com) [benchchem.com]
- 4. [benchchem.com](https://www.benchchem.com) [benchchem.com]

- [5. Peptide counter ions \[innovagen.com\]](#)
- [6. Counter-ion effect on antistaphylococcal activity and cytotoxicity of selected antimicrobial peptides - PMC \[pmc.ncbi.nlm.nih.gov\]](#)
- [7. benchchem.com \[benchchem.com\]](#)
- [8. benchchem.com \[benchchem.com\]](#)
- [9. benchchem.com \[benchchem.com\]](#)
- [10. benchchem.com \[benchchem.com\]](#)
- To cite this document: BenchChem. [minimizing KMG-301AM TFA cytotoxicity in long-term experiments]. BenchChem, [2026]. [Online PDF]. Available at: [\[https://www.benchchem.com/product/b15135756/docs#minimizing-kmg-301am-tfa-cytotoxicity-in-long-term-experiments\]](https://www.benchchem.com/product/b15135756/docs#minimizing-kmg-301am-tfa-cytotoxicity-in-long-term-experiments)

---

#### Disclaimer & Data Validity:

The information provided in this document is for Research Use Only (RUO) and is strictly not intended for diagnostic or therapeutic procedures. While BenchChem strives to provide accurate protocols, we make no warranties, express or implied, regarding the fitness of this product for every specific experimental setup.

**Technical Support:** The protocols provided are for reference purposes. Unsure if this reagent suits your experiment?

**Need Industrial/Bulk Grade?** [Request Custom Synthesis Quote](#)

## BenchChem

Our mission is to be the trusted global source of essential and advanced chemicals, empowering scientists and researchers to drive progress in science and industry.

#### Contact

Address: 3281 E Guasti Rd

Ontario, CA 91761, United States

Phone: (601) 213-4426

Email: [info@benchchem.com](mailto:info@benchchem.com)

Contact our Ph.D. Support Team for a compatibility check