

Validating Target Engagement of PROTACs: A Comparative Guide

Author: BenchChem Technical Support Team. **Date:** April 2026

Compound of Interest

Compound Name: *E3 Ligase Ligand-linker Conjugate*
45
Cat. No.: *B15135820*

[Get Quote](#)

A critical step in the development of Proteolysis Targeting Chimeras (PROTACs) is the rigorous validation of target engagement. This ensures that the PROTAC molecule effectively binds to its intended protein of interest (POI) and the E3 ligase, initiating the degradation process. This guide provides a comparative overview of key methodologies for validating PROTAC target engagement, offering researchers, scientists, and drug development professionals a comprehensive resource for selecting the most appropriate assays for their research needs.

While specific information on "Conjugate 45-based PROTACs" is not available in the public domain, this guide focuses on established and widely used techniques for validating the target engagement of PROTACs in general. The principles and methods described herein are applicable to a broad range of PROTAC molecules.

Comparative Analysis of Target Engagement Assays

The selection of an appropriate assay for validating PROTAC target engagement depends on various factors, including the specific research question, the available resources, and the desired throughput. The following table summarizes key quantitative parameters for commonly used methods.

Assay	Principle	Key Parameters & Typical Values	Throughput	Advantages	Limitations
NanoBRET™ Target Engagement Assay	Bioluminescence Resonance Energy Transfer (BRET) between a NanoLuc® luciferase-tagged target protein and a fluorescently labeled tracer that competes with the PROTAC.	IC50/EC50: Varies depending on the PROTAC and target, typically in the nM to μM range.	High	Live-cell measurements, provides quantitative binding affinity in a physiological context.	Requires genetic engineering of the target protein, potential for steric hindrance from the tag.
Fluorescence Polarization (FP) Assay	Measures the change in polarization of fluorescently labeled ligands upon binding to the target protein. PROTACs compete with the fluorescent ligand.	Ki/IC50: Highly dependent on the affinity of the tracer and PROTAC, typically nM to μM.	High	In vitro, homogenous assay, suitable for high-throughput screening.	Requires a suitable fluorescent probe, susceptible to interference from fluorescent compounds.

<p>Isothermal Titration Calorimetry (ITC)</p>	<p>Measures the heat change upon binding of the PROTAC to the target protein and E3 ligase, allowing for the determination of binding affinity, stoichiometry, and thermodynamics.</p>	<p>Kd: Can measure a wide range of affinities from mM to nM.</p>	<p>Low</p>	<p>Label-free, provides a complete thermodynamic profile of the interaction.</p>	<p>Requires large amounts of pure protein, low throughput.</p>
<p>Surface Plasmon Resonance (SPR)</p>	<p>Measures the change in refractive index at the surface of a sensor chip when the PROTAC binds to the immobilized target protein or E3 ligase.</p>	<p>Kd, kon, koff: Provides kinetic and affinity data.</p>	<p>Medium</p>	<p>Real-time analysis of binding kinetics, label-free.</p>	<p>Requires immobilization of one binding partner, which may affect its conformation and activity.</p>
<p>Cellular Thermal Shift Assay (CETSA)</p>	<p>Based on the principle that ligand binding stabilizes the target protein against</p>	<p>Shift in Tagg: The magnitude of the temperature shift indicates</p>	<p>Medium</p>	<p>In-cell and in-tissue target engagement confirmation, label-free.</p>	<p>Indirect measure of binding, not all proteins show a clear thermal shift.</p>

	thermal denaturation.	target engagement.			
Mass Spectrometry (MS)-based Proteomics	Quantifies the abundance of the target protein and other proteins in the cell after PROTAC treatment.	DC50/Dmax: Concentration for 50% degradation and maximal degradation level.	Low to Medium	Unbiased, global view of protein degradation, identifies off-targets.	Technically complex, lower throughput than biochemical assays.

Experimental Protocols

Detailed methodologies for the key experiments are provided below to guide researchers in their experimental design.

NanoBRET™ Target Engagement Assay Protocol

- **Cell Line Preparation:** Co-transfect cells with a plasmid encoding the NanoLuc®-tagged protein of interest and a plasmid for a fluorescent cell-permeable tracer specific for the target protein. Alternatively, stable cell lines can be generated.
- **Cell Plating:** Seed the transfected cells into a 96- or 384-well white-bottom plate at an appropriate density and incubate overnight.
- **Compound Treatment:** Add serial dilutions of the PROTAC or control compounds to the cells.
- **Tracer Addition:** Add the fluorescent tracer to all wells.
- **Signal Detection:** After a defined incubation period, add the NanoBRET™ substrate and measure both the donor (NanoLuc®) and acceptor (tracer) emission signals using a plate reader equipped for BRET measurements.
- **Data Analysis:** Calculate the BRET ratio (acceptor emission/donor emission) and plot it against the compound concentration to determine the IC50 value.

Fluorescence Polarization (FP) Assay Protocol

- **Reagent Preparation:** Prepare a solution of the purified target protein, a fluorescently labeled ligand (tracer) that binds to the target, and the PROTAC compounds at various concentrations.
- **Assay Plate Setup:** In a black microplate, add the target protein and the fluorescent tracer to all wells.
- **Compound Addition:** Add serial dilutions of the PROTAC or control compounds to the wells.
- **Incubation:** Incubate the plate at room temperature for a specified period to allow the binding reaction to reach equilibrium.
- **Measurement:** Measure the fluorescence polarization of each well using a plate reader equipped with polarization filters.
- **Data Analysis:** Plot the change in fluorescence polarization against the PROTAC concentration to determine the IC₅₀ or K_i value.

Mass Spectrometry (MS)-based Proteomics Protocol

- **Cell Culture and Treatment:** Culture cells to the desired confluency and treat with various concentrations of the PROTAC for a specific duration.
- **Cell Lysis and Protein Extraction:** Harvest the cells, lyse them, and extract the total protein.
- **Protein Digestion:** Digest the proteins into peptides using an enzyme such as trypsin.
- **Peptide Labeling (Optional):** For quantitative proteomics, peptides can be labeled with isobaric tags (e.g., TMT or iTRAQ).
- **LC-MS/MS Analysis:** Separate the peptides by liquid chromatography and analyze them by tandem mass spectrometry to identify and quantify the proteins.
- **Data Analysis:** Use specialized software to analyze the MS data, identify the proteins, and quantify the changes in protein abundance upon PROTAC treatment. This will determine the DC₅₀ and D_{max} values for the target protein and assess off-target degradation.

Visualizing PROTAC Mechanisms and Workflows

Diagrams created using Graphviz (DOT language) are provided below to illustrate key concepts in PROTAC target engagement.

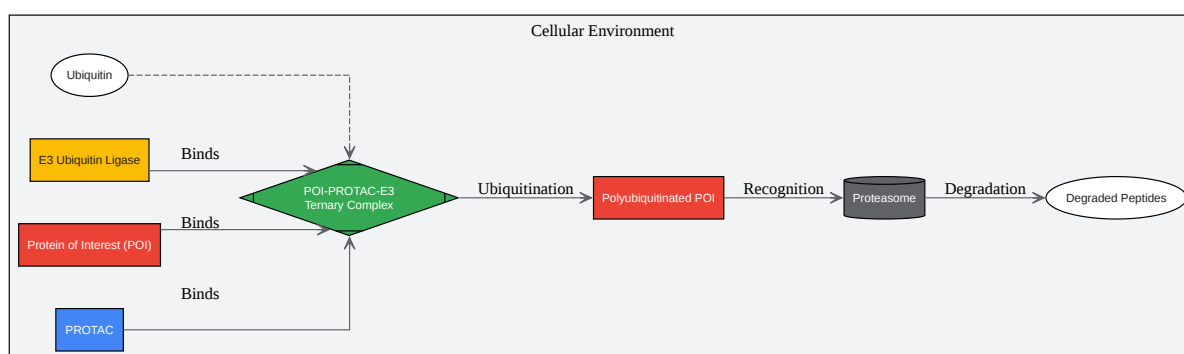

[Click to download full resolution via product page](#)

Caption: Mechanism of Action for a PROTAC molecule.

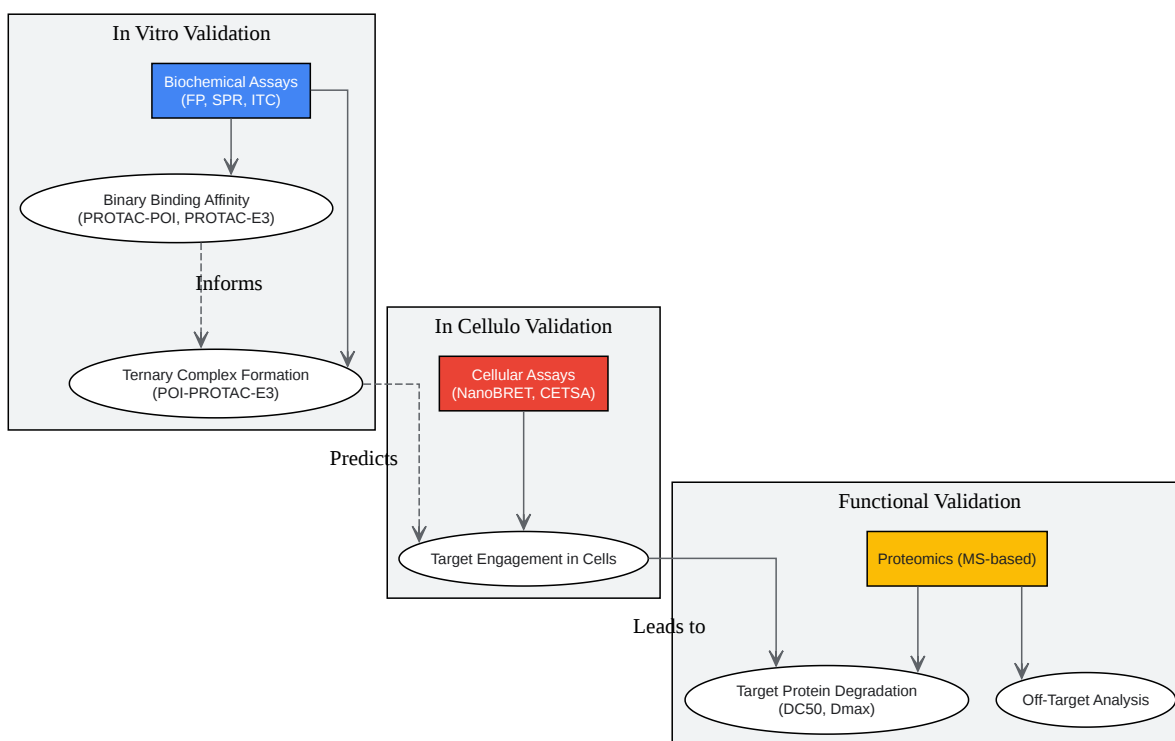

[Click to download full resolution via product page](#)

Caption: Experimental workflow for validating PROTAC target engagement.

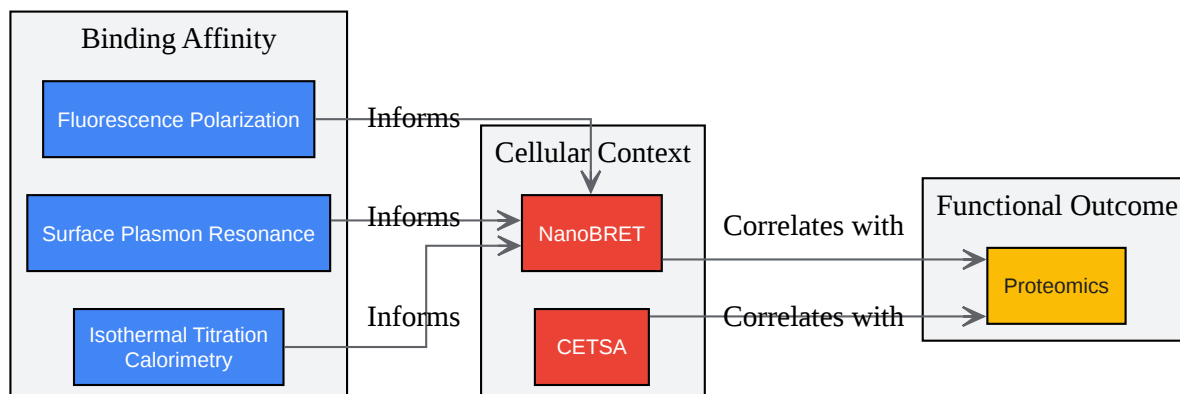

[Click to download full resolution via product page](#)

Caption: Logical relationship between different target engagement assays.

- To cite this document: BenchChem. [Validating Target Engagement of PROTACs: A Comparative Guide]. BenchChem, [2026]. [Online PDF]. Available at: [\[https://www.benchchem.com/product/b15135820/docs#validating-target-engagement-of-protacs-a-comparative-guide\]](https://www.benchchem.com/product/b15135820/docs#validating-target-engagement-of-protacs-a-comparative-guide)

Disclaimer & Data Validity:

The information provided in this document is for Research Use Only (RUO) and is strictly not intended for diagnostic or therapeutic procedures. While BenchChem strives to provide accurate protocols, we make no warranties, express or implied, regarding the fitness of this product for every specific experimental setup.

Technical Support: The protocols provided are for reference purposes. Unsure if this reagent suits your experiment?

Need Industrial/Bulk Grade? [Request Custom Synthesis Quote](#)

BenchChem

Our mission is to be the trusted global source of essential and advanced chemicals, empowering scientists and researchers to drive progress in science and industry.

Contact

Address: 3281 E Guasti Rd

Ontario, CA 91761, United States

Phone: (601) 213-4426

Email: info@benchchem.com

[Contact our Ph.D. Support Team for a compatibility check](#)