

Technical Support Center: Troubleshooting Data Logging Gaps and Errors

Author: BenchChem Technical Support Team. **Date:** April 2026

Compound of Interest

Compound Name: CW0134
Cat. No.: B15135559

[Get Quote](#)

Disclaimer: The following troubleshooting guide and FAQs are intended for general-purpose laboratory and industrial data loggers, including those used for temperature and humidity monitoring. The model "CW0134" was not specifically identified in public documentation, so this guide addresses common issues encountered with similar devices.

This technical support center provides troubleshooting guidance and answers to frequently asked questions for researchers, scientists, and drug development professionals experiencing data logging gaps and errors during their experiments.

Troubleshooting Guides

This section provides step-by-step instructions in a question-and-answer format to resolve specific data logging issues.

Question: Why are there gaps in my logged data?

Answer: Gaps in logged data can occur for several reasons. Follow these steps to diagnose and resolve the issue.

- Check Power and Battery:

- Is the data logger powered on?
- If battery-powered, is the battery low or depleted? Low battery levels can interrupt data logger operation, leading to data gaps.[1][2]
- For rechargeable models, ensure the battery is fully charged.
- Verify Connectivity:
 - If using a logger with a removable probe or sensor, ensure the connection is secure. Loose or damaged wires can cause signal inconsistencies.[2]
 - For wireless data loggers, check the network connection. Network failure can lead to missed data transmission.[3]
- Review Logging Configuration:
 - Logging Interval: A logging interval that is too long may miss short-term fluctuations, appearing as gaps in data if an event occurs between measurements.[3][4] Consider if the set interval is appropriate for the experiment.
 - Memory Capacity: Data loggers have limited memory. If the memory is full, the logger may stop recording. Regularly download and back up data to prevent loss.[3][5]
- Environmental Factors:
 - Electromagnetic Interference: Placing the data logger near strong electromagnetic sources can interfere with signal transmission and accuracy.[2]
 - Physical Obstructions: Ensure there are no physical barriers blocking the signal for wireless loggers.

Question: Why are my data readings inaccurate or inconsistent?

Answer: Inaccurate data can compromise your experimental results. Use this checklist to identify the cause.

- Sensor Placement and Environment:

- Proper Location: Ensure the sensor is placed in a location that accurately represents the environment you want to measure. Avoid placing it in direct sunlight, near heating or cooling sources, or in areas with poor air circulation.[\[6\]](#)[\[7\]](#)
- Equilibration Time: When moving a data logger to a new environment, allow sufficient time for the sensor to equilibrate to the new conditions before starting to log data. This can take anywhere from a few minutes to half an hour.[\[8\]](#)
- Sensor Contamination: Dust, dirt, or moisture on the sensor can lead to inaccurate readings.[\[9\]](#)
- Calibration:
 - Regular Calibration: Data logger sensors can drift over time, leading to decreased accuracy. Regular calibration against a known standard is crucial.[\[1\]](#)[\[10\]](#)[\[11\]](#)
 - Calibration Certificate: Ensure your data logger has a valid calibration certificate, especially when used in regulated environments.
- Software and Firmware:
 - Up-to-date Software: Ensure you are using the latest version of the data logger's software and firmware. Updates often include bug fixes that can improve performance.[\[2\]](#)[\[12\]](#)

Frequently Asked Questions (FAQs)

Q1: What should I do if my data logger is not detected by my computer?

A1: First, ensure that the correct drivers for your data logger are installed on your computer. You may also need administrative rights to install the software and drivers correctly. Check that any antivirus or firewall software is not blocking the program. If the issue persists, try a different USB port or cable.[\[12\]](#)

Q2: How often should I calibrate my data logger?

A2: The frequency of calibration depends on the manufacturer's recommendations, the environmental conditions of use, and internal quality requirements. A general guideline is to calibrate at least once a year.[\[11\]](#)

Q3: Can I use my data logger in extreme environments?

A3: Check the manufacturer's specifications for the operating range of your data logger. Exposing it to temperatures, humidity, or pressures outside of its specified range can damage the device and lead to inaccurate readings.[\[13\]](#)

Q4: What is the difference between accuracy and resolution in a data logger?

A4: Accuracy refers to how close the measured value is to the true value. Resolution is the smallest change in the measured value that the data logger can detect and display. A high-resolution logger is not necessarily a high-accuracy logger.

Data Logging Troubleshooting Log

To aid in diagnosing recurring issues, use the following table to log any problems and the steps taken to resolve them.

Date	Data Logger ID	Issue Observed (Gaps, Inaccurate Data, etc.)	Troubleshooting Steps Taken	Resolution
------	----------------	--	-----------------------------	------------

Experimental Protocol: Data Logger Performance Validation

This protocol outlines a general procedure to validate the performance of a temperature and humidity data logger.

Objective: To verify the accuracy and reliability of the data logger against a calibrated reference instrument.

Materials:

- Data logger to be validated

- Calibrated reference thermometer and hygrometer
- Controlled environment chamber or a stable, well-insulated container
- Data logging software

Methodology:

- Setup:
 - Place the data logger and the reference instruments in the controlled environment chamber.
 - Position the sensors of all devices as close to each other as possible to ensure they are measuring the same environment.
- Configuration:
 - Set the data logger to record at a specific interval (e.g., every 1 minute).
 - Begin recording data from both the data logger and the reference instruments simultaneously.
- Data Collection:
 - Allow the instruments to log data for a predetermined period, ensuring the environment covers a range of expected experimental conditions (e.g., varying temperature and humidity levels).
- Data Analysis:
 - Download the data from the data logger.
 - Compare the data logger's readings to the readings from the reference instruments at corresponding timestamps.
 - Calculate the difference (error) between the data logger and the reference instrument for each data point.

- Determine if the error is within the manufacturer's specified accuracy for the data logger.

Visualizations

The following diagrams illustrate common troubleshooting and validation workflows.

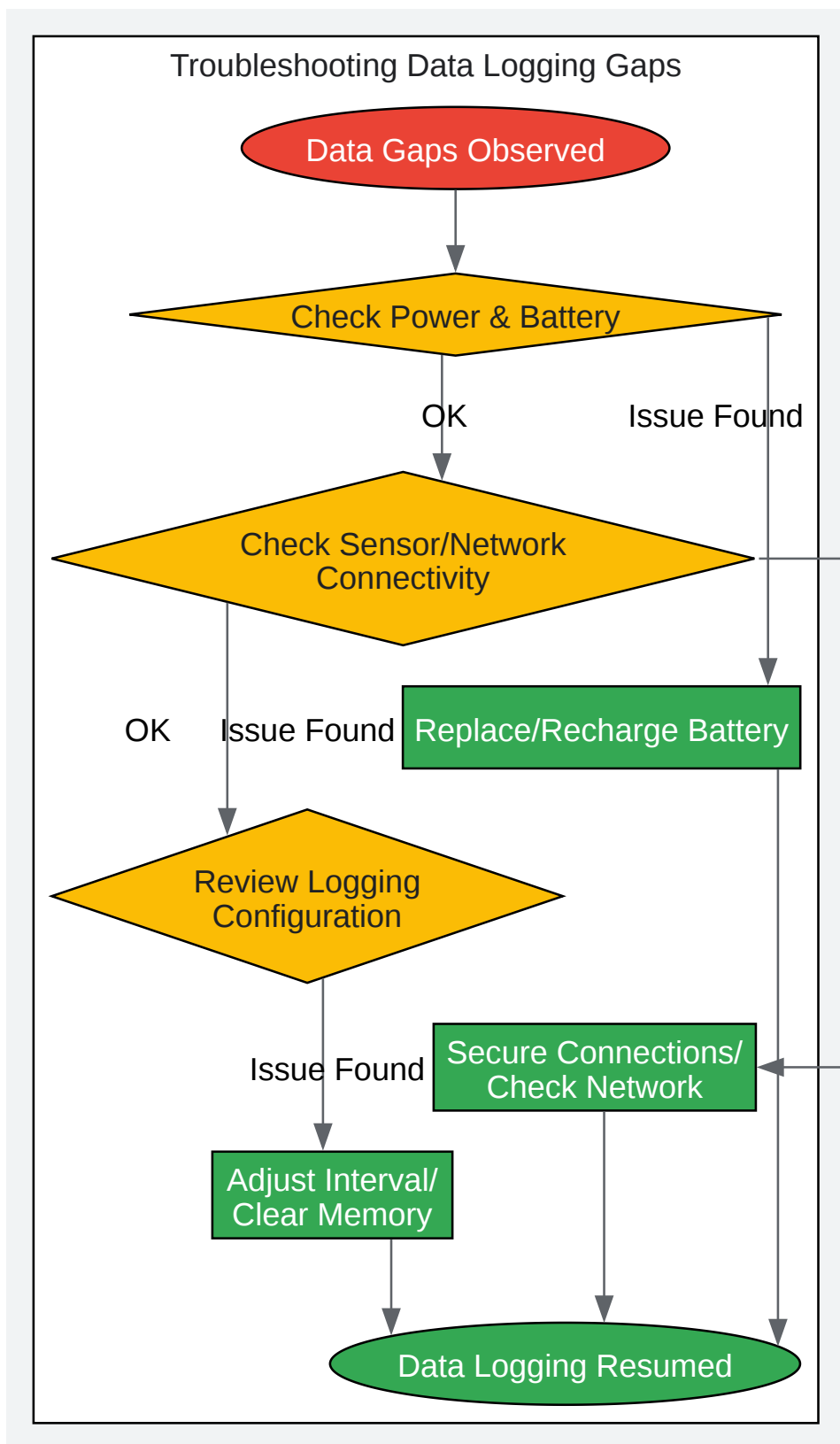

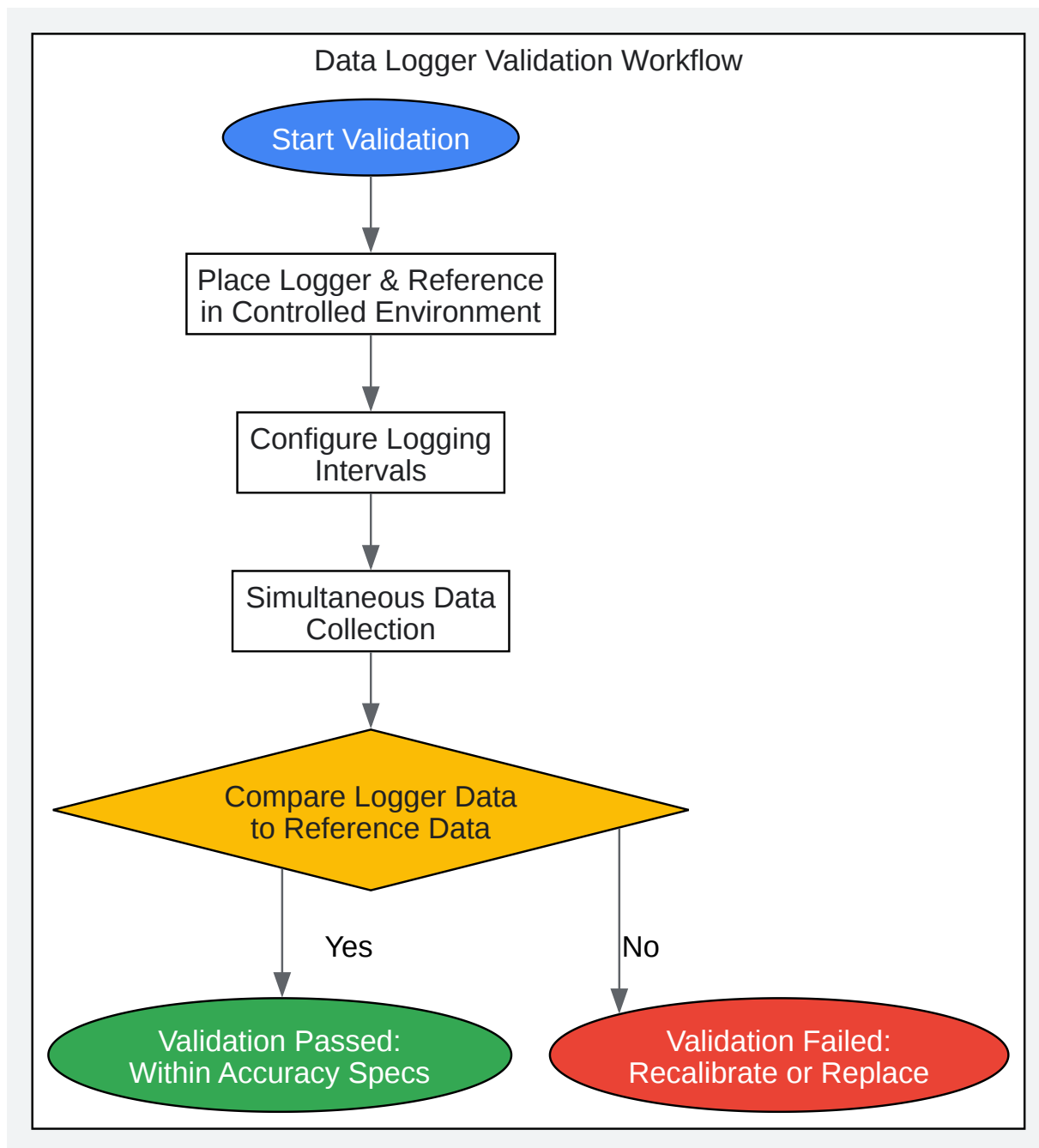

[Click to download full resolution via product page](#)

Need Custom Synthesis?

BenchChem offers custom synthesis for rare earth carbides and specific isotopic labeling.

Email: info@benchchem.com or [Request Quote Online](#).

References

- [1. Cold Chain Data Loggers. Top 5 common usage mistakes. \[mettcover.com\]](#)
- [2. valuetronics.com \[valuetronics.com\]](#)
- [3. 7 Common Problems with Data Loggers - and How Data Acquisition Solves Them — XiltriX \[xiltrixusa.com\]](#)
- [4. gtek-india.com \[gtek-india.com\]](#)
- [5. thermoline.com.au \[thermoline.com.au\]](#)
- [6. Common humidity measurement problems and how to avoid them | Vaisala \[vaisala.com\]](#)
- [7. tzonetemperature.com \[tzonetemperature.com\]](#)
- [8. DP3: Digital Print Preservation Portal | He said, She said: Discrepancies in T and RH Readings \[dp3project.org\]](#)
- [9. 6-Reasons Temperature and Humidity Transmitter Fails and Solutions You Must Know - HENGKOMeter \[hengkometer.com\]](#)
- [10. madgetech.com \[madgetech.com\]](#)
- [11. conserv.io \[conserv.io\]](#)
- [12. help.thermoworks.com \[help.thermoworks.com\]](#)
- [13. Guía para registradores de datos de temperatura | tempmate.® \[tempmate.com\]](#)
- [To cite this document: BenchChem. \[Technical Support Center: Troubleshooting Data Logging Gaps and Errors\]. BenchChem, \[2026\]. \[Online PDF\]. Available at: \[https://www.benchchem.com/product/b15135559/docs#technical-support-center-troubleshooting-data-logging-gaps-and-errors\]](#)

Disclaimer & Data Validity:

The information provided in this document is for Research Use Only (RUO) and is strictly not intended for diagnostic or therapeutic procedures. While BenchChem strives to provide accurate protocols, we make no warranties, express or implied, regarding the fitness of this product for every specific experimental setup.

Technical Support: The protocols provided are for reference purposes. Unsure if this reagent suits your experiment?

Need Industrial/Bulk Grade? [Request Custom Synthesis Quote](#)

BenchChem

Our mission is to be the trusted global source of essential and advanced chemicals, empowering scientists and researchers to drive progress in science and industry.

Contact

Address: 3281 E Guasti Rd
Ontario, CA 91761, United States
Phone: (601) 213-4426
Email: info@benchchem.com

[Contact our Ph.D. Support Team for a compatibility check](#)