

Technical Support Center: Optimizing Chromatographic Separation of Entrectinib and its Metabolites

Author: BenchChem Technical Support Team. **Date:** April 2026

Compound of Interest

Compound Name: *Entrectinib-d8*

Cat. No.: *B15135475*

[Get Quote](#)

Welcome to the technical support center for the chromatographic analysis of entrectinib and its metabolites. This resource is designed for researchers, scientists, and drug development professionals to provide troubleshooting guidance and answers to frequently asked questions (FAQs) encountered during experimental procedures.

Frequently Asked Questions (FAQs) & Troubleshooting Guide

This section addresses specific issues you may encounter during the chromatographic separation of entrectinib and its metabolites.

Issue 1: Poor Peak Shape (Tailing or Fronting) for Entrectinib or its Metabolites

- Question: My chromatogram shows significant peak tailing for entrectinib and its primary metabolite, M5. What are the potential causes and solutions?
- Answer: Peak tailing is a common issue in reverse-phase chromatography, often caused by secondary interactions between the analyte and the stationary phase. Here's a step-by-step

troubleshooting guide:

- Check Mobile Phase pH: Entrectinib is a basic compound. A mobile phase with a pH that is not optimal can lead to peak tailing. Ensure the mobile phase pH is appropriate for the column chemistry. For C18 columns, using a mobile phase containing a small percentage of formic acid (e.g., 0.1%) can help to protonate the analytes and reduce tailing.
- Column Contamination: Residual sample components or precipitated salts on the column can cause peak distortion.
 - Solution: Flush the column with a strong solvent wash sequence. For a C18 column, this could be a gradient of water, methanol, acetonitrile, and isopropanol. Always filter your samples and mobile phases to prevent particulate matter from clogging the column.
- Column Void or Channeling: A void at the column inlet or channeling in the packed bed can lead to poor peak shape.
 - Solution: This often indicates the end of the column's life. Replace the column. To prevent this, operate the column within the manufacturer's recommended pressure and pH ranges.
- Sample Overload: Injecting too concentrated a sample can lead to peak fronting.
 - Solution: Dilute your sample and reinject.

Issue 2: Inconsistent Retention Times

- Question: I am observing a drift in retention times for entrectinib and M5 across my injection sequence. What could be the cause?
- Answer: Fluctuating retention times can compromise the reliability of your results. Consider the following:
 - Mobile Phase Composition: Inaccurate mixing of mobile phase components or evaporation of the more volatile solvent can lead to a change in elution strength.

- Solution: Prepare fresh mobile phase daily and ensure the solvent bottles are properly sealed. If using a gradient, ensure the pump is functioning correctly and the solvent lines are primed.
- Column Temperature: Variations in ambient temperature can affect retention times.
 - Solution: Use a column oven to maintain a consistent temperature throughout the analytical run.
- Column Equilibration: Insufficient column equilibration between injections, especially after a gradient, can cause retention time shifts.
 - Solution: Ensure an adequate equilibration time is included at the end of your gradient method. This is typically 5-10 column volumes.

Issue 3: Low Signal Intensity or Poor Sensitivity

- Question: I am struggling to achieve the desired sensitivity for the metabolites of entrectinib, which are present at much lower concentrations than the parent drug. How can I improve my signal intensity?
- Answer: Low sensitivity can be a significant hurdle, especially for low-abundance metabolites. Here are some optimization strategies:
 - Mass Spectrometer Parameters: Optimize the electrospray ionization (ESI) source parameters (e.g., capillary voltage, gas flow, and temperature) and the collision energy for each specific metabolite to maximize the signal.
 - Sample Preparation: A robust sample preparation method is crucial for removing interfering matrix components and concentrating the analytes.
 - Solution: Consider using solid-phase extraction (SPE) instead of a simple protein precipitation, as it can provide a cleaner extract and allow for sample concentration.
 - Mobile Phase Additives: The choice of mobile phase additive can significantly impact ionization efficiency.

- Solution: While formic acid is common, experimenting with other additives like ammonium formate or ammonium acetate might improve the signal for certain metabolites.
- Injection Volume: Increasing the injection volume can increase the signal, but be mindful of potential peak broadening and matrix effects.

Issue 4: Matrix Effects in Plasma Samples

- Question: I suspect matrix effects are impacting the accuracy of my quantification in plasma samples. How can I identify and mitigate this?
- Answer: Matrix effects, where co-eluting endogenous components suppress or enhance the ionization of the analyte, are a common challenge in bioanalysis.
 - Identification: The post-column infusion method is a reliable way to identify regions in the chromatogram where matrix effects occur.
 - Mitigation Strategies:
 - Improve Sample Cleanup: As mentioned before, a more rigorous sample preparation technique like SPE can significantly reduce matrix effects.
 - Chromatographic Separation: Modify your gradient to better separate the analytes from the interfering matrix components.
 - Use a Stable Isotope-Labeled Internal Standard (SIL-IS): A SIL-IS that co-elutes with the analyte is the most effective way to compensate for matrix effects, as it will be affected in the same way as the analyte. D4-entrectinib is a suitable internal standard for entrectinib.^[1]

Experimental Protocols

Below are detailed methodologies for the chromatographic separation of entrectinib and its metabolites, based on published literature.

Method 1: UPLC-MS/MS for Entrectinib and M5 in Human Plasma

This method is adapted from validated bioanalytical procedures and is suitable for pharmacokinetic studies.

- Sample Preparation (Protein Precipitation):
 - To 100 μ L of human plasma, add 20 μ L of internal standard working solution (e.g., D4-entrectinib in methanol).
 - Add 400 μ L of acetonitrile to precipitate the proteins.
 - Vortex for 1 minute.
 - Centrifuge at 13,000 rpm for 10 minutes.
 - Transfer the supernatant to a clean tube and evaporate to dryness under a gentle stream of nitrogen at 40°C.
 - Reconstitute the residue in 100 μ L of the mobile phase.
 - Inject into the UPLC-MS/MS system.
- Chromatographic Conditions:
 - Column: Waters ACQUITY UPLC BEH C18 (2.1 x 50 mm, 1.7 μ m)
 - Mobile Phase A: 0.1% Formic acid in water
 - Mobile Phase B: Acetonitrile
 - Gradient: A typical gradient would start at a low percentage of B, ramp up to a high percentage to elute the analytes, and then return to initial conditions for re-equilibration.
 - Flow Rate: 0.4 mL/min
 - Column Temperature: 40°C
 - Injection Volume: 5 μ L
- Mass Spectrometry Conditions (Triple Quadrupole):

- Ionization Mode: Electrospray Ionization (ESI), Positive
- Multiple Reaction Monitoring (MRM) Transitions:
 - Entrectinib: 561.3 > 475.2
 - M5 (N-dealkylated metabolite): 475.2 > 374.2
 - D4-Entrectinib (IS): 565.3 > 479.2

Method 2: HPLC-MS/MS for Entrectinib in Rat Plasma

This method is suitable for preclinical studies.[\[1\]](#)

- Sample Preparation (Liquid-Liquid Extraction):
 - To 50 μ L of rat plasma, add 10 μ L of internal standard (D4-entrectinib).
 - Add 50 μ L of 1M NaOH.
 - Add 1 mL of methyl tert-butyl ether (MTBE).
 - Vortex for 5 minutes.
 - Centrifuge at 10,000 rpm for 5 minutes.
 - Transfer the organic layer to a new tube and evaporate to dryness.
 - Reconstitute in 200 μ L of mobile phase.
- Chromatographic Conditions:
 - Column: Luna C18 (250 x 4.6 mm, 5 μ m)[\[1\]](#)
 - Mobile Phase: 0.1% Formic acid and Acetonitrile (70:30 v/v)[\[1\]](#)
 - Flow Rate: 1.0 mL/min[\[1\]](#)
 - Detection: UV at 294 nm or MS/MS

- Mass Spectrometry Conditions:
 - MRM Transitions:
 - Entrectinib: 560.6 > 475.1
 - D4-Entrectinib (IS): 580.6 > 496.3

Data Presentation

Table 1: UPLC-MS/MS Parameters for Entrectinib and its Major Metabolite M5

| Analyte | Precursor Ion (m/z) | Product Ion (m/z) | Collision Energy (eV) |
|---------------------|---------------------|-------------------|-----------------------|
| Entrectinib | 561.3 | 475.2 | 35 |
| M5 | 475.2 | 374.2 | 40 |
| D4-Entrectinib (IS) | 565.3 | 479.2 | 35 |

Table 2: HPLC Method Validation Parameters for Entrectinib in Rat Plasma

| Parameter | Result |
|----------------------------------|----------------|
| Linearity Range | 1–20 ng/mL |
| Regression Coefficient (r^2) | 0.999 |
| Retention Time | 5.225 min |
| Internal Standard | D4-Entrectinib |

Visualizations

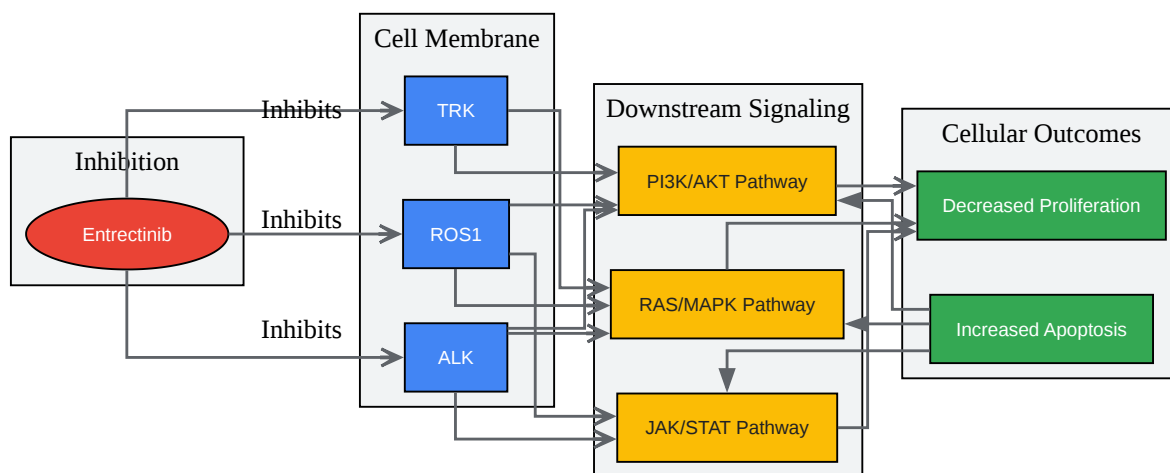

[Click to download full resolution via product page](#)

Caption: Entrectinib signaling pathway inhibition.

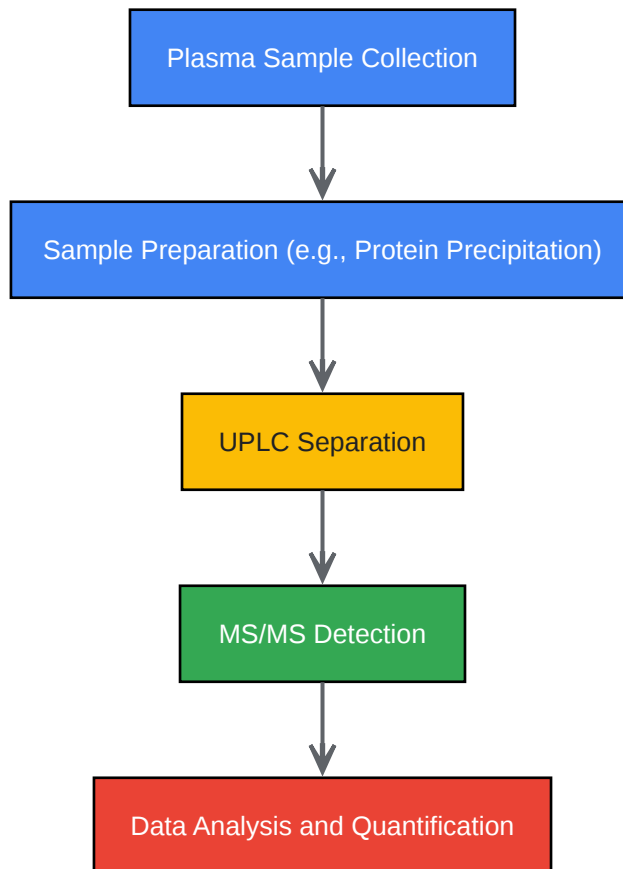

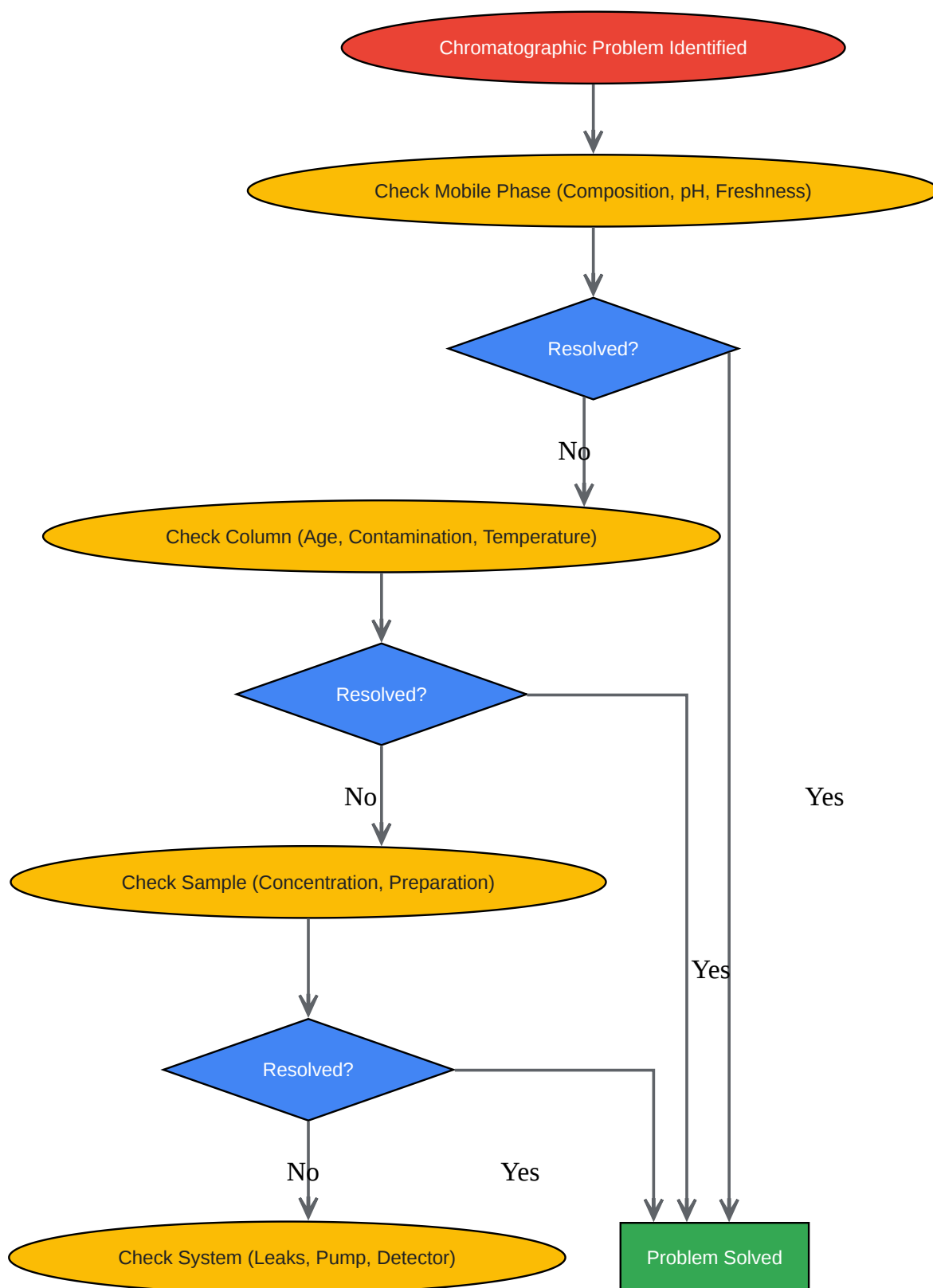

[Click to download full resolution via product page](#)

Need Custom Synthesis?

BenchChem offers custom synthesis for rare earth carbides and specific isotopic labeling.

Email: info@benchchem.com or [Request Quote Online](#).

References

- [1. researchgate.net \[researchgate.net\]](https://www.researchgate.net)
- To cite this document: BenchChem. [Technical Support Center: Optimizing Chromatographic Separation of Entrectinib and its Metabolites]. BenchChem, [2026]. [Online PDF]. Available at: [<https://www.benchchem.com/product/b15135475/docs#technical-support-center-optimizing-chromatographic-separation-of-entrectinib-and-its-metabolites>]

Disclaimer & Data Validity:

The information provided in this document is for Research Use Only (RUO) and is strictly not intended for diagnostic or therapeutic procedures. While BenchChem strives to provide accurate protocols, we make no warranties, express or implied, regarding the fitness of this product for every specific experimental setup.

Technical Support: The protocols provided are for reference purposes. Unsure if this reagent suits your experiment?

Need Industrial/Bulk Grade? [Request Custom Synthesis Quote](#)

BenchChem

Our mission is to be the trusted global source of essential and advanced chemicals, empowering scientists and researchers to drive progress in science and industry.

Contact

Address: 3281 E Guasti Rd
Ontario, CA 91761, United States
Phone: (601) 213-4426
Email: info@benchchem.com

Contact our Ph.D. Support Team for a compatibility check