

Navigating Preclinical Research on LFS-1107: A Technical Support Guide

Author: BenchChem Technical Support Team. **Date:** April 2026

Compound of Interest

Compound Name: LFS-1107
Cat. No.: B15135996

[Get Quote](#)

This technical support center provides researchers, scientists, and drug development professionals with a comprehensive guide to common pitfalls and troubleshooting strategies in preclinical research involving **LFS-1107**, a novel inhibitor of the hypothetical MEK/ERK signaling pathway. By anticipating and addressing potential challenges, this resource aims to enhance the reproducibility and reliability of experimental outcomes.

Frequently Asked Questions (FAQs)

Q1: What is the proposed mechanism of action for **LFS-1107**?

A1: **LFS-1107** is a potent and selective small molecule inhibitor of MEK1 and MEK2 kinases. By binding to the allosteric pocket of MEK, **LFS-1107** prevents the phosphorylation and subsequent activation of ERK1/2. This blockade of the canonical MAPK/ERK signaling pathway is intended to inhibit cell proliferation and induce apoptosis in cancer cells with activating mutations in upstream components like BRAF or RAS.

Q2: What are the recommended in vitro cell lines for testing **LFS-1107** efficacy?

A2: We recommend using cell lines with known BRAF V600E or KRAS G12C/D mutations, as they are predicted to be highly sensitive to MEK inhibition. Examples include A375 (melanoma,

BRAF V600E) and HCT116 (colorectal cancer, KRAS G13D). It is also crucial to include a wild-type cell line (e.g., MCF7) as a negative control to assess selectivity.

Q3: How should I prepare **LFS-1107** for in vitro and in vivo studies?

A3: For in vitro assays, **LFS-1107** should be dissolved in 100% DMSO to create a high-concentration stock solution (e.g., 10 mM). Subsequent dilutions for cell culture treatment should be made in the appropriate culture medium, ensuring the final DMSO concentration does not exceed 0.1% to avoid solvent-induced toxicity. For in vivo studies, a formulation in a vehicle such as 0.5% methylcellulose with 0.2% Tween 80 in sterile water is recommended for oral gavage.

Troubleshooting Guide

In Vitro Assays

Problem 1: High variability in cell viability assay results.

- Possible Cause 1: Inconsistent cell seeding. Uneven cell numbers across wells can lead to significant differences in metabolic activity or confluence, affecting the final readout.
 - Solution: Ensure thorough cell suspension mixing before and during plating. Use a multichannel pipette for seeding and visually inspect plates for even cell distribution.
- Possible Cause 2: Edge effects in multi-well plates. Wells on the perimeter of the plate are prone to evaporation, leading to altered media concentration and cell stress.
 - Solution: Avoid using the outer wells of the plate for experimental conditions. Fill these wells with sterile PBS or media to create a humidity barrier.
- Possible Cause 3: **LFS-1107** precipitation. High concentrations of the compound may precipitate out of the culture medium.
 - Solution: Visually inspect the media for any precipitate after adding **LFS-1107**. If precipitation is observed, consider lowering the final concentration or using a different solvent system for initial dilution, while keeping the final DMSO concentration low.

Problem 2: Lack of expected dose-dependent response in Western blot for p-ERK.

- Possible Cause 1: Suboptimal antibody concentration or incubation time.
 - Solution: Perform an antibody titration to determine the optimal concentration. Ensure consistent incubation times and temperatures as per the manufacturer's protocol.
- Possible Cause 2: Issues with protein extraction or quantification.
 - Solution: Use fresh lysis buffer containing protease and phosphatase inhibitors. Ensure accurate protein quantification using a reliable method like the BCA assay to load equal amounts of protein per lane.
- Possible Cause 3: Timing of sample collection. The inhibition of p-ERK may be transient.
 - Solution: Conduct a time-course experiment (e.g., 1, 4, 8, 24 hours) to identify the optimal time point for observing maximum p-ERK inhibition.

In Vivo Studies

Problem 3: Significant weight loss or signs of toxicity in the animal model.

- Possible Cause 1: Vehicle intolerance. The formulation vehicle may be causing adverse effects.
 - Solution: Run a vehicle-only control group to assess its tolerability. If the vehicle is the issue, explore alternative formulations.
- Possible Cause 2: Off-target effects of **LFS-1107**.
 - Solution: Conduct a dose-escalation study to determine the maximum tolerated dose (MTD). Consider reducing the dose or dosing frequency.

Problem 4: Inconsistent tumor growth inhibition.

- Possible Cause 1: Variability in tumor implantation.
 - Solution: Ensure consistent implantation technique and cell numbers. Monitor tumor growth and randomize animals into treatment groups only after tumors have reached a predetermined size.

- Possible Cause 2: Suboptimal dosing regimen.
 - Solution: Perform pharmacokinetic studies to determine the bioavailability and half-life of **LFS-1107** in the chosen animal model to optimize the dosing schedule.

Data Presentation

Table 1: In Vitro IC50 Values for **LFS-1107** in Various Cancer Cell Lines

Cell Line	Cancer Type	Key Mutation	LFS-1107 IC50 (nM)
A375	Melanoma	BRAF V600E	15.2 ± 3.1
HCT116	Colorectal Cancer	KRAS G13D	55.8 ± 8.4
A549	Lung Cancer	KRAS G12S	120.5 ± 15.7
MCF7	Breast Cancer	Wild-type	> 1000

Table 2: Summary of In Vivo Efficacy of **LFS-1107** in A375 Xenograft Model

Treatment Group	Dose (mg/kg, oral)	Dosing Frequency	Tumor Growth Inhibition (%)	Mean Body Weight Change (%)
Vehicle	-	Daily	0	+2.5
LFS-1107	10	Daily	45.3	-1.8
LFS-1107	25	Daily	78.1	-5.2
LFS-1107	50	Daily	92.5	-12.4 (Exceeded toxicity limit)

Experimental Protocols

Protocol 1: Cell Viability (MTS) Assay

- Seed 5,000 cells per well in a 96-well plate and allow them to adhere overnight.

- Prepare serial dilutions of **LFS-1107** in culture medium.
- Replace the existing medium with medium containing the various concentrations of **LFS-1107** or vehicle control (0.1% DMSO).
- Incubate the plate for 72 hours at 37°C in a 5% CO₂ incubator.
- Add 20 µL of MTS reagent to each well and incubate for 2-4 hours.
- Measure the absorbance at 490 nm using a microplate reader.
- Calculate cell viability as a percentage relative to the vehicle-treated control wells and determine the IC₅₀ value using non-linear regression analysis.

Protocol 2: Western Blot for p-ERK and Total ERK

- Plate 1×10^6 cells in a 6-well plate and allow them to attach overnight.
- Treat cells with the desired concentrations of **LFS-1107** for the determined optimal time.
- Wash cells with ice-cold PBS and lyse with RIPA buffer containing protease and phosphatase inhibitors.
- Quantify protein concentration using a BCA assay.
- Denature 20 µg of protein per sample by boiling in Laemmli buffer.
- Separate proteins by SDS-PAGE and transfer to a PVDF membrane.
- Block the membrane with 5% non-fat milk or BSA in TBST for 1 hour.
- Incubate with primary antibodies against p-ERK (1:1000), Total ERK (1:1000), and a loading control (e.g., GAPDH, 1:5000) overnight at 4°C.
- Wash the membrane and incubate with HRP-conjugated secondary antibodies for 1 hour at room temperature.

- Visualize bands using an enhanced chemiluminescence (ECL) substrate and an imaging system.

Visualizations

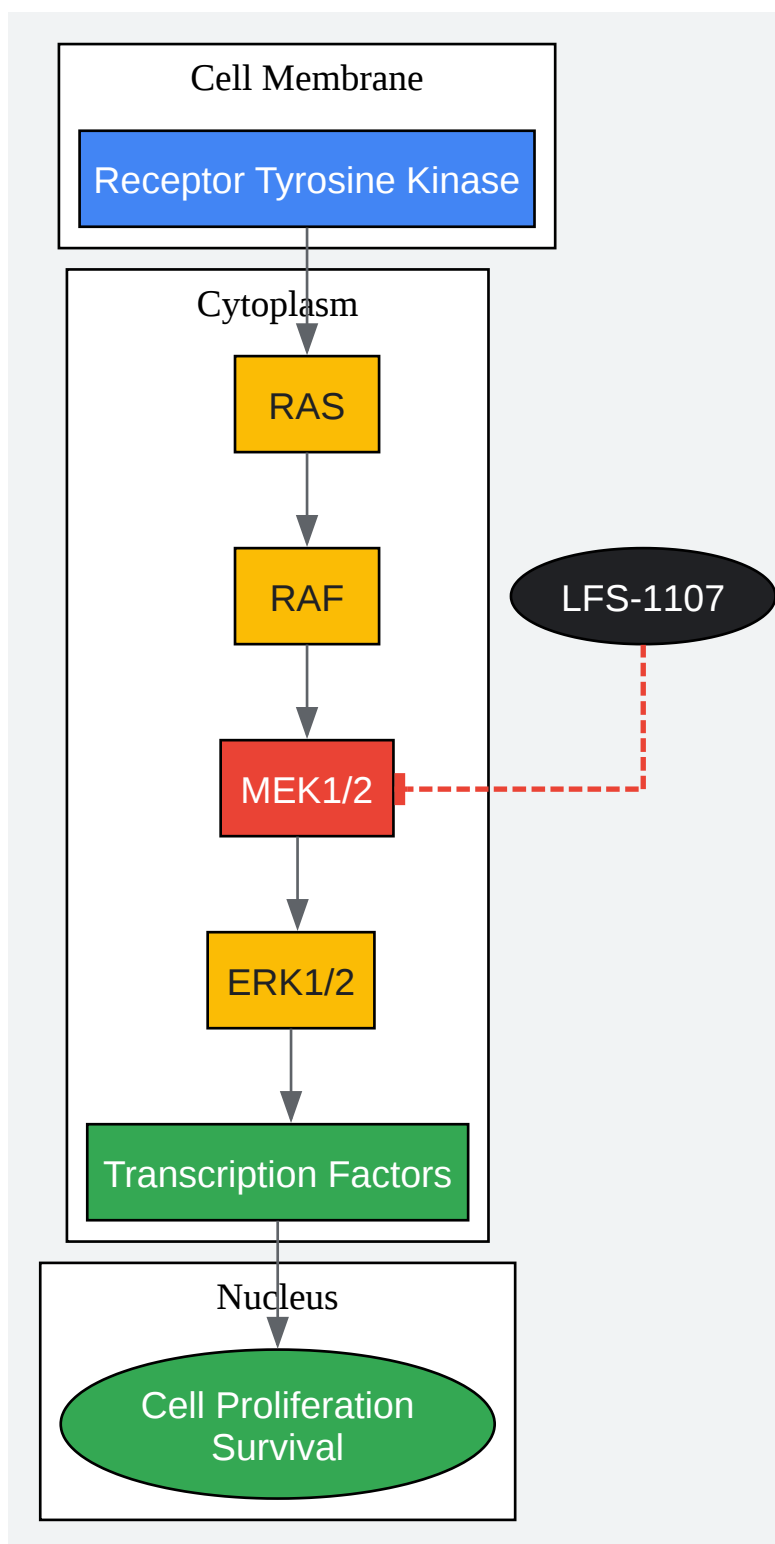

[Click to download full resolution via product page](#)

Caption: **LFS-1107** inhibits the MEK/ERK signaling pathway.

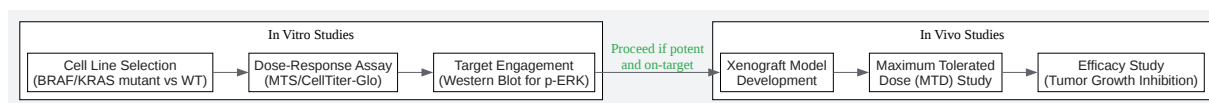

[Click to download full resolution via product page](#)

Caption: A typical preclinical experimental workflow for **LFS-1107**.

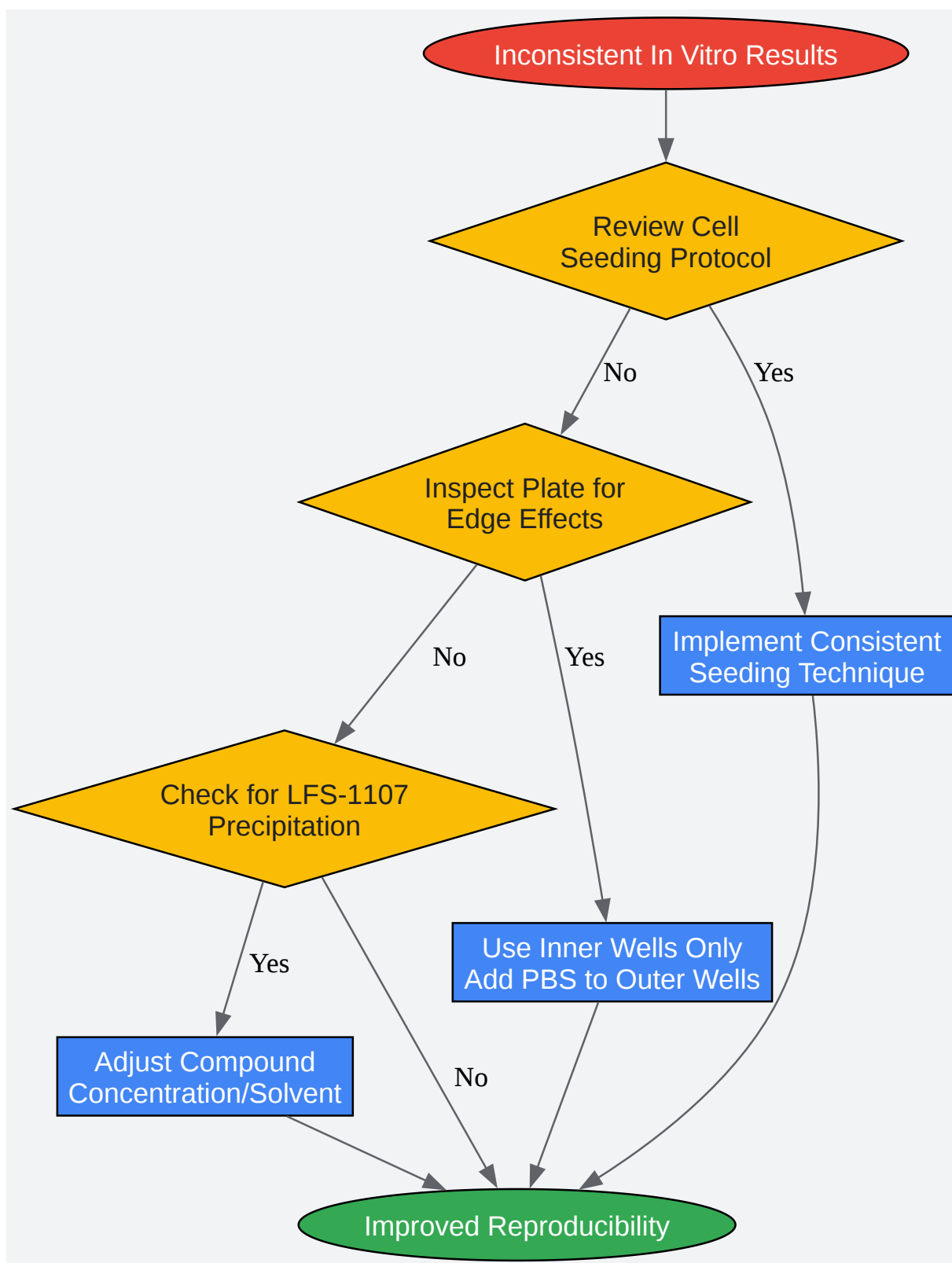

[Click to download full resolution via product page](#)

Caption: A logical flow for troubleshooting inconsistent in vitro data.

- To cite this document: BenchChem. [Navigating Preclinical Research on LFS-1107: A Technical Support Guide]. BenchChem, [2026]. [Online PDF]. Available at: [<https://www.benchchem.com/product/b15135996/docs#navigating-preclinical-research-on-lfs-1107-a-technical-support-guide>]

Disclaimer & Data Validity:

The information provided in this document is for Research Use Only (RUO) and is strictly not intended for diagnostic or therapeutic procedures. While BenchChem strives to provide accurate protocols, we make no warranties, express or implied, regarding the fitness of this product for every specific experimental setup.

Technical Support: The protocols provided are for reference purposes. Unsure if this reagent suits your experiment?

Need Industrial/Bulk Grade? [Request Custom Synthesis Quote](#)

BenchChem

Our mission is to be the trusted global source of essential and advanced chemicals, empowering scientists and researchers to drive progress in science and industry.

Contact

Address: 3281 E Guasti Rd
Ontario, CA 91761, United States
Phone: (601) 213-4426
Email: info@benchchem.com

[Contact our Ph.D. Support Team for a compatibility check](#)