

# Entrectinib-d8: A Technical Guide for Laboratory Professionals

**Author:** BenchChem Technical Support Team. **Date:** April 2026

## Compound of Interest

Compound Name: *Entrectinib-d8*

Cat. No.: *B15135475*

[Get Quote](#)

For Researchers, Scientists, and Drug Development Professionals

This technical guide provides comprehensive information on the procurement and laboratory application of **Entrectinib-d8**, a deuterated internal standard for the potent tyrosine kinase inhibitor, Entrectinib. This document outlines suppliers, purchasing details, and detailed experimental protocols for the use of **Entrectinib-d8** in a research setting.

## Supplier and Purchasing Information

**Entrectinib-d8** is available from several reputable suppliers of research chemicals. The following table summarizes purchasing information from various vendors. Researchers should note that prices are subject to change and should be confirmed on the respective supplier's website.

Supplier	Catalog Number	Purity	Available Quantities	Price (USD)
MedChemExpress	HY-12678S1	99.82%	1 mg	\$240
			5 mg	\$600
			10 mg	\$980
			50 mg	Quote
			100 mg	Quote
SmallMolecules.com	HY-12678S1	Not Specified	1 mg	Price Not Available
BenchChem	Not Specified	Not Specified	Not Specified	Check Availability & Pricing

## Mechanism of Action and Signaling Pathways

Entrectinib is a potent and selective inhibitor of the tropomyosin receptor kinases (TRK) TRKA, TRKB, and TRKC, as well as the proto-oncogene tyrosine-protein kinase ROS1 and anaplastic lymphoma kinase (ALK).[1][2] These receptor tyrosine kinases, when constitutively activated through genetic alterations such as gene fusions, can drive oncogenesis by promoting uncontrolled cell proliferation and survival.[2][3] Entrectinib functions as an ATP-competitive inhibitor, binding to the ATP-binding pocket of the kinase domain and preventing the phosphorylation of downstream substrates.[4] This blockade of signaling disrupts key cellular pathways, including the MAPK/ERK, PI3K/AKT, and JAK/STAT pathways, ultimately leading to the induction of apoptosis and cell cycle arrest in cancer cells harboring these specific genetic alterations.

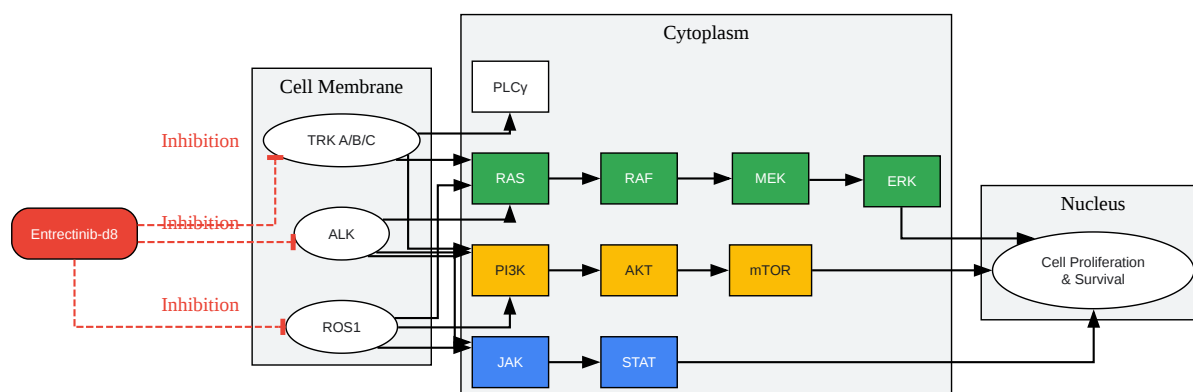

[Click to download full resolution via product page](#)

Entrectinib's inhibition of TRK, ROS1, and ALK signaling pathways.

## Experimental Protocols

The following protocols provide detailed methodologies for common laboratory experiments involving **Entrectinib-d8**.

### In Vitro Cell Viability Assay (MTT Assay)

This protocol outlines the steps to determine the half-maximal inhibitory concentration (IC<sub>50</sub>) of Entrectinib in a cancer cell line.

Materials:

- Trk-, ROS1-, or ALK-fusion positive cancer cell line (e.g., KM12, HCC78)
- Complete growth medium

- **Entrectinib-d8** (for use as an internal standard in subsequent analysis if desired, or non-deuterated Entrectinib for viability testing)
- MTT (3-(4,5-dimethylthiazol-2-yl)-2,5-diphenyltetrazolium bromide) solution (5 mg/mL in PBS)
- Solubilization solution (e.g., DMSO or 10% SDS in 0.01 M HCl)
- 96-well plates

#### Procedure:

- **Cell Seeding:** Seed cells into a 96-well plate at a density of 5,000 cells/well in 100  $\mu$ L of complete medium and allow them to adhere overnight.
- **Inhibitor Preparation:** Prepare a 2X serial dilution of Entrectinib in complete medium. A starting range of 10 nM to 10  $\mu$ M is recommended. Include a vehicle-only control (e.g., 0.1% DMSO).
- **Treatment:** Remove the media from the cells and add 100  $\mu$ L of the prepared inhibitor dilutions to the respective wells.
- **Incubation:** Incubate the plate for 72 hours at 37°C in a 5% CO<sub>2</sub> incubator.
- **MTT Addition:** Add 10  $\mu$ L of 5 mg/mL MTT reagent to each well and incubate for an additional 2-4 hours.
- **Solubilization:** Carefully remove the media and add 100  $\mu$ L of DMSO to each well to dissolve the formazan crystals.
- **Data Acquisition:** Measure the absorbance at 570 nm using a microplate reader.
- **Analysis:** Normalize the data to the vehicle-treated control wells and plot the results as percent viability versus the logarithm of the inhibitor concentration. Use a non-linear regression model to calculate the IC<sub>50</sub> value.

## Western Blot Analysis for Pathway Inhibition

This protocol describes how to assess the phosphorylation status of target kinases and their downstream signaling proteins following Entrectinib treatment.

#### Materials:

- Trk-, ROS1-, or ALK-fusion positive cancer cell line
- Entrectinib
- RIPA lysis buffer with protease and phosphatase inhibitors
- BCA protein assay kit
- SDS-PAGE gels and running buffer
- PVDF or nitrocellulose membranes
- Transfer buffer
- Blocking buffer (e.g., 5% BSA or non-fat milk in TBST)
- Primary antibodies (e.g., anti-phospho-TRK, anti-TRK, anti-phospho-AKT, anti-AKT, anti-phospho-ERK, anti-ERK)
- HRP-conjugated secondary antibodies
- Chemiluminescent substrate

#### Procedure:

- **Cell Treatment and Lysis:** Plate cells and allow them to reach 70-80% confluency. Treat cells with varying concentrations of Entrectinib for a specified time (e.g., 2 hours). Wash cells with ice-cold PBS and lyse with RIPA buffer.
- **Protein Quantification:** Determine the protein concentration of each lysate using a BCA assay.

- Electrophoresis: Load 20 µg of protein per lane onto an SDS-PAGE gel and run according to the manufacturer's instructions.
- Transfer: Transfer the proteins to a PVDF membrane.
- Blocking & Incubation: Block the membrane with blocking buffer for 1 hour at room temperature. Incubate with the primary antibody overnight at 4°C.
- Secondary Antibody Incubation: Wash the membrane with TBST and incubate with the appropriate HRP-conjugated secondary antibody for 1 hour at room temperature.
- Detection: Wash the membrane, add the chemiluminescent substrate, and capture the signal using an imaging system.
- Analysis: Quantify the band intensities and normalize to a loading control (e.g., β-actin or GAPDH) and the total protein levels to determine the change in phosphorylation.

## LC-MS/MS Quantification of Entrectinib

This protocol provides a general method for the quantification of Entrectinib in plasma samples using **Entrectinib-d8** as an internal standard.

Materials:

- Human or rat plasma samples
- **Entrectinib-d8** (internal standard)
- Acetonitrile
- Formic acid
- UPLC-MS/MS system

Sample Preparation (Protein Precipitation):

- To 100 µL of plasma sample, add 50 µL of **Entrectinib-d8** internal standard solution (e.g., 500 ng/mL in methanol).

- Add 250  $\mu\text{L}$  of acetonitrile, vortex for 5 minutes, and centrifuge at 4000 rpm for 10 minutes.
- Transfer the supernatant to an autosampler vial for analysis.

LC-MS/MS Parameters (example):

- Column: Acquity UPLC BEH C18 (2.1  $\times$  50 mm, 1.7  $\mu\text{m}$ )
- Mobile Phase A: 0.1% formic acid in water
- Mobile Phase B: Acetonitrile
- Gradient Elution: A suitable gradient to separate the analyte from matrix components.
- Ionization Mode: Positive ion electrospray ionization (ESI+)
- MRM Transitions:
  - Entrectinib:  $m/z$  561.3  $\rightarrow$  475.1
  - **Entrectinib-d8**:  $m/z$  569.3  $\rightarrow$  483.1 (Note: exact transition may vary based on deuteration pattern)

## In Vivo Mouse Xenograft Study

This protocol outlines a general procedure for evaluating the in vivo efficacy of Entrectinib in a mouse xenograft model.

Materials:

- Immunocompromised mice (e.g., SCID or athymic nu/nu)
- Cancer cell line for xenograft implantation
- Entrectinib
- Vehicle (e.g., 0.5% methylcellulose with 1% Tween 80)
- Calipers for tumor measurement

#### Procedure:

- **Xenograft Implantation:** Subcutaneously inject cancer cells into the flank of the mice.
- **Tumor Growth and Randomization:** Allow tumors to reach a palpable size (e.g., 100-150 mm<sup>3</sup>). Randomize mice into treatment and control groups.
- **Dosing:** Administer Entrectinib orally by gavage at the desired dose (e.g., 10-60 mg/kg) and schedule (e.g., once or twice daily). The control group receives the vehicle.
- **Monitoring:** Measure tumor dimensions with calipers twice a week and calculate tumor volume using the formula:  $(\text{length} \times \text{width}^2)/2$ . Monitor animal body weight as an indicator of toxicity.
- **Endpoint:** Continue treatment for a predetermined period (e.g., 21 days) or until tumors in the control group reach a specified size.
- **Analysis:** Compare tumor growth inhibition between the treated and control groups. At the end of the study, tumors can be harvested for pharmacodynamic analysis (e.g., Western blot).

## Experimental and Logical Workflows

The following diagrams illustrate typical workflows for the evaluation of tyrosine kinase inhibitors like Entrectinib.

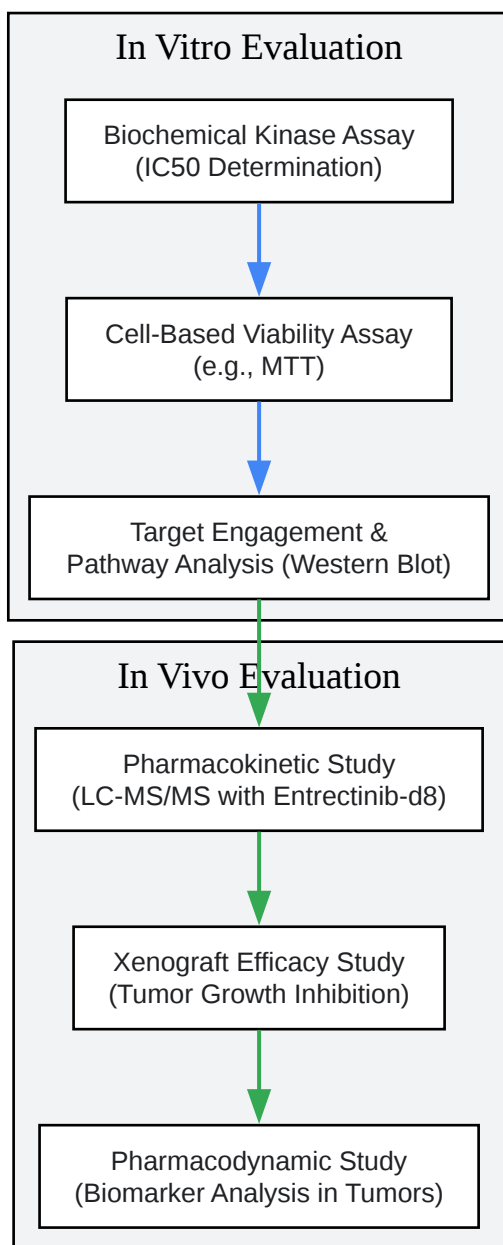

[Click to download full resolution via product page](#)

Experimental workflow for tyrosine kinase inhibitor evaluation.



[Click to download full resolution via product page](#)

Logical flow of drug efficacy evaluation.

#### Need Custom Synthesis?

BenchChem offers custom synthesis for rare earth carbides and specific isotopic labeling.

Email: [info@benchchem.com](mailto:info@benchchem.com) or [Request Quote Online](#).

## References

- [1. medchemexpress.com \[medchemexpress.com\]](https://www.medchemexpress.com)
- [2. ALK Fusion Partners Impact Response to ALK Inhibition: Differential Effects on Sensitivity, Cellular Phenotypes, and Biochemical Properties - PMC \[pmc.ncbi.nlm.nih.gov\]](#)
- [3. Entrectinib is a potent inhibitor of Trk-driven neuroblastomas in a xenograft mouse model - PubMed \[pubmed.ncbi.nlm.nih.gov\]](#)
- [4. benchchem.com \[benchchem.com\]](https://www.benchchem.com)
- To cite this document: BenchChem. [Entrectinib-d8: A Technical Guide for Laboratory Professionals]. BenchChem, [2026]. [Online PDF]. Available at: [\[https://www.benchchem.com/product/b15135475/docs#entrectinib-d8-a-technical-guide-for-laboratory-professionals\]](https://www.benchchem.com/product/b15135475/docs#entrectinib-d8-a-technical-guide-for-laboratory-professionals)

---

### Disclaimer & Data Validity:

The information provided in this document is for Research Use Only (RUO) and is strictly not intended for diagnostic or therapeutic procedures. While BenchChem strives to provide accurate protocols, we make no warranties, express or implied, regarding the fitness of this product for every specific experimental setup.

**Technical Support:** The protocols provided are for reference purposes. Unsure if this reagent suits your experiment?

**Need Industrial/Bulk Grade?** [Request Custom Synthesis Quote](#)

# BenchChem

Our mission is to be the trusted global source of essential and advanced chemicals, empowering scientists and researchers to drive progress in science and industry.

## Contact

Address: 3281 E Guasti Rd

Ontario, CA 91761, United States

Phone: (601) 213-4426

Email: [info@benchchem.com](mailto:info@benchchem.com)

[Contact our Ph.D. Support Team for a compatibility check](#)