

Application Notes and Protocols for Multi-Kinase-IN-6 in Angiogenesis Research

Author: BenchChem Technical Support Team. **Date:** April 2026

Compound of Interest

Compound Name: Multi-kinase-IN-6

Cat. No.: B15135921

[Get Quote](#)

For Researchers, Scientists, and Drug Development Professionals

Introduction

Multi-kinase-IN-6 is a potent, orally bioavailable, ATP-competitive small molecule inhibitor that targets multiple receptor tyrosine kinases (RTKs) crucial for angiogenesis, the formation of new blood vessels from pre-existing ones. Its primary targets include Vascular Endothelial Growth Factor Receptors (VEGFRs), Platelet-Derived Growth Factor Receptors (PDGFRs), and Fibroblast Growth Factor Receptors (FGFRs). By simultaneously blocking these key signaling pathways, **Multi-kinase-IN-6** serves as a powerful tool for investigating the molecular mechanisms of angiogenesis and for the preclinical evaluation of anti-angiogenic therapeutic strategies. These application notes provide detailed protocols for utilizing **Multi-kinase-IN-6** in a variety of in vitro, ex vivo, and in vivo angiogenesis models.

Mechanism of Action

Angiogenesis is a complex process regulated by a balance of pro- and anti-angiogenic factors. [1] Growth factors like VEGF, PDGF, and FGF play a pivotal role in stimulating endothelial cell proliferation, migration, and differentiation to form new blood vessels.[2][3] These ligands bind to their respective receptor tyrosine kinases on the surface of endothelial cells, leading to

receptor dimerization and autophosphorylation. This activation triggers downstream intracellular signaling cascades, principally the PI3K/Akt and MAPK/ERK pathways, which are central to the angiogenic process.[4][5]

Multi-kinase-IN-6 exerts its anti-angiogenic effects by binding to the ATP-binding pocket of VEGFRs, PDGFRs, and FGFRs, thereby preventing their phosphorylation and subsequent activation. This blockade inhibits the downstream signaling pathways, ultimately leading to a reduction in endothelial cell proliferation, migration, and tube formation.

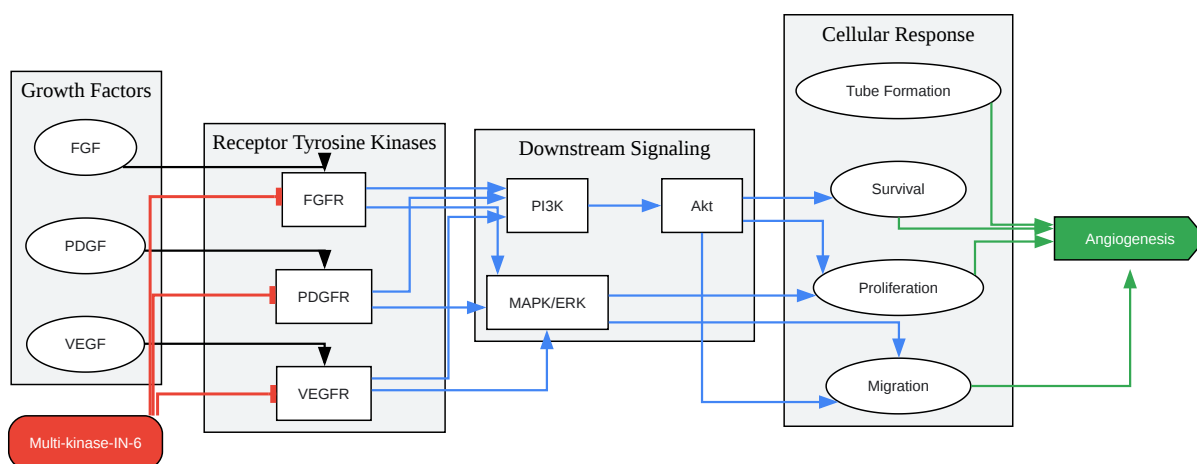

[Click to download full resolution via product page](#)

Figure 1: Mechanism of action of **Multi-kinase-IN-6**.

Quantitative Data

The inhibitory activity of **Multi-kinase-IN-6** against its primary targets and its effects on key angiogenic processes are summarized below.

Table 1: In Vitro Kinase Inhibitory Activity of **Multi-kinase-IN-6**

Kinase Target	IC50 (nM)
VEGFR1	5.2
VEGFR2 (KDR)	1.5
VEGFR3	8.1
PDGFR α	12.5
PDGFR β	3.7
FGFR1	25.8
FGFR2	18.3
c-Kit	45.1

Table 2: Cellular Anti-Angiogenic Activity of **Multi-kinase-IN-6**

Assay	Cell Type	IC50 (nM)
HUVEC Proliferation (VEGF-stimulated)	HUVEC	15.6
HUVEC Migration (VEGF-stimulated)	HUVEC	22.4
HUVEC Tube Formation on Matrigel	HUVEC	18.9

Experimental Protocols

Detailed methodologies for key experiments to evaluate the anti-angiogenic effects of **Multi-kinase-IN-6** are provided below.

In Vitro Endothelial Cell Tube Formation Assay

This assay assesses the ability of endothelial cells to form capillary-like structures (tubes) on a basement membrane matrix, a key step in angiogenesis.

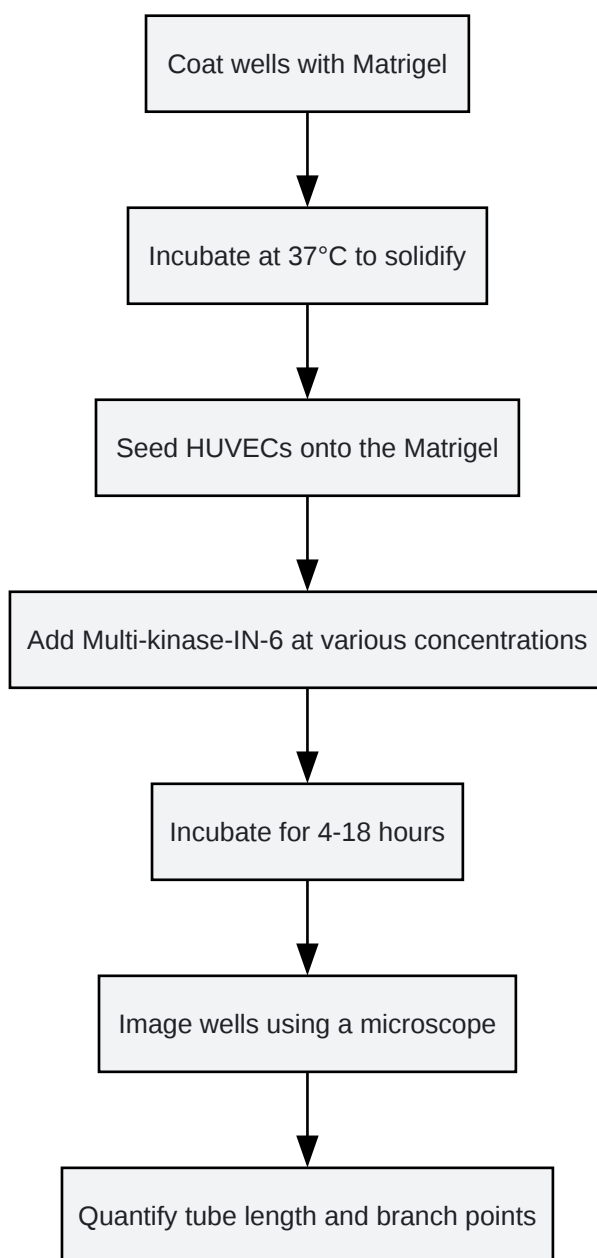

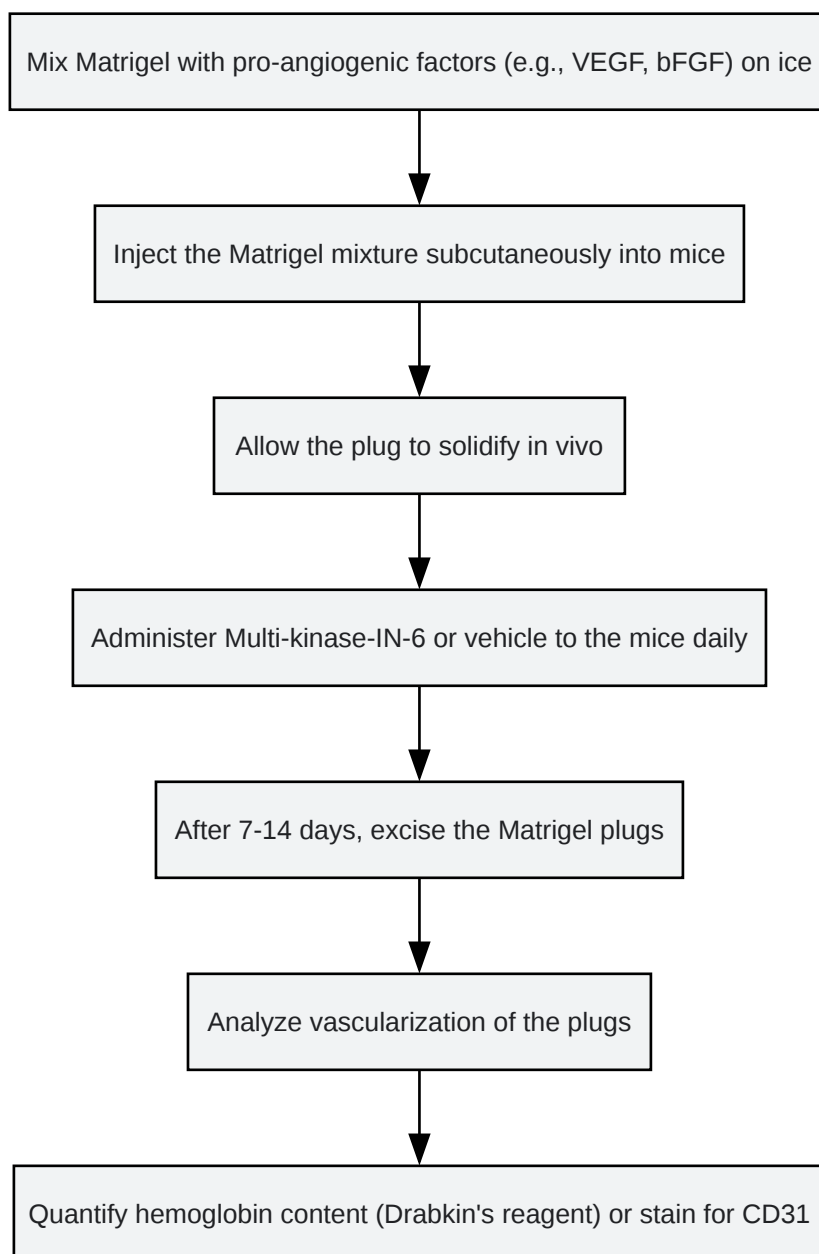

[Click to download full resolution via product page](#)

Need Custom Synthesis?

BenchChem offers custom synthesis for rare earth carbides and specific isotopic labeling.

Email: info@benchchem.com or [Request Quote Online](#).

References

- [1. Consensus guidelines for the use and interpretation of angiogenesis assays - PMC \[pmc.ncbi.nlm.nih.gov\]](#)
- [2. Anti-angiogenic tyrosine kinase inhibitors: what is their mechanism of action? - PMC \[pmc.ncbi.nlm.nih.gov\]](#)
- [3. aacrjournals.org \[aacrjournals.org\]](#)
- [4. Angiogenesis Antibody Sampler Kit | Cell Signaling Technology \[cellsignal.com\]](#)
- [5. pubs.acs.org \[pubs.acs.org\]](#)
- To cite this document: BenchChem. [Application Notes and Protocols for Multi-Kinase-IN-6 in Angiogenesis Research]. BenchChem, [2026]. [Online PDF]. Available at: [\[https://www.benchchem.com/product/b15135921/docs#application-notes-and-protocols-for-multi-kinase-in-6-in-angiogenesis-research\]](https://www.benchchem.com/product/b15135921/docs#application-notes-and-protocols-for-multi-kinase-in-6-in-angiogenesis-research)

Disclaimer & Data Validity:

The information provided in this document is for Research Use Only (RUO) and is strictly not intended for diagnostic or therapeutic procedures. While BenchChem strives to provide accurate protocols, we make no warranties, express or implied, regarding the fitness of this product for every specific experimental setup.

Technical Support: The protocols provided are for reference purposes. Unsure if this reagent suits your experiment?

Need Industrial/Bulk Grade? [Request Custom Synthesis Quote](#)

BenchChem

Our mission is to be the trusted global source of essential and advanced chemicals, empowering scientists and researchers to drive progress in science and industry.

Contact

Address: 3281 E Guasti Rd
Ontario, CA 91761, United States
Phone: (601) 213-4426
Email: info@benchchem.com

Contact our Ph.D. Support Team for a compatibility check