

# Technical Comparison Guide: FTIR Characterization of 1,3-Benzothiazole-5- sulfonamide

**Author:** BenchChem Technical Support Team. **Date:** April 2026

## Compound of Interest

Compound Name:	1,3-Benzothiazole-5-sulfonamide
CAS No.:	21262-99-7
Cat. No.:	B15124600

[Get Quote](#)

## Executive Summary & Application Scope

**1,3-Benzothiazole-5-sulfonamide** serves as a pivotal pharmacophore in medicinal chemistry. Its structural integrity relies on the coexistence of the electron-deficient benzothiazole ring and the polar sulfonamide moiety.

For researchers, the "performance" of FTIR analysis lies in its ability to simultaneously validate these two distinct domains without the solvent interference common in NMR. This guide outlines the specific wavenumbers required to confirm identity and purity, differentiating the 5-isomer from common impurities like the 6-isomer or hydrolysis products.

## Quick Reference: Key Diagnostic Bands

Functional Group	Vibration Mode	Wavenumber (cm <sup>-1</sup> )	Intensity	Diagnostic Value
Sulfonamide (-SO <sub>2</sub> NH <sub>2</sub> )	N-H Stretching (Asym/Sym)	3380 / 3260	Medium-Strong	Confirms primary sulfonamide (doublet).[1]
Sulfonyl (O=S=O)	Asymmetric Stretch	1320–1360	Strong	Primary indicator of sulfonylation.
Sulfonyl (O=S=O)	Symmetric Stretch	1140–1160	Strong	Confirms S-oxidation state.
Thiazole Ring	C=N Stretching	1600–1640	Medium	Distinguishes from benzenesulfonamide.
C-S Bond	C-S Stretching	600–700	Weak-Medium	Fingerprint for thiazole core.[2]

## Detailed Spectral Analysis

### The Sulfonamide Region (High Frequency & Mid-IR)

The sulfonamide group acts as the primary "reporter" in the spectrum.

- N-H Stretching (3400–3200 cm<sup>-1</sup>):
  - Expect a doublet pattern characteristic of a primary amide (-NH<sub>2</sub>).
  - Asymmetric Stretch (~3380 cm<sup>-1</sup>): Higher energy, anti-phase vibration.
  - Symmetric Stretch (~3260 cm<sup>-1</sup>): Lower energy, in-phase vibration.
  - Note: Broadening in this region often indicates moisture contamination or extensive hydrogen bonding in the solid state.
- Sulfonyl Stretching (1400–1100 cm<sup>-1</sup>):

- The O=S=O asymmetric stretch appears as a prominent band between 1320–1360  $\text{cm}^{-1}$ .
- The symmetric stretch is sharper and found at 1140–1160  $\text{cm}^{-1}$ .
- Protocol Check: If these bands are split or shifted significantly ( $>20 \text{ cm}^{-1}$ ), check for metal coordination (if synthesizing metallodrugs) or polymorphism.

## The Benzothiazole Core (Fingerprint Region)

The heterocyclic ring provides the structural backbone.

- C=N Stretching (1600–1640  $\text{cm}^{-1}$ ):
  - This band confirms the integrity of the thiazole ring. It is often less intense than a carbonyl C=O but sharp.
  - Differentiation: In simple benzenesulfonamides, this peak is absent.
- Aromatic C=C (1600–1450  $\text{cm}^{-1}$ ):
  - Typical skeletal vibrations of the fused benzene ring. Look for a doublet or triplet pattern near 1470  $\text{cm}^{-1}$ .
- C-S Stretching (600–700  $\text{cm}^{-1}$ ):
  - A critical but often overlooked band. While weak in FTIR, its presence in the lower frequency region confirms the thioether linkage within the ring.

## Comparative Analysis: Performance vs. Alternatives

To validate the utility of FTIR for this specific compound, we compare it against structural analogs (to demonstrate specificity) and alternative techniques (to demonstrate utility).

### Comparison 1: Structural Specificity

Can FTIR distinguish the 5-sulfonamide from its precursors?

Feature	1,3-Benzothiazole (Parent)	Benzenesulfonamide (Analog)	1,3-Benzothiazole-5-sulfonamide (Target)
3200–3400 $\text{cm}^{-1}$	Absent (No NH)	Doublet ( $\text{NH}_2$ )	Doublet ( $\text{NH}_2$ )
1600–1640 $\text{cm}^{-1}$	Present (C=N)	Absent	Present (C=N)
1320 / 1150 $\text{cm}^{-1}$	Absent	Strong ( $\text{SO}_2$ )	Strong ( $\text{SO}_2$ )
Conclusion	Lacks polar handle.	Lacks heterocyclic C=N.	Unique combination of C=N + $\text{SO}_2$ + $\text{NH}_2$ .

## Comparison 2: Technique Suitability (FTIR vs. Raman)

When should you use FTIR over Raman for this compound?

- **FTIR Strength:** The Sulfonyl (S=O) and Amine (N-H) bonds are highly polar, resulting in strong dipole changes. This makes FTIR the superior technique for confirming the functionalization (i.e., did the sulfonamide group attach?).
- **Raman Strength:** The C-S-C and S-S (if disulfide impurities exist) vibrations are more polarizable and appear very strongly in Raman.
- **Recommendation:** Use FTIR for routine QC and purity confirmation. Use Raman if you suspect ring degradation or disulfide byproduct formation.

## Experimental Protocol (Self-Validating)

### Method: KBr Pellet Transmission

Why: ATR (Attenuated Total Reflectance) is convenient but can suppress weak peaks in the high-wavenumber region due to depth of penetration issues. For publication-quality resolution of the N-H doublet, KBr transmission is preferred.

Step-by-Step Workflow:

- **Preparation:** Mix 1–2 mg of dry **1,3-Benzothiazole-5-sulfonamide** with ~200 mg of spectroscopic grade KBr.

- Grinding: Grind in an agate mortar until a fine, uniform powder is achieved (prevents Christiansen effect/scattering).
- Compression: Press at 8–10 tons for 2 minutes to form a transparent disc.
- Acquisition: Scan from 4000 to 400  $\text{cm}^{-1}$  (Resolution: 2  $\text{cm}^{-1}$ , Scans: 32).
- Validation Check:
  - Baseline: Should be flat and >80% transmittance at 4000  $\text{cm}^{-1}$ .
  - Water: If a broad hump appears >3400  $\text{cm}^{-1}$ , dry the sample and re-press.

## Structural & Spectral Logic Diagram

The following diagram illustrates the logical flow for assigning spectral bands to specific structural fragments of the molecule.

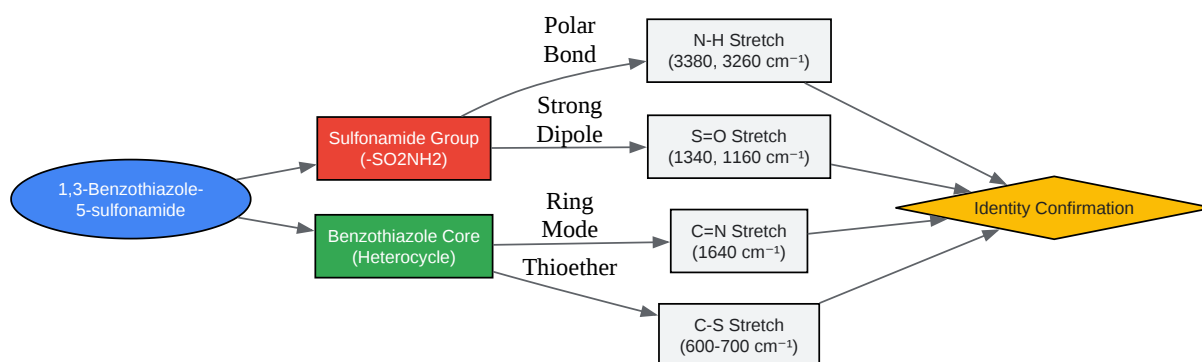

[Click to download full resolution via product page](#)

Caption: Logical mapping of structural fragments to diagnostic FTIR vibrational modes.

## References

- National Center for Biotechnology Information (2025). PubChem Compound Summary for CID 131312087, 2-Aminobenzo[d]thiazole-5-sulfonamide. Retrieved from [[Link](#)]
- Silverstein, R. M., Webster, F. X., & Kiemle, D. J. (2005). Spectrometric Identification of Organic Compounds. John Wiley & Sons. (Standard reference for general group frequencies: Sulfonamides and Thiazoles).
- InstaNANO.FTIR Functional Group Database. Retrieved from [[Link](#)]
- MDPI (2022). Computational Study of Benzothiazole Derivatives for Conformational and Spectroscopic Features. Retrieved from [[Link](#)]

### Need Custom Synthesis?

BenchChem offers custom synthesis for rare earth carbides and specific isotopic labeling.

Email: [info@benchchem.com](mailto:info@benchchem.com) or [Request Quote Online](#).

## Sources

- [1. ripublication.com](https://www.ripublication.com) [[ripublication.com](https://www.ripublication.com)]
- [2. pdf.benchchem.com](https://www.pdf.benchchem.com) [[pdf.benchchem.com](https://www.pdf.benchchem.com)]
- To cite this document: BenchChem. [Technical Comparison Guide: FTIR Characterization of 1,3-Benzothiazole-5-sulfonamide]. BenchChem, [2026]. [Online PDF]. Available at: [<https://www.benchchem.com/product/b15124600/docs#technical-comparison-guide-ftir-characterization-of-1-3-benzothiazole-5-sulfonamide>]

---

### Disclaimer & Data Validity:

The information provided in this document is for Research Use Only (RUO) and is strictly not intended for diagnostic or therapeutic procedures. While BenchChem strives to provide accurate protocols, we make no warranties, express or implied, regarding the fitness of this product for every specific experimental setup.

**Technical Support:** The protocols provided are for reference purposes. Unsure if this reagent suits your experiment?

**Need Industrial/Bulk Grade?** [Request Custom Synthesis Quote](#)

## BenchChem

Our mission is to be the trusted global source of essential and advanced chemicals, empowering scientists and researchers to drive progress in science and industry.

### Contact

Address: 3281 E Guasti Rd  
Ontario, CA 91761, United States  
Phone: (601) 213-4426  
Email: [info@benchchem.com](mailto:info@benchchem.com)

[Contact our Ph.D. Support Team for a compatibility check](#)