

A Technical Guide to the Reactivity Profile of 2-Chloro-5-isopropoxy pyridine

Author: BenchChem Technical Support Team. **Date:** January 2026

Compound of Interest

Compound Name: 2-Chloro-5-isopropoxy pyridine

Cat. No.: B1512368

[Get Quote](#)

Abstract

2-Chloro-5-isopropoxy pyridine is a key heterocyclic building block in modern synthetic chemistry, particularly valued in the fields of medicinal and agricultural science. Its utility stems from a nuanced reactivity profile governed by the electronic interplay of the pyridine nitrogen, a C2-chloro substituent, and a C5-isopropoxy group. This guide provides an in-depth analysis of the molecule's electronic architecture and explores its reactivity across three major classes of transformations: electrophilic aromatic substitution, nucleophilic aromatic substitution, and palladium-catalyzed cross-coupling reactions. By elucidating the causality behind its regiochemical outcomes and providing field-proven experimental protocols, this document serves as a comprehensive resource for chemists seeking to strategically employ this versatile intermediate in complex molecule synthesis.

The Electronic Architecture: A Tale of Competing Influences

The reactivity of any aromatic system is dictated by the distribution of electron density within the ring. In **2-chloro-5-isopropoxy pyridine**, three distinct structural features engage in an electronic "tug-of-war" that defines its chemical behavior.

- **The Pyridine Nitrogen:** As a heteroatom, nitrogen is more electronegative than carbon. It exerts a strong electron-withdrawing effect through both induction (σ -network) and resonance (π -network), generally deactivating the ring towards electrophilic attack.^{[1][2]}

Conversely, this electron deficiency, particularly at the positions ortho (C2, C6) and para (C4) to the nitrogen, makes the ring susceptible to nucleophilic attack.[3][4][5]

- The C2-Chloro Substituent: The chlorine atom is highly electronegative and withdraws electron density via induction, further deactivating the ring. However, its most critical role is that of an excellent leaving group, priming the C2 position for nucleophilic aromatic substitution (S_NAr) and serving as the reactive handle for a vast array of cross-coupling reactions.
- The C5-Isopropoxy Group: The oxygen atom of the isopropoxy group possesses lone pairs of electrons that it can donate into the pyridine π-system via resonance (+R effect). This effect is electron-donating and activating, opposing the deactivating effects of the nitrogen and chlorine. This resonance donation preferentially increases electron density at the positions ortho (C4, C6) and para (C2) to itself.

The net result is a highly polarized ring. The C2 position is electron-poor and equipped with a leaving group, making it the primary site for nucleophilic and cross-coupling reactions. The C4 and C6 positions are electronically enriched by the isopropoxy group, marking them as the most likely (though still challenging) sites for electrophilic attack.

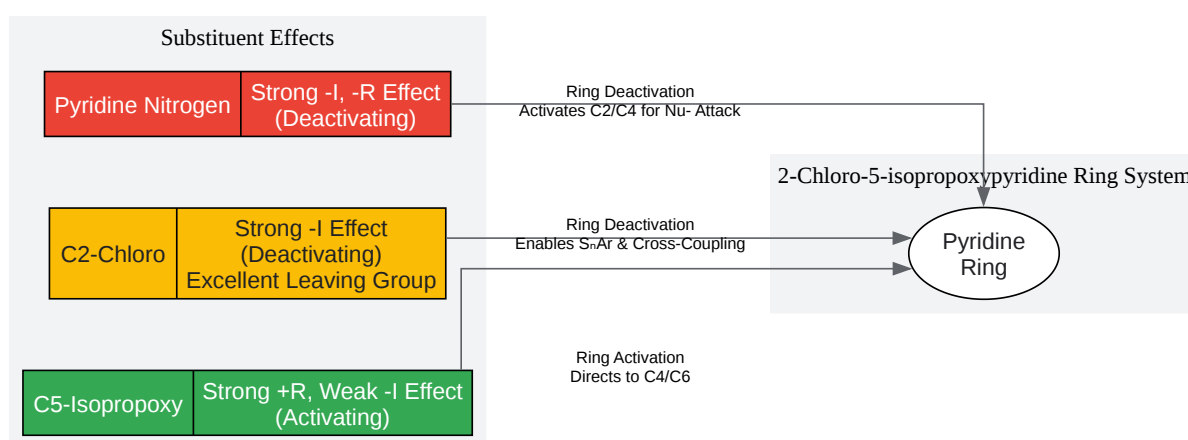

[Click to download full resolution via product page](#)

Figure 1: Competing electronic effects on the pyridine core.

Electrophilic Aromatic Substitution (EAS): A Challenging Transformation

Pyridine itself undergoes electrophilic aromatic substitution only under harsh conditions, with substitution occurring primarily at the C3 position.[1][2] The powerful deactivating nature of the pyridinium cation, formed under the acidic conditions typical for EAS (e.g., nitration), makes the reaction exceedingly difficult.[1]

For **2-chloro-5-isopropoxypyridine**, the activating, ortho,para-directing isopropoxy group at C5 competes with the deactivating, meta-directing influences of the ring nitrogen and the C2-chloro group.

- Nitrogen directs to: C3, C5
- Chloro group directs to: C3, C5
- Isopropoxy group directs to: C4, C6

The C4 and C6 positions benefit from the strong resonance donation of the isopropoxy group. However, the overall electron-deficient nature of the ring means that forcing conditions are likely required, and yields may be modest. The C4 position is generally favored over C6, as it is para to the activating group and avoids the steric hindrance and proximal inductive withdrawal from the C2-chloro group.

Representative Protocol: Nitration

Causality: Nitration requires a potent electrophile, the nitronium ion (NO_2^+), generated from nitric acid and a strong dehydrating acid like sulfuric acid.[6] Due to the deactivated nature of the pyridine ring, elevated temperatures are necessary to achieve a reasonable reaction rate.

Methodology:

- **Reaction Setup:** To a cooled (0 °C) flask containing concentrated sulfuric acid (5 mL), add **2-chloro-5-isopropoxy pyridine** (1.0 mmol) portion-wise, ensuring the temperature remains below 10 °C.
- **Reagent Addition:** Add fuming nitric acid (1.1 mmol) dropwise to the stirred solution, maintaining the temperature at 0 °C.
- **Reaction:** After addition is complete, allow the mixture to warm to room temperature, then heat to 60-70 °C.
- **Monitoring:** The reaction must be monitored by a validated method (e.g., TLC or LC-MS) to determine the point of optimal conversion and minimize byproduct formation.
- **Work-up:** Carefully pour the cooled reaction mixture onto crushed ice and neutralize with a saturated aqueous solution of sodium bicarbonate.
- **Extraction & Purification:** Extract the aqueous layer with a suitable organic solvent (e.g., ethyl acetate, 3x). Combine the organic layers, dry over anhydrous sodium sulfate, filter, and concentrate under reduced pressure. Purify the crude product by flash column chromatography.

Nucleophilic Aromatic Substitution (S_NAr): The Predominant Pathway

The convergence of an electron-deficient ring system and a good leaving group at the C2 position makes S_NAr the most facile and high-yielding reaction for this substrate.^[7] The reaction proceeds via a two-step addition-elimination mechanism involving a resonance-stabilized anionic intermediate known as a Meisenheimer complex.^[8] The stability of this intermediate is the key to the reaction's success; a resonance structure that places the negative charge directly on the electronegative ring nitrogen provides a significant stabilizing contribution, a feature available only with attack at the C2 or C4 positions.^{[3][5]}

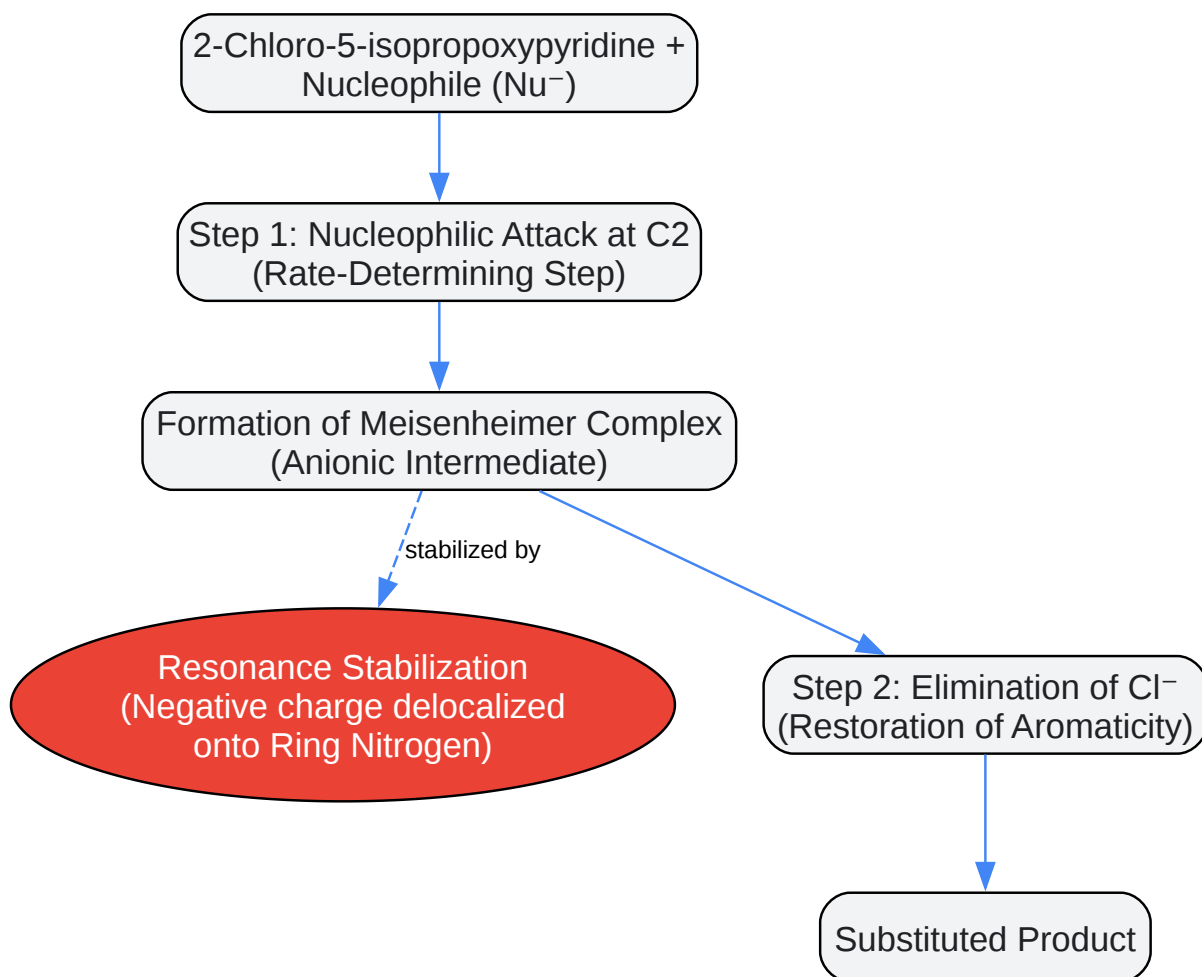

[Click to download full resolution via product page](#)

Figure 2: Workflow for the Nucleophilic Aromatic Substitution (SNAr) mechanism.

Representative Protocol: Amination with Morpholine

Causality: This protocol exemplifies a classic SNAr displacement. A polar aprotic solvent like DMSO is used to solvate the cation of the base and leave the anionic nucleophile highly reactive. A base (e.g., K_2CO_3) is required to deprotonate the amine, generating the active nucleophile in situ, or to act as an acid scavenger if the amine salt is formed.

Methodology:

- **Reaction Setup:** To a dry reaction vessel under an inert atmosphere (e.g., Nitrogen), add **2-chloro-5-isopropoxy pyridine** (1.0 mmol), morpholine (1.2 mmol), and potassium carbonate (2.0 mmol).
- **Solvent Addition:** Add anhydrous dimethyl sulfoxide (DMSO, 5 mL).
- **Reaction:** Heat the mixture to 100-120 °C with vigorous stirring.
- **Monitoring:** Track the consumption of the starting material by TLC or LC-MS. Reactions are typically complete within 4-12 hours.
- **Work-up:** Cool the reaction to room temperature and dilute with water (20 mL).
- **Extraction & Purification:** Extract the product with ethyl acetate (3 x 20 mL). Wash the combined organic layers with brine, dry over anhydrous magnesium sulfate, filter, and concentrate in vacuo. Purify the residue via silica gel chromatography.

Palladium-Catalyzed Cross-Coupling: A Gateway to Molecular Complexity

The C(sp²)-Cl bond at the C2 position is an ideal handle for transition metal-catalyzed cross-coupling reactions, enabling the formation of C-C, C-N, and C-O bonds with exceptional functional group tolerance.^{[9][10][11]}

Suzuki-Miyaura Coupling

This reaction is one of the most powerful methods for constructing biaryl structures.^[12] It involves the coupling of the chloropyridine with an organoboron reagent (e.g., a boronic acid or ester) catalyzed by a palladium complex.^{[13][14]} The choice of ligand is critical for activating the C-Cl bond.^[15]

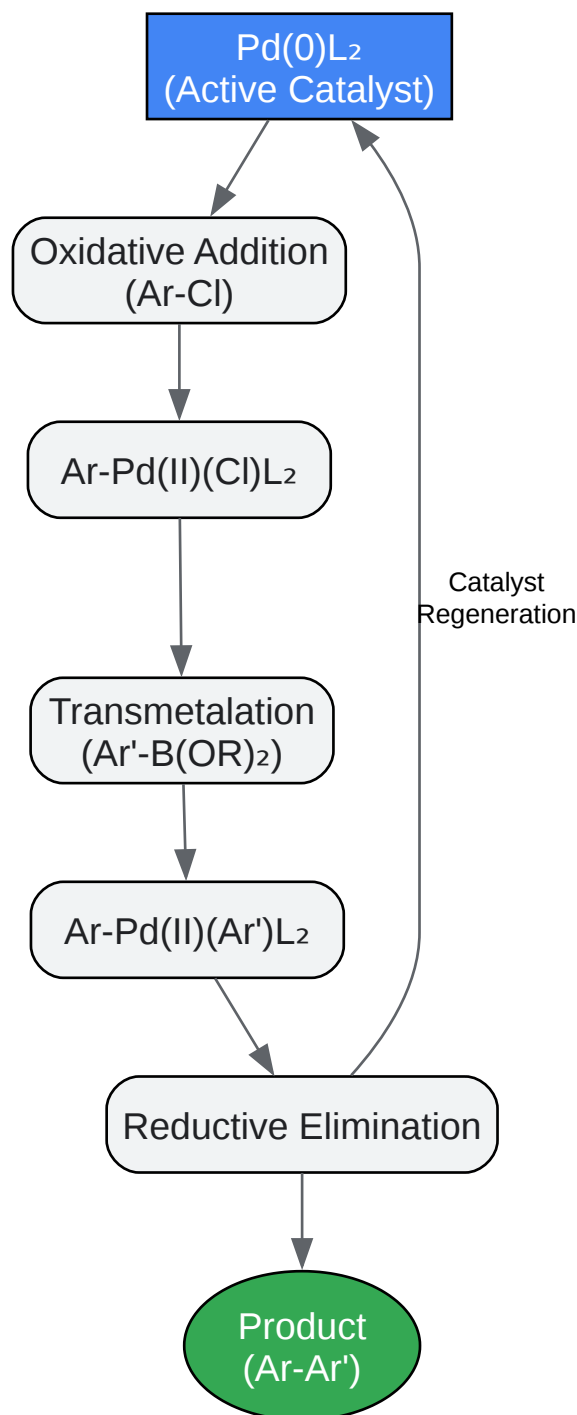

[Click to download full resolution via product page](#)

Figure 3: The catalytic cycle for the Suzuki-Miyaura cross-coupling reaction.

Representative Protocol: Suzuki Coupling with Phenylboronic Acid

Causality: This protocol uses a Pd(0) catalyst generated in situ or a pre-catalyst. A bulky, electron-rich phosphine ligand (e.g., SPhos, XPhos) is essential to facilitate the oxidative addition of the relatively inert C-Cl bond.^[16] An aqueous base (e.g., K₂CO₃, K₃PO₄) is required for the transmetalation step. A dioxane/water solvent system is commonly used to dissolve both the organic and inorganic reagents.

Methodology:

- **Reaction Setup:** In a Schlenk flask under an inert atmosphere, combine **2-chloro-5-isopropoxyppyridine** (1.0 mmol), phenylboronic acid (1.2 mmol), and potassium phosphate (2.0 mmol).
- **Catalyst Premix:** In a separate vial, dissolve a palladium source (e.g., Pd(OAc)₂, 2 mol%) and a suitable ligand (e.g., SPhos, 4 mol%) in a small amount of the reaction solvent.
- **Solvent & Catalyst Addition:** Add anhydrous 1,4-dioxane (8 mL) and degassed water (2 mL) to the Schlenk flask. Add the catalyst premix via syringe.
- **Reaction:** Heat the mixture to 100 °C with vigorous stirring.
- **Monitoring:** Monitor reaction progress by GC-MS or LC-MS. The reaction is typically complete within 12-24 hours.^[16]
- **Work-up & Purification:** Cool the reaction, dilute with ethyl acetate, and wash with water and brine. Dry the organic layer over anhydrous sodium sulfate, filter, and concentrate. Purify by flash column chromatography.

Buchwald-Hartwig Amination

As a powerful alternative to S_NAr, the Buchwald-Hartwig amination allows for C-N bond formation under potentially milder conditions and with a broader scope of amines.^{[17][18]} The reaction is particularly valuable for coupling less nucleophilic amines.

Representative Protocol: Buchwald-Hartwig Amination with Aniline

Causality: The oxidative addition of the C-Cl bond is often the rate-limiting step, necessitating a highly active catalyst system.^[19] Sterically hindered biarylphosphine ligands are crucial for promoting both the oxidative addition and the final reductive elimination step. A strong, non-nucleophilic base like sodium tert-butoxide is typically required.

Methodology:

- **Reaction Setup:** To an oven-dried Schlenk tube under an inert atmosphere, add the palladium pre-catalyst (e.g., a G3 or G4 palladacycle, 1-3 mol%), the phosphine ligand (e.g., RuPhos, 1.5-4.5 mol%), and sodium tert-butoxide (1.4 mmol).
- **Reagent Addition:** Add **2-chloro-5-isopropoxy pyridine** (1.0 mmol) and aniline (1.2 mmol).
- **Solvent Addition:** Add dry, degassed toluene or 1,4-dioxane (5 mL).
- **Reaction:** Seal the tube and heat the mixture to 80-110 °C.
- **Monitoring:** Monitor the reaction by LC-MS until the starting material is consumed.
- **Work-up & Purification:** Cool the reaction mixture, dilute with ethyl acetate, and filter through a pad of celite to remove palladium residues. Wash the filtrate with water, dry the organic layer, and concentrate. Purify the product by column chromatography.

Reaction Type	Key Reagents	Typical Conditions	Primary Outcome
SNAr	Amine, Alkoxide	Base (K ₂ CO ₃), DMSO, 100-120 °C	C-N, C-O bond formation
Suzuki-Miyaura	Boronic Acid	Pd catalyst, Ligand, Base, Dioxane/H ₂ O, 100 °C	C-C bond formation
Buchwald-Hartwig	Amine	Pd catalyst, Ligand, NaOtBu, Toluene, 80- 110 °C	C-N bond formation

Table 1: Summary of Key Transformations and Typical Conditions.

Conclusion

The reactivity of **2-chloro-5-isopropoxy pyridine** is a textbook example of how substituent effects can be harnessed for strategic chemical synthesis. While the electron-deficient nature of the pyridine ring renders it largely inert to classical electrophilic substitution, this same property, in concert with the C2-chloro group, unlocks a rich and predictable chemistry based on nucleophilic substitution and palladium-catalyzed cross-coupling. The C2 position is the molecule's primary reactive center, readily undergoing displacement by a wide variety of nucleophiles and participating efficiently in robust C-C and C-N bond-forming reactions. This predictable, site-selective reactivity makes **2-chloro-5-isopropoxy pyridine** an invaluable and reliable building block for the construction of complex, high-value molecules in pharmaceutical and materials science.

Need Custom Synthesis?

BenchChem offers custom synthesis for rare earth carbides and specific isotopic labeling.

Email: info@benchchem.com or [Request Quote Online](#).

References

- 1. chemistry.stackexchange.com [chemistry.stackexchange.com]
- 2. m.youtube.com [m.youtube.com]
- 3. m.youtube.com [m.youtube.com]
- 4. youtube.com [youtube.com]
- 5. chemistry.stackexchange.com [chemistry.stackexchange.com]
- 6. masterorganicchemistry.com [masterorganicchemistry.com]
- 7. Nucleophilic aromatic substitution - Wikipedia [en.wikipedia.org]
- 8. Concerted Nucleophilic Aromatic Substitution Reactions - PMC [pubmed.ncbi.nlm.nih.gov]
- 9. researchgate.net [researchgate.net]
- 10. Cross-Coupling Reactions | NROChemistry [nrochemistry.com]
- 11. taylorandfrancis.com [taylorandfrancis.com]
- 12. researchgate.net [researchgate.net]
- 13. A General and Efficient Method for the Suzuki-Miyaura Coupling of 2-Pyridyl Nucleophiles - PMC [pubmed.ncbi.nlm.nih.gov]
- 14. Thieme E-Journals - Synlett / Abstract [thieme-connect.com]
- 15. pubs.acs.org [pubs.acs.org]
- 16. benchchem.com [benchchem.com]
- 17. Buchwald-Hartwig Cross Coupling Reaction [organic-chemistry.org]
- 18. Buchwald–Hartwig amination - Wikipedia [en.wikipedia.org]
- 19. benchchem.com [benchchem.com]
- To cite this document: BenchChem. [A Technical Guide to the Reactivity Profile of 2-Chloro-5-isopropoxy pyridine]. BenchChem, [2026]. [Online PDF]. Available at: [<https://www.benchchem.com/product/b1512368#reactivity-profile-of-the-pyridine-ring-in-2-chloro-5-isopropoxy-pyridine>]

Disclaimer & Data Validity:

The information provided in this document is for Research Use Only (RUO) and is strictly not intended for diagnostic or therapeutic procedures. While BenchChem strives to provide accurate protocols, we make no warranties, express or implied, regarding the fitness of this product for every specific experimental setup.

Technical Support: The protocols provided are for reference purposes. Unsure if this reagent suits your experiment? [[Contact our Ph.D. Support Team for a compatibility check](#)]

Need Industrial/Bulk Grade? [Request Custom Synthesis Quote](#)

BenchChem

Our mission is to be the trusted global source of essential and advanced chemicals, empowering scientists and researchers to drive progress in science and industry.

Contact

Address: 3281 E Guasti Rd
Ontario, CA 91761, United States
Phone: (601) 213-4426
Email: info@benchchem.com