

The Hopping Mechanism: Understanding Hole Transport in Amorphous Films

Author: BenchChem Technical Support Team. **Date:** May 2026

Compound of Interest

Compound Name: *N*-(4-Bromophenyl)-9,9-dimethyl-9H-fluoren-2-amine
CAS No.: 1644059-09-5
Cat. No.: B1511235

[Get Quote](#)

Unlike in crystalline inorganic semiconductors where charges move through delocalized bands, charge transport in amorphous organic films, such as those made from fluorenylamine derivatives, occurs via a thermally activated hopping mechanism. Holes are localized on individual molecules and "hop" between adjacent molecules under the influence of an applied electric field.

The efficiency of this process, and thus the macroscopic hole mobility (μ_h), is primarily governed by two factors:

- **Intermolecular Electronic Coupling:** The degree of orbital overlap between neighboring molecules. Stronger coupling facilitates faster hopping. This is highly sensitive to the distance and relative orientation of the molecules, which is influenced by molecular packing in the solid state.
- **Energetic Disorder (Positional and Orientational):** In an amorphous film, molecules are randomly oriented, leading to a distribution of energy levels for the highest occupied molecular orbitals (HOMOs), which are involved in hole transport. This creates a Gaussian

density of states (DOS). A larger width (σ) of this DOS signifies greater energetic disorder, which acts as a trap for charge carriers and reduces mobility.

Comparative Analysis of Key Fluorenylamine Derivatives

The foundational structure of these materials often involves a fluorene core, which provides rigidity and thermal stability, linked to triarylamine moieties, which are the primary sites for hole localization and transport. Subtle modifications to this core structure can lead to significant changes in hole mobility.

Let's compare three prominent derivatives:

- N,N'-Bis(3-methylphenyl)-N,N'-diphenylbenzidine (TPD): While not a fluorenylamine itself, TPD is a classic hole transport material and serves as a crucial benchmark. Its relatively low glass transition temperature (T_g) of $\sim 60^\circ\text{C}$ limits its thermal stability.
- N,N'-Diphenyl-N,N'-bis(9,9-dimethylfluoren-2-yl)benzidine (DMFL-TPD): This derivative incorporates the bulky and rigid 9,9-dimethylfluorene unit. This structural modification sterically hinders crystallization and significantly raises the glass transition temperature to 155°C , enhancing morphological stability.
- Bis[4-(N,N-diethylamino)phenyl]-9,9-dimethylfluorene (DMFL-APF): This molecule features a more compact structure with the fluorene core directly functionalized with arylamine groups.

Below is a summary of their hole mobility, measured using the Time-of-Flight (TOF) technique.

Derivative	Structure	Hole Mobility (μh) at $E \approx 0.6$ MV/cm	Glass Transition Temp. (T_g)	Source
TPD	$\sim 3\text{-}7 \times 10^{-4}$ cm^2/Vs	$\sim 60^\circ\text{C}$		
DMFL-TPD	$\sim 8 \times 10^{-4}$ cm^2/Vs	155°C		
DMFL-APF	$\sim 1 \times 10^{-2}$ cm^2/Vs	110°C		

Analysis of Structure-Property Relationships:

- From TPD to DMFL-TPD: The introduction of the 9,9-dimethylfluorene units in DMFL-TPD enhances the molecule's rigidity and steric bulk compared to TPD. This leads to a significantly higher glass transition temperature, which is crucial for preventing morphological changes and degradation in OLED devices during operation. The hole mobility is comparable to or slightly higher than that of TPD, suggesting that the fundamental triphenylamine (TPA) core responsible for transport remains effective, while the overall molecular stability is vastly improved.
- The High Mobility of DMFL-APF: DMFL-APF exhibits a hole mobility that is over an order of magnitude higher than both TPD and DMFL-TPD. This significant enhancement can be attributed to its more compact molecular structure. The shorter distance between the charge-carrying arylamine moieties likely leads to stronger intermolecular electronic coupling, facilitating more efficient hopping. This demonstrates a key principle in material design: minimizing the non-active structural components to increase the density of hopping sites can dramatically boost charge mobility.

Experimental Protocols for Hole Mobility

Measurement

Accurate measurement of hole mobility is paramount for evaluating and comparing hole transport materials. The Time-of-Flight (TOF) method is a direct and reliable technique for this purpose.

Time-of-Flight (TOF) Methodology

The TOF technique measures the time it takes for a sheet of photogenerated charge carriers to drift across a sample of known thickness under an applied electric field.

Causality Behind the Protocol: The core principle is to create a well-defined "packet" of charge carriers near one electrode and time their transit to the opposite electrode. A pulsed laser with a photon energy greater than the material's bandgap is used to generate electron-hole pairs in a thin region near a semi-transparent top electrode. By applying a positive bias to this electrode, the holes are driven across the bulk of the organic film, while the electrons are

extracted. The arrival of the hole packet at the counter-electrode is detected as a transient photocurrent.

Step-by-Step Experimental Protocol:

- Device Fabrication:
 - Begin with a pre-cleaned Indium Tin Oxide (ITO) coated glass substrate, which will serve as the anode.
 - Deposit a thick film (typically 5-10 μm) of the fluorenylamine derivative onto the ITO substrate. Thermal evaporation under high vacuum ($<10^{-6}$ Torr) is the preferred method to ensure high purity and uniform thickness. The thickness must be precisely measured using a profilometer.
 - Deposit a semi-transparent top electrode (e.g., a thin layer of Aluminum, ~ 30 nm) via thermal evaporation. This electrode must be thin enough to allow the laser pulse to penetrate but thick enough to establish a uniform electric field.
- Experimental Setup:
 - Mount the fabricated device in a cryostat with electrical feedthroughs and an optical window.
 - Connect the ITO anode to the positive terminal of a voltage source and the Al cathode to ground through a series load resistor (RL).
 - The voltage drop across the resistor is monitored by a fast digital oscilloscope to measure the transient photocurrent.
- Measurement Procedure:
 - Apply a stable DC voltage (V) across the device.
 - Direct a short laser pulse (e.g., from a nitrogen laser, $\lambda=337$ nm, pulse width < 5 ns) onto the semi-transparent Al electrode.

- The oscilloscope will trigger on the laser pulse and record the resulting photocurrent transient.
- The ideal transient photocurrent plot on a linear scale shows an initial spike, followed by a plateau, and then a drop-off as the charge packet reaches the counter-electrode.
- Data Analysis:
 - The transit time (t_T) is determined from the photocurrent transient. On a double logarithmic plot of photocurrent vs. time, t_T is identified as the "knee" or intersection point of the two slopes representing the plateau and the tail.
 - The hole mobility (μ_h) is then calculated using the formula: $\mu_h = d / (E * t_T) = d^2 / (V * t_T)$ where:
 - d is the thickness of the organic film.
 - V is the applied voltage.
 - E is the electric field ($E = V/d$).
 - t_T is the transit time.
 - Measurements should be repeated at various applied electric fields to check for field dependence, which is characteristic of hopping transport in disordered systems.

Visualization of the TOF Experimental Workflow:

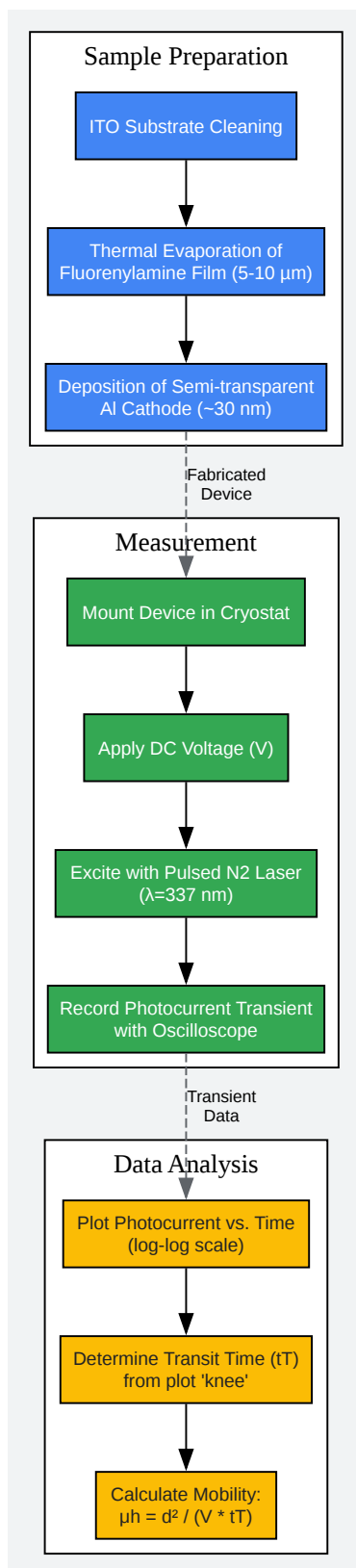

[Click to download full resolution via product page](#)

Caption: Workflow for hole mobility measurement using the Time-of-Flight (TOF) method.

Conclusion and Outlook

The hole mobility of fluorenylamine derivatives is intrinsically linked to their molecular structure. While the incorporation of rigid fluorene units, as in DMFL-TPD, is highly effective for enhancing thermal and morphological stability over benchmarks like TPD, optimizing for the highest mobility requires a focus on compact structures that promote strong intermolecular electronic coupling, as exemplified by the superior performance of DMFL-APF.

The Time-of-Flight methodology remains the gold standard for unambiguously determining charge carrier mobility in these materials. A rigorous and carefully executed experimental protocol is essential for obtaining reliable and reproducible data that can guide the rational design of next-generation hole transport materials for advanced organic electronic devices. Future research will likely focus on derivatives that not only possess high mobility but also exhibit deep HOMO levels for better energy level alignment with anodes and perovskite layers, further pushing the efficiency frontiers of OLEDs and solar cells.

References

- Thelakkat, M., & Schmidt, H. W. (1999). A new class of hole-transporting materials with a high glass-transition temperature. *Advanced Materials*, 11(5), 373-377. [[Link](#)]
- Schein, L. B., Rosenberg, A., & Rice, S. L. (1986). Hole transport in TPD/polycarbonate. *Journal of Applied Physics*, 60(12), 4287-4290. [[Link](#)]
- To cite this document: BenchChem. [The Hopping Mechanism: Understanding Hole Transport in Amorphous Films]. BenchChem, [2026]. [Online PDF]. Available at: [<https://www.benchchem.com/product/b1511235/docs#the-hopping-mechanism-understanding-hole-transport-in-amorphous-films>]

Disclaimer & Data Validity:

The information provided in this document is for Research Use Only (RUO) and is strictly not intended for diagnostic or therapeutic procedures. While BenchChem strives to provide accurate protocols, we make no warranties, express or implied, regarding the fitness of this product for every specific experimental setup.

Technical Support: The protocols provided are for reference purposes. Unsure if this reagent suits your experiment?

Need Industrial/Bulk Grade? [Request Custom Synthesis Quote](#)

BenchChem

Our mission is to be the trusted global source of essential and advanced chemicals, empowering scientists and researchers to drive progress in science and industry.

Contact

Address: 3281 E Guasti Rd
Ontario, CA 91761, United States
Phone: (601) 213-4426
Email: info@benchchem.com

[Contact our Ph.D. Support Team for a compatibility check](#)