

# Technical Support Center: Thymulin (FTS) ELISA Troubleshooting

**Author:** BenchChem Technical Support Team. **Date:** May 2026

## Compound of Interest

Compound Name: *Thymic factor, circulating*

CAS No.: 78922-62-0

Cat. No.: B1511138

[Get Quote](#)

## Executive Summary

Detecting Circulating Thymic Factor (FTS), or Thymulin, is notoriously difficult due to its small size (nonapeptide), rapid proteolytic degradation, and strict zinc dependence for conformational stability. Unlike robust protein analytes (e.g., Albumin), Thymulin requires a "biochemistry-first" approach to troubleshooting.

This guide bypasses generic ELISA advice to focus on the specific failure modes of metalloprotein immunoassays.

## Part 1: The "Silent" Failures (Pre-Analytical)

Q1: My standard curve looks perfect, but I cannot detect Thymulin in my human serum samples. Is the kit defective?

A: Likely not. If the standard curve is linear (

), the assay chemistry is working. The issue is almost certainly Pre-Analytical Sample Handling. Thymulin is not a stable protein; it is a labile metalloprotein.

### Root Cause Analysis:

- The "Zinc Trap" (Critical): Thymulin (FTS) is biologically active only when bound to Zinc ( ) in a 1:1 ratio. This binding induces the specific conformation recognized by most high-specificity antibodies.
  - The Error: Using EDTA plasma tubes. EDTA is a potent chelator ( ) that strips Zinc from FTS, causing the peptide to unfold and become undetectable to conformation-specific antibodies.
  - The Fix: Use Serum (red top, no additive) or Heparinized Plasma. Avoid EDTA or Citrate.
- Proteolytic Degradation: FTS is a small peptide (Glu-Ala-Lys-Ser-Gln-Gly-Gly-Ser-Asn) with a serum half-life of <10 minutes in vivo and highly unstable ex vivo due to serum proteases.
  - The Fix: Samples must be kept on ice immediately after draw. Centrifuge at . Add a protease inhibitor cocktail (specifically DPPIV inhibitors) if storage >1 hour is expected. Freeze at immediately.[1]
- The "Age Gap": Thymulin levels are age-dependent.[2][3][4]
  - Observation: High levels in children (birth to puberty).
  - Reality: Levels drop precipitously after 20-30 years of age. In donors >50 years, active Thymulin is often below the Limit of Detection (LOD) of standard ELISAs (<1 pg/mL).
  - Action: Verify donor age. Do not expect robust signals in adult/elderly control groups without concentration.

Q2: I see high variability between samples collected from the same subject. Why?

A: You are likely ignoring the Circadian Rhythm. Thymulin secretion is pulsatile and follows a circadian pattern, regulated by melatonin.[5] Levels peak during the dark phase (night/early morning) and reach a nadir during the day.

- Protocol Requirement: Standardize collection time (e.g., 08:00 – 09:00 AM). Random sampling times will yield uninterpretable noise.

## Part 2: Analytical Optimization & Protocol

Q3: I have high background in my serum samples but not in the standards. Is this a matrix effect?

A: Yes. Small peptides in complex matrices (serum) suffer from "masking" by high-abundance proteins like Albumin and Globulins.

The "Extraction" Decision:

- Direct ELISA: Most kits claim to work with direct serum. This often fails for low-abundance peptides due to steric hindrance.
- Extraction (Recommended): If you consistently see matrix interference (non-linearity of dilution), you must perform a C18 Solid Phase Extraction (SPE).

Protocol: C18 Peptide Extraction (For High-Sensitivity Applications)

- Acidify: Mix 1 mL Serum with 1 mL 1% Trifluoroacetic acid (TFA). Centrifuge 10,000 x g for 20 min to precipitate large proteins.
- Load: Pass supernatant through a pre-equilibrated C18 column (Sep-Pak).
- Wash: Wash with 10 mL 0.1% TFA (removes salts/unbound proteins).
- Elute: Elute FTS with 3 mL 60% Acetonitrile + 0.1% TFA.
- Dry: Evaporate eluate (SpeedVac) to dryness.
- Reconstitute: Resuspend in Assay Buffer to original volume.

Q4: My results are "Out of Range" (Low). What is the expected normal range?

Note: Ranges vary by kit sensitivity, but physiological expectations are:

Group	Expected Active Thymulin Range	Interpretation
Newborns/Children	2.0 – 5.0 pg/mL (High)	Active Thymopoiesis
Young Adults (20-30y)	0.5 – 1.5 pg/mL	Declining function
Adults (>50y)	< 0.2 pg/mL (Often Undetectable)	Thymic involution
Zinc Deficient	Undetectable	False negative due to unfolding

## Part 3: Visualizing the Failure Modes

Figure 1: The Zinc-Conformation Switch

This diagram illustrates why EDTA tubes cause false negatives. The antibody (Y-shape) requires the specific geometry created by the Zinc ion.

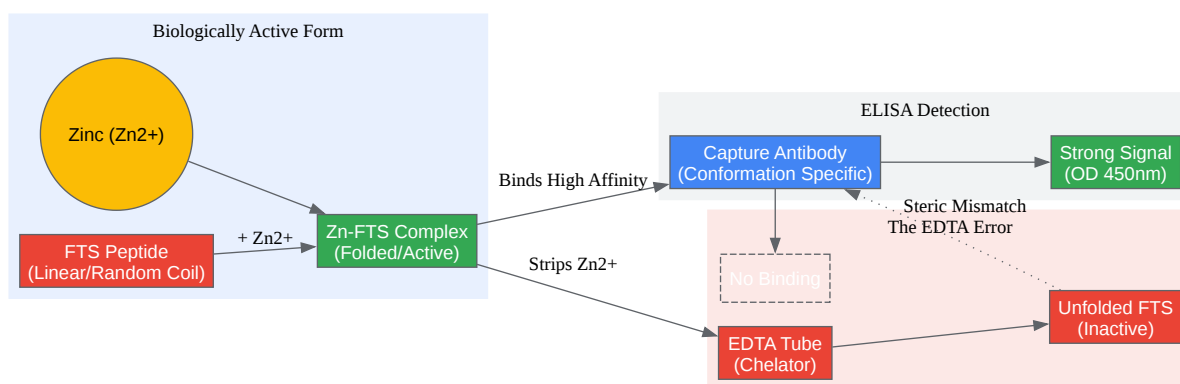

[Click to download full resolution via product page](#)

Caption: The "Zinc Switch": Thymulin detection relies on the Zn-induced conformational epitope. EDTA chelation reverts the peptide to a random coil, preventing antibody binding.

## Figure 2: Troubleshooting Logic Tree

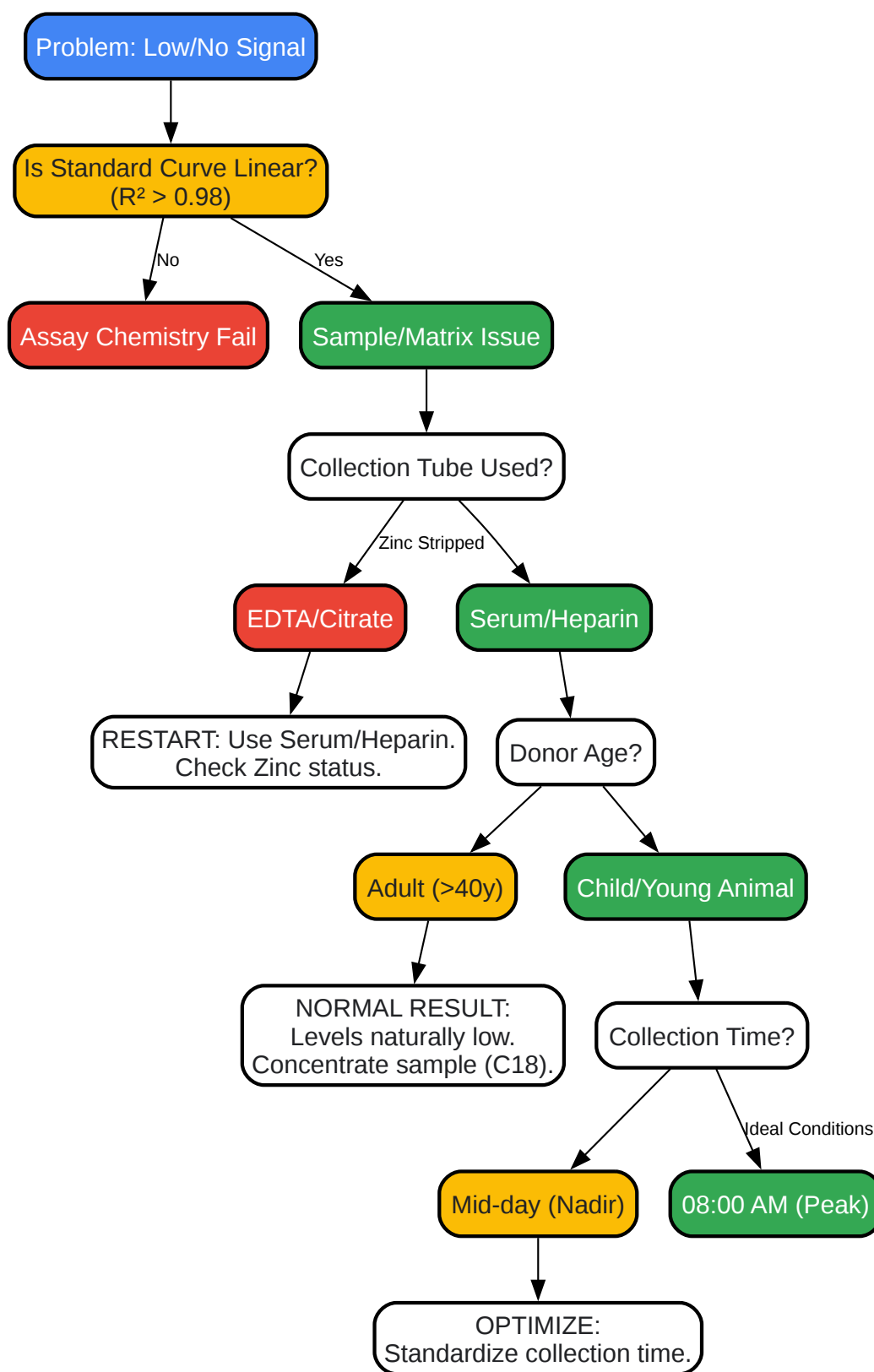

[Click to download full resolution via product page](#)

Caption: Step-by-step logic flow to isolate pre-analytical variables (Tube type, Age, Circadian Rhythm) before suspecting kit failure.

## Part 4: References & Authority

- Bach JF, Dardenne M. Thymulin, a zinc-dependent hormone.[2] *Med Oncol Tumor Pharmacother.* 1989. (Defining the Zinc-dependence of the peptide).
- Consolini R, et al. Distribution of age-related thymulin titres in normal subjects through the course of life.[4] *Clin Exp Immunol.* 2000.[4] [Link](#) (Establishing the age-related decline).
- Molinero P, et al. Melatonin is responsible for the nocturnal increase observed in serum and thymus of thymosin alpha1 and thymulin concentrations.[5] *Neurosci Lett.* 2000. [Link](#) (Establishing circadian rhythm).
- Immundiagnostik AG. Thymulin ELISA Kit Manual. (Standard commercial protocol reference for extraction methods).

### Need Custom Synthesis?

BenchChem offers custom synthesis for rare earth carbides and specific isotopic labeling.

Email: [info@benchchem.com](mailto:info@benchchem.com) or [Request Quote Online](#).

## Sources

- 1. [ELISA Sample Preparation Protocol - FineTest ELISA Kit | FineTest Antibody | FineTest® \[fn-test.com\]](#)
- 2. [Distribution of age-related thymulin titres in normal subjects through the course of life - PMC \[pmc.ncbi.nlm.nih.gov\]](#)
- 3. [Physiology and therapeutic potential of the thymic peptide thymulin - Rapamycin Longevity News \[rapamycin.news\]](#)
- 4. [Distribution of age-related thymulin titres in normal subjects through the course of life - PubMed \[pubmed.ncbi.nlm.nih.gov\]](#)
- 5. [Melatonin is responsible for the nocturnal increase observed in serum and thymus of thymosin alpha1 and thymulin concentrations: observations in rats and humans - PubMed \[pubmed.ncbi.nlm.nih.gov\]](#)

- To cite this document: BenchChem. [Technical Support Center: Thymulin (FTS) ELISA Troubleshooting]. BenchChem, [2026]. [Online PDF]. Available at: [<https://www.benchchem.com/product/b1511138/docs#technical-support-center-thymulin-fts-elisa-troubleshooting>]

---

### Disclaimer & Data Validity:

The information provided in this document is for Research Use Only (RUO) and is strictly not intended for diagnostic or therapeutic procedures. While BenchChem strives to provide accurate protocols, we make no warranties, express or implied, regarding the fitness of this product for every specific experimental setup.

**Technical Support:** The protocols provided are for reference purposes. Unsure if this reagent suits your experiment?

**Need Industrial/Bulk Grade?** [Request Custom Synthesis Quote](#)

## BenchChem

Our mission is to be the trusted global source of essential and advanced chemicals, empowering scientists and researchers to drive progress in science and industry.

### Contact

Address: 3281 E Guasti Rd  
Ontario, CA 91761, United States  
Phone: (601) 213-4426  
Email: [info@benchchem.com](mailto:info@benchchem.com)

[Contact our Ph.D. Support Team for a compatibility check](#)