

Introduction: Contextualizing 4-(2-Methoxyphenyl)oxazole

Author: BenchChem Technical Support Team. **Date:** May 2026

Compound of Interest

Compound Name: 4-(2-Methoxyphenyl)oxazole

CAS No.: 1126636-29-0

Cat. No.: B1511566

[Get Quote](#)

In the landscape of modern drug discovery and development, oxazole derivatives represent a cornerstone of heterocyclic chemistry, prized for their diverse pharmacological activities.[1] The compound **4-(2-Methoxyphenyl)oxazole**, a member of this vital class, presents a unique analytical challenge due to its specific isomeric structure. Its characterization is paramount, from ensuring purity in synthesis batches to identifying metabolites in pharmacokinetic studies. [2][3] Mass spectrometry (MS), particularly when coupled with liquid chromatography (LC), stands as the definitive technology for this purpose, offering unparalleled sensitivity and specificity.[4][5]

This guide provides a comprehensive framework for the mass spectrometric analysis of **4-(2-Methoxyphenyl)oxazole**. Moving beyond rote protocols, we will explore the causal reasoning behind methodological choices, from ionization strategies to fragmentation pathways, empowering researchers to develop robust and reliable analytical systems.

Chapter 1: Foundational Physicochemical Properties

A successful mass spectrometry analysis begins with a fundamental understanding of the analyte's properties. **4-(2-Methoxyphenyl)oxazole** is a small organic molecule whose structure dictates its behavior in the mass spectrometer.

Property	Value	Source
Molecular Formula	C ₁₀ H ₉ NO ₂	Calculated
Average Mass	175.18 g/mol	PubChem[6]
Monoisotopic Mass	175.06333 Da	PubChem[6]
Exact Mass of [M+H] ⁺	176.07115 Da	Calculated
Key Structural Features	Oxazole Ring, Phenyl Ring, Methoxy Group	-

Note: Data is for the isomeric 2-(4-Methoxyphenyl)oxazole from PubChem but the formula and masses are identical for **4-(2-Methoxyphenyl)oxazole**.

Chapter 2: The Strategic Choice of Ionization

The transition of an analyte from the liquid or solid phase to a gaseous ion is the critical first step in MS analysis. The choice of ionization technique is governed by the analyte's polarity, thermal stability, and molecular weight. For a moderately polar, non-volatile small molecule like **4-(2-Methoxyphenyl)oxazole**, Electrospray Ionization (ESI) is the superior method for LC-MS applications.[7][8]

Why Electrospray Ionization (ESI)?

ESI is a "soft" ionization technique that imparts minimal excess energy to the analyte, thereby preserving the intact molecule.[7] This is crucial as it predominantly generates the protonated molecular ion, [M+H]⁺, which serves as the precursor for subsequent structural analysis via tandem mass spectrometry (MS/MS). The process involves creating a fine spray of charged droplets from the liquid sample. As the solvent evaporates, the charge density on the droplet surface increases until ions are ejected into the gas phase.[7][9]

In contrast, a "hard" technique like Electron Ionization (EI), commonly used in GC-MS, bombards the molecule with high-energy electrons.[10][11] This causes extensive and often

uncontrollable fragmentation, which can lead to a weak or absent molecular ion peak, complicating the identification of an unknown compound.[12] While useful for creating fingerprint-like spectra for library matching of volatile compounds, it is less suitable for the nuanced structural elucidation required in drug development.[13]

Chapter 3: Elucidating Structure Through Tandem Mass Spectrometry (MS/MS)

Tandem mass spectrometry is an indispensable tool for confirming molecular structure by analyzing the fragmentation patterns of a selected precursor ion.[14][15] In an MS/MS experiment, the $[M+H]^+$ ion of **4-(2-Methoxyphenyl)oxazole** (m/z 176.07) is isolated in the first mass analyzer (MS1), subjected to fragmentation in a collision cell, and the resulting product ions are analyzed in the second mass analyzer (MS2).[15]

Proposed Fragmentation Pathway

The fragmentation of **4-(2-Methoxyphenyl)oxazole** is directed by its key functional groups: the oxazole ring, the ether linkage, and the aromatic system. The most common fragmentation patterns for phenyl-substituted oxazoles involve ring cleavage and rearrangements.[16][17] The methoxy group provides an additional, predictable fragmentation site.

Based on established chemical principles, the following primary fragmentation pathways are proposed:

- Loss of a Methyl Radical ($\bullet\text{CH}_3$): A characteristic fragmentation of the methoxy group, leading to a stable cation.
- Loss of Carbon Monoxide (CO): A common cleavage pathway for the oxazole ring.[17]
- Cleavage of the Phenyl-Oxazole Bond: Resulting in the formation of the methoxyphenyl cation.
- Combined Losses: Sequential fragmentation events, such as the loss of CO followed by HCN, can provide further structural confirmation.

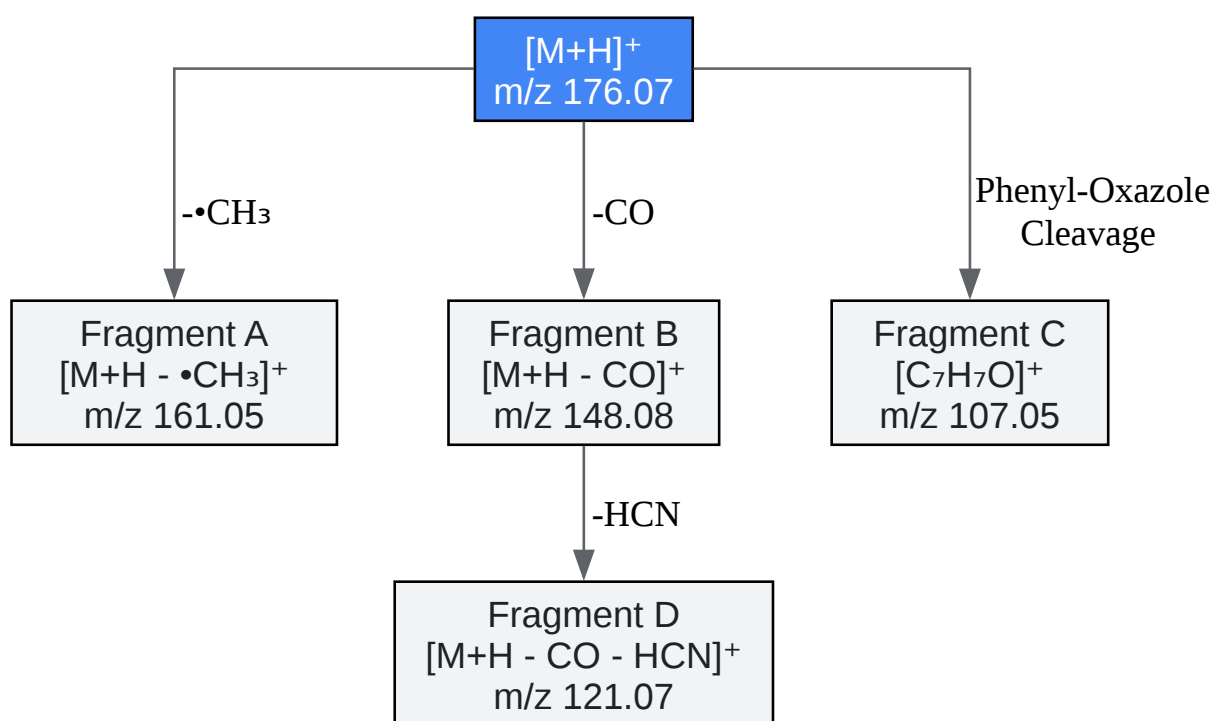

[Click to download full resolution via product page](#)

Caption: Proposed MS/MS fragmentation pathway for protonated **4-(2-Methoxyphenyl)oxazole**.

Chapter 4: A Validated Workflow for Analysis

A robust analytical method requires a systematic workflow, from sample preparation to data acquisition. The following protocol outlines a self-validating approach for the analysis of **4-(2-Methoxyphenyl)oxazole** using a standard LC-MS/MS system, such as a triple quadrupole instrument.^[4]

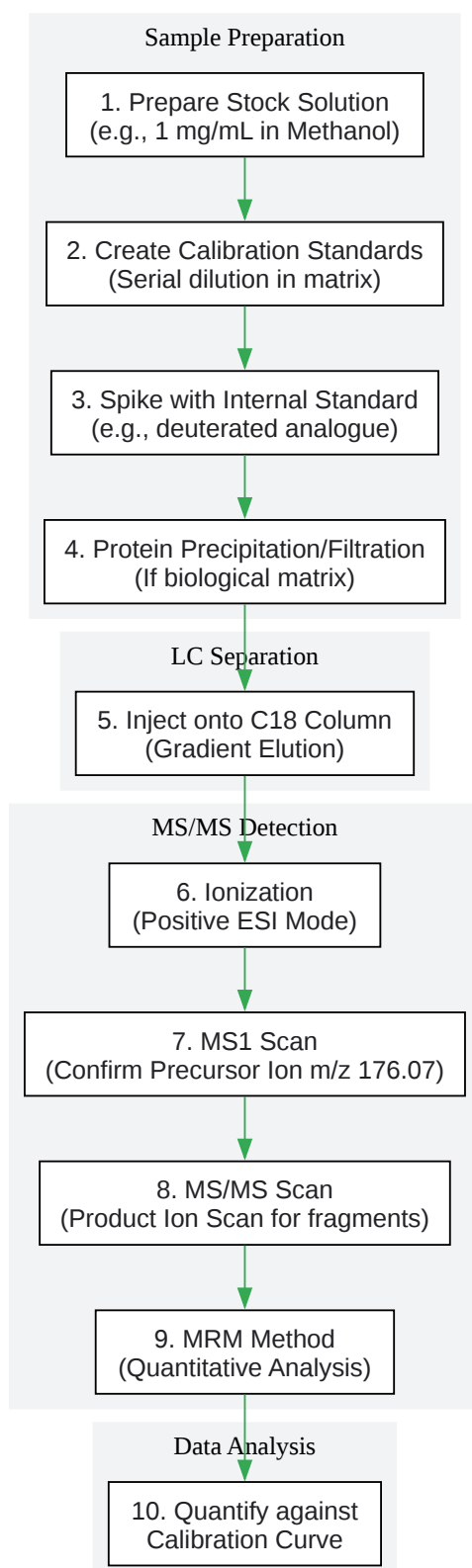

[Click to download full resolution via product page](#)

Caption: Standard LC-MS/MS workflow for the analysis of **4-(2-Methoxyphenyl)oxazole**.

Detailed Experimental Protocol

- Sample Preparation:
 - Prepare a 1 mg/mL stock solution of **4-(2-Methoxyphenyl)oxazole** in methanol.
 - Perform serial dilutions in the relevant matrix (e.g., plasma, buffer) to create calibration standards ranging from 1 ng/mL to 1000 ng/mL.
 - Spike all samples, standards, and quality controls with a stable isotope-labeled internal standard (e.g., d4-**4-(2-Methoxyphenyl)oxazole**) at a constant concentration. The use of an internal standard is critical for correcting variations in instrument response and sample preparation.^[18]
 - For biological samples, perform protein precipitation with acetonitrile, centrifuge, and filter the supernatant.
- Liquid Chromatography (LC) Conditions:
 - Column: C18 reverse-phase column (e.g., 2.1 x 50 mm, 1.8 μm).
 - Mobile Phase A: 0.1% Formic Acid in Water.
 - Mobile Phase B: 0.1% Formic Acid in Acetonitrile.
 - Gradient: Start at 10% B, ramp to 95% B over 5 minutes, hold for 2 minutes, and re-equilibrate.
 - Flow Rate: 0.4 mL/min.
 - Rationale: Reverse-phase chromatography effectively separates the moderately nonpolar analyte from polar matrix components. The acidic mobile phase promotes protonation, enhancing ionization efficiency in positive ESI mode.
- Mass Spectrometry (MS) Conditions:
 - Ionization Mode: ESI Positive.

- Capillary Voltage: 3.5 kV.
- Gas Temperature: 300 °C.
- Gas Flow: 8 L/min.
- Initial Scans: Perform a full scan (MS1) to confirm the presence of the precursor ion at m/z 176.07. Then, perform a product ion scan (MS/MS) on m/z 176.07 to identify the most abundant and stable fragment ions.

Chapter 5: Quantitative Analysis via Multiple Reaction Monitoring (MRM)

For accurate quantification in complex matrices, Multiple Reaction Monitoring (MRM) on a triple quadrupole mass spectrometer is the gold standard.^{[2][4]} This technique offers exceptional sensitivity and selectivity by monitoring specific precursor-to-product ion transitions.^[5]

Setting up the MRM Method

Based on the fragmentation data obtained in Chapter 3, at least two specific transitions should be selected for the analyte, plus one for the internal standard.

Compound	Precursor Ion (Q1) m/z	Product Ion (Q3) m/z	Role
4-(2-Methoxyphenyl)oxazole	176.07	161.05	Quantifier
4-(2-Methoxyphenyl)oxazole	176.07	148.08	Qualifier
Internal Standard (e.g., d4)	180.09	165.07	Reference

- Quantifier Ion: The most intense and stable fragment ion used for calculating the concentration.

- **Qualifier Ion:** A second fragment ion monitored to confirm the identity of the analyte. The ratio of the quantifier to the qualifier should be consistent across all samples and standards.
- **Method Validation:** A quantitative assay must be validated to demonstrate its accuracy, precision, linearity, and sensitivity, adhering to established guidelines.[5]

Conclusion

The mass spectrometric analysis of **4-(2-Methoxyphenyl)oxazole** is a multi-faceted process that relies on a sound understanding of the analyte's chemistry and the principles of mass spectrometry. By employing a soft ionization technique like ESI, elucidating the molecule's unique fragmentation signature through MS/MS, and developing a specific MRM method within a validated LC-MS/MS workflow, researchers can achieve highly reliable and accurate characterization and quantification. This guide provides the strategic framework and technical details necessary to empower scientists in drug development and related fields to confidently analyze this important class of molecules.

References

- Small Molecule Quantification by Liquid Chromatography-Mass Spectrometry for Metabolites of Drugs and Drug Candidates. (n.d.). NIH National Library of Medicine. Retrieved January 20, 2026, from [\[Link\]](#)
- Identifying Specific Small-Molecule Interactions Using Electrospray Ionization Mass Spectrometry. (2007). ACS Publications. Retrieved January 20, 2026, from [\[Link\]](#)
- Application of LCMS in small-molecule drug development. (2016). Drug Target Review. Retrieved January 20, 2026, from [\[Link\]](#)
- Electrospray Ionization (ESI) in LC-MS: Mechanism, Applications, and Future Innovations. (n.d.). TOFWERK. Retrieved January 20, 2026, from [\[Link\]](#)
- Refined Model for Ionization of Small Molecules in Electrospray Mass Spectrometry. (2019). Oxford Academic. Retrieved January 20, 2026, from [\[Link\]](#)
- From fundamentals in calibration to modern methodologies: A tutorial for small molecules quantification in liquid chromatography-mass spectrometry bioanalysis. (2023). PubMed.

Retrieved January 20, 2026, from [\[Link\]](#)

- Small and Large Molecule LC-MS. (n.d.). IQVIA. Retrieved January 20, 2026, from [\[Link\]](#)
- Modeling the relative response factor of small molecules in positive electrospray ionization. (2022). Royal Society of Chemistry. Retrieved January 20, 2026, from [\[Link\]](#)
- Quantifying Small Molecules by Mass Spectrometry. (2014). LCGC International. Retrieved January 20, 2026, from [\[Link\]](#)
- MASS SPECTROMETRY OF OXAZOLES. (n.d.). Semantic Scholar. Retrieved January 20, 2026, from [\[Link\]](#)
- Electron ionization. (n.d.). Wikipedia. Retrieved January 20, 2026, from [\[Link\]](#)
- Electrospray and APCI Mass Analysis. (n.d.). AxisPharm. Retrieved January 20, 2026, from [\[Link\]](#)
- 2-(4-Methoxyphenyl)oxazole. (n.d.). PubChem. Retrieved January 20, 2026, from [\[Link\]](#)
- Recent Advances in the Synthesis of Oxazole-Based Molecules via van Leusen Oxazole Synthesis. (2020). NIH National Library of Medicine. Retrieved January 20, 2026, from [\[Link\]](#)
- Tandem Mass Spectroscopy in Diagnosis and Clinical Research. (2015). NIH National Library of Medicine. Retrieved January 20, 2026, from [\[Link\]](#)
- Mass Spectrometry in Small Molecule Drug Development. (2015). American Pharmaceutical Review. Retrieved January 20, 2026, from [\[Link\]](#)
- Tandem mass spectrometry (MS/MS): a promising new analytical technique for specific component determination in complex mixtures. (1983). ACS Publications. Retrieved January 20, 2026, from [\[Link\]](#)
- Identification of small molecules using accurate mass MS/MS search. (2017). NIH National Library of Medicine. Retrieved January 20, 2026, from [\[Link\]](#)
- Electron Ionization in GC-MS: The Gold Standard for Volatile Compound Analysis. (n.d.). TOFWERK. Retrieved January 20, 2026, from [\[Link\]](#)

- Tandem mass spectrometry. (n.d.). Wikipedia. Retrieved January 20, 2026, from [[Link](#)]
- Recent Advances in the Synthesis of Oxazole-Based Molecules via van Leusen Oxazole Synthesis. (2020). MDPI. Retrieved January 20, 2026, from [[Link](#)]
- Mass spectrometry of 1,2,5-oxadiazole N-oxide derivatives: use of deuterated analogues in fragmentation pattern studies. (2004). SciELO. Retrieved January 20, 2026, from [[Link](#)]
- Electron Ionization for GC–MS. (2014). LCGC International. Retrieved January 20, 2026, from [[Link](#)]
- Mass Spectrometry: Aromatic Compound Fragmentation. (n.d.). JoVE. Retrieved January 20, 2026, from [[Link](#)]
- Ionization Methods in Organic Mass Spectrometry. (n.d.). University of California, Riverside. Retrieved January 20, 2026, from [[Link](#)]
- Oxazole, 4,5-dihydro-4,4-dimethyl-2-((4-methoxyphenyl)methyl)-. (n.d.). PubChem. Retrieved January 20, 2026, from [[Link](#)]
- Mass spectrometry of 1,2,5-oxadiazole N-oxide derivatives: use of deuterated analogues in fragmentation pattern studies. (2004). Semantic Scholar. Retrieved January 20, 2026, from [[Link](#)]
- (PDF) Mass spectrometry of 1,2,5-oxadiazole N-oxide derivatives. Use of deuterated analogues in fragmentation pattern studies. (2004). ResearchGate. Retrieved January 20, 2026, from [[Link](#)]
- Review on Chemistry of Oxazole derivatives: Current to Future Therapeutic Prospective. (2023). Taylor & Francis Online. Retrieved January 20, 2026, from [[Link](#)]
- Synthesis, crystal structure, and Hirschfeld surface analysis of novel ethyl 5-bromo-2-(4-methoxyphenyl) oxazole-4-carboxylate. (2023). Journal of Pharmaceutical Chemistry. Retrieved January 20, 2026, from [[Link](#)]
- Exploration of Compounds with 2-Phenylbenzo[d]oxazole Scaffold as Potential Skin-Lightening Agents through Inhibition of Melanin Biosynthesis and Tyrosinase Activity. (2022).

MDPI. Retrieved January 20, 2026, from [[Link](#)]

- Oxazole. (n.d.). Wikipedia. Retrieved January 20, 2026, from [[Link](#)]
- Oxazole, 4,5-dihydro-2-methyl-. (n.d.). NIST WebBook. Retrieved January 20, 2026, from [[Link](#)]
- Oxazole, 4,5-dihydro-4-(methoxymethyl)-2-methyl-5-phenyl-, (4s,5s)-. (n.d.). PubChemLite. Retrieved January 20, 2026, from [[Link](#)]

Need Custom Synthesis?

BenchChem offers custom synthesis for rare earth carbides and specific isotopic labeling.

Email: info@benchchem.com or [Request Quote Online](#).

Sources

- 1. tandfonline.com [tandfonline.com]
- 2. europeanpharmaceuticalreview.com [europeanpharmaceuticalreview.com]
- 3. americanpharmaceuticalreview.com [americanpharmaceuticalreview.com]
- 4. labs.iqvia.com [labs.iqvia.com]
- 5. chromatographyonline.com [chromatographyonline.com]
- 6. 2-(4-Methoxyphenyl)oxazole | C₁₀H₉NO₂ | CID 14931773 - PubChem [pubchem.ncbi.nlm.nih.gov]
- 7. Electrospray Ionization (ESI) in LC-MS: Mechanism, Applications, and Future Innovations - MetwareBio [metwarebio.com]
- 8. Electrospray and APCI Mass Analysis | AxisPharm [axispharm.com]
- 9. academic.oup.com [academic.oup.com]
- 10. Electron ionization - Wikipedia [en.wikipedia.org]
- 11. chromatographyonline.com [chromatographyonline.com]
- 12. as.uky.edu [as.uky.edu]
- 13. Electron Ionization in GC-MS: The Gold Standard for Volatile Compound Analysis - MetwareBio [metwarebio.com]

- [14. Tandem Mass Spectroscopy in Diagnosis and Clinical Research - PMC \[pmc.ncbi.nlm.nih.gov\]](#)
- [15. Tandem mass spectrometry - Wikipedia \[en.wikipedia.org\]](#)
- [16. pdf.benchchem.com \[pdf.benchchem.com\]](#)
- [17. pdfs.semanticscholar.org \[pdfs.semanticscholar.org\]](#)
- [18. Small Molecule Quantification by Liquid Chromatography-Mass Spectrometry for Metabolites of Drugs and Drug Candidates - PMC \[pmc.ncbi.nlm.nih.gov\]](#)
- To cite this document: BenchChem. [Introduction: Contextualizing 4-(2-Methoxyphenyl)oxazole]. BenchChem, [2026]. [Online PDF]. Available at: [\[https://www.benchchem.com/product/b1511566/docs#introduction-contextualizing-4-2-methoxyphenyl-oxazole\]](https://www.benchchem.com/product/b1511566/docs#introduction-contextualizing-4-2-methoxyphenyl-oxazole)

Disclaimer & Data Validity:

The information provided in this document is for Research Use Only (RUO) and is strictly not intended for diagnostic or therapeutic procedures. While BenchChem strives to provide accurate protocols, we make no warranties, express or implied, regarding the fitness of this product for every specific experimental setup.

Technical Support: The protocols provided are for reference purposes. Unsure if this reagent suits your experiment?

Need Industrial/Bulk Grade? [Request Custom Synthesis Quote](#)

BenchChem

Our mission is to be the trusted global source of essential and advanced chemicals, empowering scientists and researchers to drive progress in science and industry.

Contact

Address: 3281 E Guasti Rd
Ontario, CA 91761, United States
Phone: (601) 213-4426
Email: info@benchchem.com

Contact our Ph.D. Support Team for a compatibility check