

Mass Spectrometry Fragmentation Pattern of Fenamic Acid Derivatives: A Comparative Technical Guide

Author: BenchChem Technical Support Team. **Date:** May 2026

Compound of Interest

Compound Name:	2-((2-Methoxy-5-methylphenyl)amino)benzoic acid
CAS No.:	24542-66-3
Cat. No.:	B15101594

[Get Quote](#)

Executive Summary & Core Mechanism

Fenamic acid derivatives (e.g., Mefenamic, Tolfenamic, Flufenamic, Meclofenamic acid) share a core N-phenylanthranilic acid scaffold. Their mass spectrometric behavior is governed by the ortho-positioning of the carboxylic acid and the secondary amine.

The "Ortho Effect" Insight: In positive ionization modes (ESI+), the defining fragmentation event is not random bond cleavage but a structure-specific cyclization. The protonated molecular ion undergoes rapid dehydration (loss of 18 Da) to form a stable acridinium ion. This pathway is so dominant that it often suppresses other fragments, serving as a diagnostic fingerprint for the fenamate class.

In negative ionization modes (ESI-), the fragmentation is driven by the stability of the carboxylate anion, leading to a characteristic decarboxylation (loss of 44 Da,

).

Comparative Analysis of Ionization Techniques

Choosing the right ionization source is critical for sensitivity and structural information.

Feature	Electrospray Ionization (ESI)	Electron Ionization (EI)	Application Context
Energy Regime	Soft Ionization	Hard Ionization (70 eV)	ESI for quantitation; EI for library matching.
Dominant Ion	or	(often weak)	ESI preserves the molecular ion.
Fragmentation	Low in source; requires CID (MS/MS)	Extensive in source	EI provides structural fingerprints without MS/MS.
Key Fragment	(Acridinium)	(Acridone)	Both show water loss, but charge state differs.
Sensitivity	High (pg/mL range)	Moderate (ng/mL range)	ESI is superior for trace residue analysis in biological matrices.

Fragmentation Mechanisms (Mechanistic Deep Dive)

Positive Mode: The Acridinium Cyclization Pathway

The proximity of the secondary amine nitrogen to the carboxylic acid carbonyl carbon facilitates an intramolecular nucleophilic attack.

Mechanism:

- Protonation: The carbonyl oxygen or amine nitrogen accepts a proton.
- Cyclization: The amine nitrogen attacks the carbonyl carbon.

- Elimination: Water is expelled, closing the third ring to form the acridinium core.

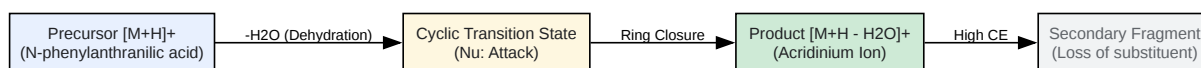

[Click to download full resolution via product page](#)

Figure 1: Mechanistic pathway of acridinium ion formation in positive ESI.

Negative Mode: Decarboxylation

In negative mode, the carboxylate group

is stable but prone to losing neutral carbon dioxide upon collisional activation.

Mechanism:

Characteristic Ions & Transitions (Data Tables)

The following table consolidates experimental MS/MS data for the major fenamic acid derivatives. These transitions are validated for Multiple Reaction Monitoring (MRM) workflows.

Table 1: Validated MS/MS Transitions

Compound	MW	Polarity	Precursor ()	Quantifier Product ()	Qualifier Product ()	Mechanism of Quantifier
Mefenamic Acid	241.29	ESI (+)	242	224	209	Dehydration (Acridinium)
ESI (-)	240	196	196	Decarboxylation ()		
Tolfenamic Acid	261.70	ESI (+)	262	244	216	Dehydration (Acridinium)
ESI (-)	260	216	180	Decarboxylation ()		
Flufenamic Acid	281.23	ESI (+)	282	264	244	Dehydration (Acridinium)
ESI (-)	280	236	216	Decarboxylation ()		
Meclofenamic Acid	296.15	ESI (+)	296	278	242	Dehydration (Acridinium)
ESI (-)	294	250	214	Decarboxylation ()		

)

Note: For chlorinated compounds (Meclofenamic, Tolfenamic), expect characteristic Chlorine isotope patterns (

ratio of ~3:1).

Experimental Protocol: LC-MS/MS Workflow

This protocol is optimized for the simultaneous quantification of multiple fenamates in biological matrices (plasma/urine).

Chromatographic Conditions

- Column: C18 or C8 Reverse Phase (e.g., 100 x 2.1 mm, 1.7 µm particle size).
- Mobile Phase A: Water + 0.1% Formic Acid (or 2mM Ammonium Formate for negative mode stability).
- Mobile Phase B: Acetonitrile + 0.1% Formic Acid.
- Flow Rate: 0.3 - 0.5 mL/min.
- Gradient:
 - 0-1 min: 10% B (Equilibration)
 - 1-6 min: 10% -> 90% B (Linear Ramp)
 - 6-8 min: 90% B (Wash)
 - 8.1 min: 10% B (Re-equilibration)

Mass Spectrometer Settings (Generic Triple Quad)

- Source: Electrospray Ionization (ESI)^{[1][2][3][4][5][6]}
- Spray Voltage: +4500 V (Pos) / -3500 V (Neg)

- Capillary Temp: 350°C
- Desolvation Gas: High flow (e.g., 50-60 psi) to aid droplet evaporation.
- Collision Energy (CE):
 - Dehydration transition (e.g., 242->224): Low to Medium CE (15-25 eV).
 - Secondary fragmentation (e.g., 224->209): Higher CE (30-40 eV).

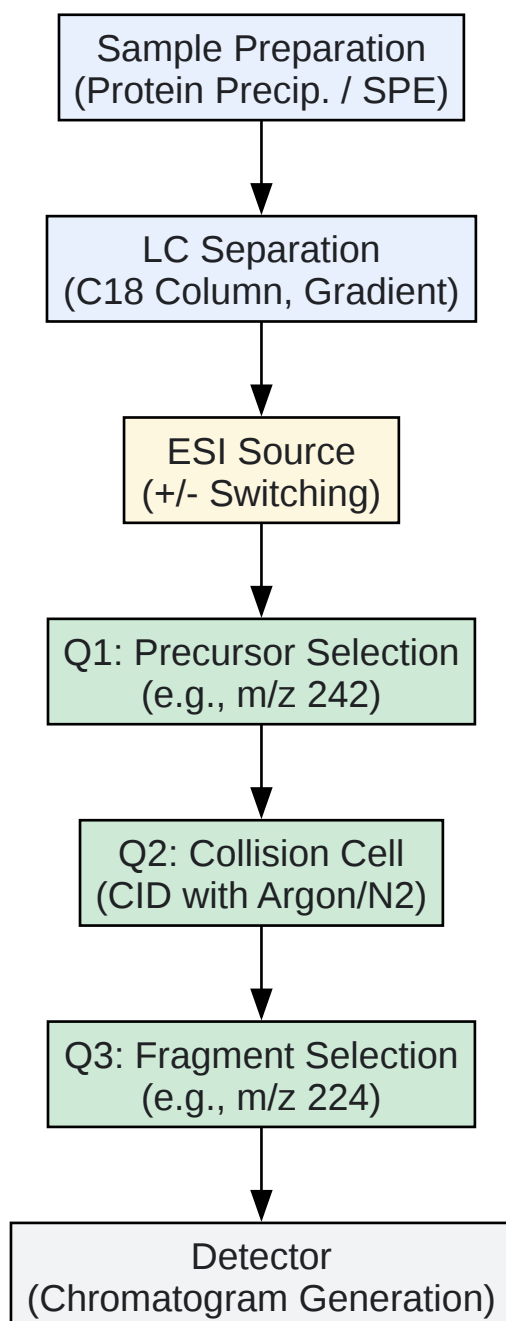

[Click to download full resolution via product page](#)

Figure 2: Standard Triple Quadrupole (QqQ) Workflow for Fenamate Analysis.

References

- Soft Ionization of Metallo-Mefenamic Using Electrospray Ionization Mass Spectrometry
Source: Korea Science
 - [\[Link\]](#)
 - Relevance: Confirms the $[M+H]^+$ (m/z 242) and $[M+H-H_2O]^+$ (m/z 224) transition for mefenamic acid and discusses metal adducts.
- LC-MS/MS Determination of 21 Non-Steroidal Anti-Inflammatory Drugs Residues in Animal Milk and Muscles Source: N
 - [\[Link\]](#)
 - Relevance: Provides validated transitions for Tolfenamic, Flufenamic, and Mefenamic acid in a multi-residue context.
- Multi-residue liquid chromatography/tandem mass spectrometry method for the detection of non-steroidal anti-inflammatory drugs in bovine muscle Source: ResearchG
 - [\[Link\]](#)
 - Relevance: Detailed MS3 data for Tolfenamic acid (m/z 260 \rightarrow 216 \rightarrow 180)
- High Throughput LC-MS/MS Method for the Quantitation of Mefenamic Acid in Rat Plasma
Source: Impact Factor / Journal of Applied Pharmaceutical Science
 - [\[Link\]](#)
 - Relevance: Provides specific protocol details for Mefenamic acid quantific

Need Custom Synthesis?

BenchChem offers custom synthesis for rare earth carbides and specific isotopic labeling.

Email: info@benchchem.com or [Request Quote Online](#).

Sources

- 1. Revisiting Fragmentation Reactions of Protonated α -Amino Acids by High-Resolution Electrospray Ionization Tandem Mass Spectrometry with Collision-Induced Dissociation - PMC [[pmc.ncbi.nlm.nih.gov](https://pubmed.ncbi.nlm.nih.gov/)]
- 2. [researchgate.net](https://www.researchgate.net/) [[researchgate.net](https://www.researchgate.net/)]
- 3. [newomics.com](https://www.newomics.com/) [[newomics.com](https://www.newomics.com/)]
- 4. [chromatographyonline.com](https://www.chromatographyonline.com/) [[chromatographyonline.com](https://www.chromatographyonline.com/)]
- 5. [mdpi.com](https://www.mdpi.com/) [[mdpi.com](https://www.mdpi.com/)]
- 6. [uab.edu](https://www.uab.edu/) [[uab.edu](https://www.uab.edu/)]
- To cite this document: BenchChem. [Mass Spectrometry Fragmentation Pattern of Fenamic Acid Derivatives: A Comparative Technical Guide]. BenchChem, [2026]. [Online PDF]. Available at: [<https://www.benchchem.com/product/b15101594/docs#mass-spectrometry-fragmentation-pattern-of-fenamic-acid-derivatives-a-comparative-technical-guide>]

Disclaimer & Data Validity:

The information provided in this document is for Research Use Only (RUO) and is strictly not intended for diagnostic or therapeutic procedures. While BenchChem strives to provide accurate protocols, we make no warranties, express or implied, regarding the fitness of this product for every specific experimental setup.

Technical Support: The protocols provided are for reference purposes. Unsure if this reagent suits your experiment?

Need Industrial/Bulk Grade? [Request Custom Synthesis Quote](#)

BenchChem

Our mission is to be the trusted global source of essential and advanced chemicals, empowering scientists and researchers to drive progress in science and industry.

Contact

Address: 3281 E Guasti Rd

Ontario, CA 91761, United States

Phone: (601) 213-4426

Email: info@benchchem.com

[Contact our Ph.D. Support Team for a compatibility check](#)